

Theory Book

COMPUTER  
APPLICATIONS  
TECHNOLOGY

10



basic education

Department:  
Basic Education  
REPUBLIC OF SOUTH AFRICA



## **MTN SOUTH AFRICA, THROUGH MTN SA FOUNDATION IS A PROUD SUPPORTER OF CAT AND IT DIGITAL BOOKS.**

As an organisation rooted in technology, we believe in providing a new bold digital world to communities we operate in. This unique digital book provides the fundamental knowledge necessary for a sound grounding from which to make practical use of the complete and indispensable application-oriented information regarding Computer Applications Technology (CAT) and Information Technology (IT). It is a foundational reference for today's secondary school learners and teachers alike – as well as for the next generation of CAT and IT students.

### **Computer Applications Technology Grade 10 Theory Book**

ISBN: 978-1-928388-60-9

First published in 2019 © 2019. Copyright in the text remains with the contributors.

#### **Restrictions**

You may not make copies of this book in part or in full – in printed or electronic or audio or video form – for a profit seeking purpose.

#### **Rights of other copyright holders**

All reasonable efforts have been made to ensure that materials included are not already copyrighted to other entities, or in a small number of cases, to seek permission from and acknowledge copyright holders. In some cases, this may not have been possible. The publishers welcome the opportunity to redress this with any unacknowledged copyright holders.

# Contents

## Term 1

<b>Chapter 1</b>	<b>Concepts of computing</b>	<b>1</b>
	Introduction	1
<b>Unit 1.1</b>	Information and communication technology	2
	ICT systems used in everyday life	2
	Activity 1.1	4
<b>Unit 1.2</b>	Data and information	5
	The GIGO principle	6
	The information-processing cycle	6
	Activity 1.2	7
<b>Unit 1.3</b>	Computers and ICT	9
	Activity 1.3	10
<b>Unit 1.4</b>	Types of computers	12
	Multi-purpose devices	12
	Dedicated (embedded) devices	14
<b>Unit 1.5</b>	Economic benefits of computers	15
	Activity 1.4	15
	Revision activity	17
	At the end of the chapter	18

## Term 2

<b>Chapter 2</b>	<b>Using a computer</b>	<b>19</b>
	Introduction	19
<b>Unit 2.1</b>	Operating a computer	20
	Switching the computer on	20
	Using the mouse	20
	Using the keyboard	21
	Using the desktop	22
	Activity 2.1	24
	Getting to know Windows	26
	File management	27
	Activity 2.2	28

<b>Unit 2.2</b>	Posture and ergonomics	29
	Social implications: Correct typing posture	29
	Ergonomics	30
	Prevention	31
	Activity 2.3	31
	Revision activity	32
	At the end of the chapter	33

## Chapter 3 File management 34

	Introduction	34
<b>Unit 3.1</b>	Basic concepts of file management	35
	Folders	36
	File path	37
	Activity 3.1	38
	Organising files and folders	39
	Using a file manager (This PC)	39
	Activity 3.2	46
<b>Unit 3.2</b>	File types	48
	Text files	48
	Document files	49
	Locked document files	50
	Web pages	50
	Archives and compressed files	50
	Presentation files	51
	Spreadsheet files	51
	Database files	52
	Image files	52
	Animation files	53
	Video files	53
	Sound files	54
	Portable document format (PDF)	54
	Activity 3.3	54
	Revision activity	55
	At the end of the chapter	56

<b>Chapter 4</b>	<b>File and print management</b>	<b>57</b>	<b>Unit 5.5</b>	Green computing	82
	<b>Introduction</b>	57		Going green when printing	82
<b>Unit 4.1</b>	File management skills	58		Activity 5.5	83
	Creating shortcuts	58	<b>Revision activity</b>		83
	Taking screenshots	60	<b>At the end of the chapter</b>		84
	Activity 4.1	61			
<b>Unit 4.2</b>	File compression	62	<b>Chapter 6</b>	<b>Extended hardware concepts</b>	<b>85</b>
	Compressing and decompressing files and folders	62		<b>Introduction</b>	85
	Activity 4.2	63	<b>Unit 6.1</b>	More about input devices	86
<b>Unit 4.3</b>	Print management	64		Pointing devices	86
	Adding a new peripheral	64		Digital camera	87
	Changing the default printer	65		Scanning and reading devices	87
	Basic printing	65		Video input devices	90
	Printer queue management	66		Audio input devices	91
	Activity 4.3	66		Biometric input devices	91
<b>Revision activity</b>		66		Activity 6.1	93
<b>At the end of the chapter</b>		67	<b>Unit 6.2</b>	More about output devices	94
				Audio output	94
				Other output	94
				Activity 6.2	95
<b>Chapter 5</b>	<b>Hardware</b>	<b>68</b>	<b>Unit 6.3</b>	Storage media and devices	96
	<b>Introduction</b>	68		Activity 6.3	96
<b>Unit 5.1</b>	What is hardware?	70	<b>Unit 6.4</b>	Processing devices	97
	Ports and connectors	70		Motherboard	97
	Adapters and converters	71		Central Processing Unit (CPU)	97
	Activity 5.1	71		Memory	98
<b>Unit 5.2</b>	Input devices	72		Activity 6.4	99
	Common input devices	72	<b>Unit 6.5</b>	Caring for your PC and storage devices	100
	Pointing devices	73	<b>Revision activity</b>		101
	Activity 5.2	74	<b>At the end of the chapter</b>		103
<b>Unit 5.3</b>	Output devices	75			
	Common output devices	75	<b>Chapter 7</b>	<b>Computer software</b>	<b>104</b>
	Activity 5.3	77		<b>Introduction</b>	104
<b>Unit 5.4</b>	Storage devices	78	<b>Unit 7.1</b>	Basic software concepts	105
	Concepts used in storage capacity	78		Application software	105
	Common storage devices	78		Accessories	106
	Capacity and robustness of storage devices	80		System software	109
	Connecting peripherals	80		Activity 7.1	109
	Activity 5.4	81	<b>Unit 7.2</b>	Operating system	110
				The role of the operating system	110
				The operating system and GUI	110

	Different operating systems	114
	Mobile operating systems	115
	Activity 7.2	116
<b>Unit 7.3</b>	Being more secure	117
	Create a password	117
	Other authentication methods	118
	Activity 7.3	118
	<b>Revision activity</b>	119
	<b>At the end of the chapter</b>	120
<b>Chapter 8</b>	<b>Extended software concepts</b>	<b>121</b>
	<b>Introduction</b>	121
<b>Unit 8.1</b>	Types of software	122
	Freeware, shareware and proprietary software	122
<b>Unit 8.2</b>	System software	124
	Drivers	124
<b>Unit 8.3</b>	Licensing and licensing agreements	127
	Software licensing and licence agreements	127
	Software piracy	127
	Activity 8.1	128
	<b>Revision activity</b>	128
	<b>At the end of the chapter</b>	129
<b>Chapter 9</b>	<b>Introduction to networks and networking concepts</b>	<b>130</b>
	<b>Introduction</b>	130
<b>Unit 9.1</b>	Concepts used in networks	131
	Activity 9.1	132
<b>Unit 9.2</b>	Uses of networks	133
	Aims and objectives of networks	133
	Advantages and disadvantages of networks	135
<b>Unit 9.3</b>	Social implications: Networks	137
	Viruses	137
	Licensing contracts	137
	User policies	138
	Ownership of electronic material	138
	Activity 9.2	138
	<b>Revision activity</b>	139
	<b>At the end of the chapter</b>	139

## Term 3

### Chapter 10 Types of networks: PAN/HAN 140

#### Introduction 140

#### Unit 10.1 PAN/HAN 141

Wired and wireless networks 141

HANs and PANs 142

#### Unit 10.2 Creating a PAN/HAN 145

Requirements 145

Connecting to the internet 147

Activity 10.1 148

#### Revision activity 149

#### At the end of the chapter 149

### Chapter 11 The internet and world wide web 150

#### Introduction 150

#### Unit 11.1 The internet 151

Internet address 151

#### Unit 11.2 The world wide web 153

Important concepts used with the world wide web 153

Using a web browser 153

What is the difference between a web page and a website? 155

URLs, URL shortener and the address bar 157

Links 158

Navigation buttons 161

Tabbed browsing 161

Activity 11.1 164

#### Unit 11.3 Search engines 165

Searching for information 165

Basic browsing and searching techniques 165

Refining your search 166

#### Unit 11.4 Downloads and uploads 169

Downloading 169

Uploading 171

Activity 11.2 172

#### Revision activity 172

#### At the end of the chapter 174

**Chapter 12** Internet communication \_\_\_\_\_ 175

Introduction \_\_\_\_\_ 175

**Unit 12.1** Electronic communication devices \_\_\_\_\_ 177  
E-communication using a PC or mobile device \_\_\_\_ 177  
Activity 12.1 \_\_\_\_\_ 180**Unit 12.2** Email as a form of e-communication \_\_\_\_\_ 181  
Components of an email address \_\_\_\_\_ 182  
ISP versus webmail \_\_\_\_\_ 183  
How email works \_\_\_\_\_ 184  
Activity 12.2 \_\_\_\_\_ 185**Unit 12.3** Basic emailing \_\_\_\_\_ 186  
Email interface \_\_\_\_\_ 186  
Sending emails \_\_\_\_\_ 188  
Replying to emails \_\_\_\_\_ 190  
Hyperlinks in emails \_\_\_\_\_ 192  
Etiquette in emails \_\_\_\_\_ 194  
Activity 12.3 \_\_\_\_\_ 196

Revision activity \_\_\_\_\_ 197

At the end of the chapter \_\_\_\_\_ 198

**Chapter 13** Social implications: Email and internet \_ 199

Introduction \_\_\_\_\_ 199

**Unit 13.1** Social implications: Email and internet safety \_\_\_\_ 200  
Computer crimes \_\_\_\_\_ 202  
Activity 13.1 \_\_\_\_\_ 203  
Safe internet and email use \_\_\_\_\_ 203  
Activity 13.2 \_\_\_\_\_ 204

Revision activity \_\_\_\_\_ 204

At the end of the chapter \_\_\_\_\_ 205

**Term 4****Chapter 14** Information management \_\_\_\_\_ 206

Introduction \_\_\_\_\_ 206

**Unit 14.1** Concepts used in information management \_\_\_\_ 207**Unit 14.2** Practical Assessment Task (PAT) overview \_\_\_\_ 209  
Techniques used in information management \_\_\_\_ 209  
Activity 14.1 \_\_\_\_\_ 214**Unit 14.3** Sifting data \_\_\_\_\_ 215  
Information versus knowledge \_\_\_\_\_ 215  
Sifting information \_\_\_\_\_ 215  
Activity 14.2 \_\_\_\_\_ 215**Unit 14.4** Processing data \_\_\_\_\_ 216  
Knowledge versus insight/decision making \_\_\_\_ 216  
The importance of information manipulation \_\_\_\_ 216  
Data handling using a spreadsheet \_\_\_\_\_ 217  
Processing data using a spreadsheet \_\_\_\_\_ 217**Unit 14.5** Presenting data \_\_\_\_\_ 219  
Graphs and tables \_\_\_\_\_ 219  
Reports \_\_\_\_\_ 220  
Slide show presentation \_\_\_\_\_ 222  
Finalising the PAT \_\_\_\_\_ 222  
Activity 14.3 \_\_\_\_\_ 222

Revision activity \_\_\_\_\_ 223

At the end of the chapter \_\_\_\_\_ 225

Glossary \_\_\_\_\_ 226

# CONCEPTS OF COMPUTING

## CHAPTER OVERVIEW



Unit 1.1	Information and communication technology
Unit 1.2	Data and information
Unit 1.3	Computers and ICT
Unit 1.4	Types of computers
Unit 1.5	Economic benefits of computers

At the end of this chapter, you should be able to:



- Understand ICT systems and how they are used in everyday life.
- Distinguish between data and information.
- Give examples of data and information used.
- Identify the main concepts of a computer.
- Understand the difference between hardware and software.
- Describe the information-processing cycle with reference to how it uses hardware devices in each stage.
- Describe the different types of computers and their uses.
- Explain the economic reasons for using computers.
- Understand the different social implications regarding the use of ICT.

## INTRODUCTION

We use many different types of computers, or computer-controlled devices every day. This can range from smartphones and calculators, to the scanners used in supermarkets.

The history of computing goes back over 2 500 years to the abacus, which is a simple calculator made from beads and wires, and is still used in some parts of the world today.

In the following units, you will learn more about the different concepts used in computing, the different types of **ICT** systems used, as well as what the difference is between data and information. You will also look at the various components of a computer and the different types of computers available. Lastly, you will learn about the economic value of computers.

## 1.1 Information and communication technology

### ICT SYSTEMS USED IN EVERYDAY LIFE

ICT systems are often confused with computers; however, they are not the same thing. Computers refer to the hardware that forms part of an ICT system. The ICT system refers to the overall set-up, consisting of hardware, **software**, data and the people that use it. It commonly includes communication technology, such as the internet.

Information and communication technology (ICT) is a field that is related to computers and communication networks. It can also be in the form of audiovisuals, for example, film and digital productions. Digital technologies use data, such as text, numbers, images, sounds and videos. Computers use this data to show information.

In the past, these technologies used to be separate systems, but recently, these technologies have become almost “one”. Computers have become more like smartphones and smartphones have become more like computers. ICT is the field that looks at all these technologies as one.

An ICT system depends on computers, data and people to make the system work. For ICT systems to function correctly, they need to receive, store, retrieve, manipulate and transmit data. Data is often in the form of text, numbers, sounds and images.

#### EXAMPLE OF AN ICT SYSTEM IN EVERYDAY LIFE

Computers, however, cannot act on their own; a computer needs someone to give it (enter) the data that needs to be processed. To understand how it works, look at the following example.

Supermarkets and chain stores use ICT systems for a variety of reasons. In this example, we will look at the processes of receiving, manipulating, storing and communicating data at a point-of-sale (POS) system.

#### PROCESSES AT A POS SYSTEM

When you look at a supermarket’s ICT system from the cashier and customer’s point of view, all you see is a stand-alone computer. This computer is called a cash register. However, the cash register consists of much more than that.

All items have a **barcode**, which is a pattern of narrow and wide stripes that can be read by a barcode reader. The barcode reader is used to scan the barcode optically and convert the stripes into numerical data, which can automatically be transferred to the check-out computer (i.e. the cash register). The barcode reader sometimes beeps after scanning an item to signal to the cashier that the item has been identified.



**Figure 1.1:** An example of a barcode

### INPUT AND STORING DATA

When an item is scanned, the check-out computer checks for the price of the item in the database. The running total of each item is stored temporarily in the check-out terminal. (There may be other data stored there as well, such as money that was taken out of the till during the day.)

### MANIPULATING DATA

After all the items have been scanned, the check-out computer calculates the data to determine the total cost. If the customer pays with cash and requires change, the cashier will enter the amount given and the check-out computer will calculate any change that should be given to the customer. This is an example of the computer receiving data from the user.

### TRANSMITTING DATA

When all the items are scanned into the check-out computer, the customer can see information about the price of each item, which is shown on a small display.

After all the items have been scanned, the total amount is shown. The customer then pays and is given a printed till receipt showing all the items that were bought and how much each item costs.



**Figure 1.2:** *Cash register and receipt*

## COMMUNICATION

In some instances, a product's data can also be sent to the shop's main computer for stocktaking purposes, as well as to the manufacturer for their stock purposes.



### Activity 1.1

1. Explain the term ICT. Do not just expand on the acronym.
2. What does POS stand for?
3. The following table shows a few activities that take place before check-out. Match these activities with one of the following processes associated with a POS, as seen from the customer's point of view:
  - Receives
  - Sends
  - Stores
  - Retrieves
  - Manipulates

ACTIVITY	PROCESS
Scan a barcode	
Calculate change	
Provide a receipt	
<b>Total cost of items purchased</b>	

4. Imagine a world without ICT systems, or ICT-controlled devices. ICTs have several advantages and disadvantages. Copy and fill in the table below, and list three advantages and disadvantages of ICT systems.

ADVANTAGES	DISADVANTAGES

## 1.2 Data and information

In computing, it is very important to understand the difference between data and information. This section will look at the differences between the two and the importance thereof.

What do you think of first when you hear the word *data*? What comes to mind is raw material, which refers to something that has not yet been processed. Data needs to be processed before it can become useful. Data can be in the form of text, words, numbers or symbols which, if not put into some type of context, is pretty useless to us.

Information, on the other hand, is data that is processed and formatted in such a way that we can actually use it. Both data and information are important; it is through accurate data collection that people, such as managers, have the necessary information to make informed decisions. Let's take a look at the following examples of data and information:

Example of data	5605, David, 30, Bisho, 0731112222, Ramaphosa, Mahlangu, Avenue
Example of information	David Mahlangu 30 Ramaphosa Avenue Bisho 5605 (073) 111 2222

As you can see from this example, the data appears to be a set of random words and numbers. Only after the data has been interpreted, organised and formatted, you can see that it is the contact details for David Mahlangu.





Let's look at the following example of how data can be converted into useful information.

## DETERMINING HOW THE LEARNERS DO IN MATHEMATICS

Mandla's Mathematics teacher needs to determine how the learners in her class are performing. She must get the test results (data) and the average of each learner, as well as the average mark for the entire class (information).

There are five learners in the Mathematics class and so far, they have written three tests.

**Table 1.1:** Data about learners' test results for three tests

				
James	Mandla	Lucy	Jarred	Zanele
$\frac{13}{20} \frac{20}{30} \frac{7}{15}$	$\frac{14}{20} \frac{18}{30} \frac{11}{15}$	$\frac{10}{20} \frac{23}{30} \frac{9}{15}$	$\frac{13}{20} \frac{21}{30} \frac{8}{15}$	$\frac{18}{20} \frac{25}{30} \frac{8}{15}$

... continued



## Animation

Make an animation similar to what is shown in the following video:

<https://www.youtube.com/watch?v=Rs57-PQyqaE>

You can also use baking a cake as example. This example will include the following as data: flour, baking soda, salt, milk, eggs, icing sugar, the oven as the computer and the cake as information.

## DETERMINING HOW THE LEARNERS DO IN MATHEMATICS

**Table 1.2:** Maths results Term 1 (sorted from highest to lowest score in percentage)

	TEST 1	TEST 2	TEST 3	TOTAL	AVERAGE (%)
Learner	20	30	15	65	
Zanele	18	25	8	51	78
Mandla	14	18	11	43	66
Lucy	10	23	9	42	65
Jarred	13	21	8	42	65
James	13	20	7	40	62
TERM AVERAGE MARK					67

Tables 1.1 and 1.2 show the difference between data and information. In Table 1.1, we cannot see how the learners are performing. However, after the computer manipulated the test scores, we are given meaningful information, as can be seen in Table 1.2. Remember, the information we get out of a computer is only as good as the data that is entered into it.

## THE GIGO PRINCIPLE

GIGO is an acronym for *Garbage In, Garbage Out*. Simply put, it means that bad input will result in bad output. It is very important to remember the GIGO principle, because bad data will give you bad information.

Using the example of the learners' test results, if the teacher entered the incorrect marks into the computer (i.e. bad data), the information that she would get as a result, will also be incorrect.

It is quite possible for data to be interpreted incorrectly. This is often the result of incorrect or incomplete data, or a lack of context.

## THE INFORMATION-PROCESSING CYCLE

For you to understand how a computer works, you need to understand the information-processing cycle. The stages in this cycle repeat itself over and over again and is made up of the following:

- **Input:** In the first stage of computing, the computer receives some data or instructions to follow.
- **Processing:** In the second stage of computing, the computer follows the instructions programmed into it and manipulates the data in some way.
- **Output:** In the third stage of computing, the computer supplies the new, manipulated information in some way. This information can be displayed on the screen (for example, the message you see on the screen while you type), or it can be sent to a different part of the computer where it is received as input.
- **Storage:** An **optional** stage is where data is stored. The data can be stored permanently (on a **hard drive**), or temporarily (on RAM – i.e. the computer's short-term memory).

- **Communication:** Another optional stage is communication, where the output created is sent across a network to other computers. While this step used to be rare in the past, most computer programs perform some type of communication today.

An example of the information-processing cycle is shown in the following figure:

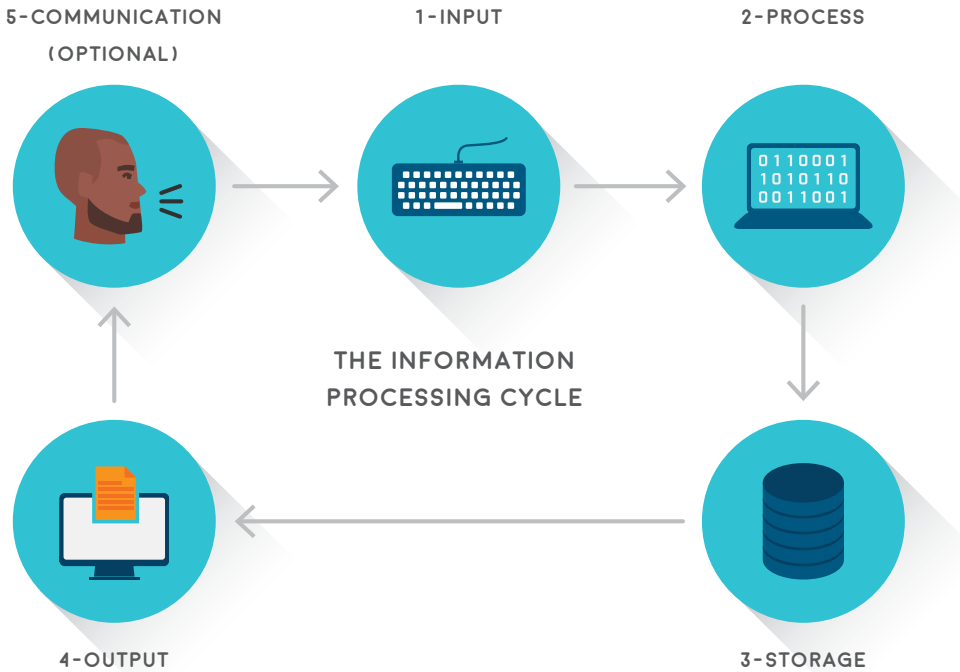

**Figure 1.3:** The information-processing cycle

The information-processing cycle is a series of stages carried out to get information from raw data. Although each of the first three stages explained above (input, processing and output) must be taken in order, the order is **cyclic**. The output stage can lead to the repeat of the data-collection stage, resulting in another cycle of data processing.

**Activity 1.2**

1. Sizwe is in Grade 10 and received his school report. When he looks at his report, this is what he sees:

SUBJECT	AVERAGE 73
Life Orientation Physical Science	80
Mathematics	67
Computer Applications Technology	65
Geography Business Studies	73 88 67

- 1.1 What is wrong with this report?
- 1.2 Which principle is referred to above?
- 1.3 Explain the difference between data and information.

... continued



## Activity 1.2

... continued

- 1.4 Use the data from the previous page and create a report showing the correct information for Sizwe. Use the table below to guide you:

SUBJECT	TERM MARK (%)
<b>Average</b>	

2. Answer the following questions based on the scenario below.

Computers are electronic devices that manipulate data and turn it into useful information. To see how this works, think about sending a WhatsApp message from a cell phone to a friend. The diagram below shows the different stages in sending a WhatsApp message.

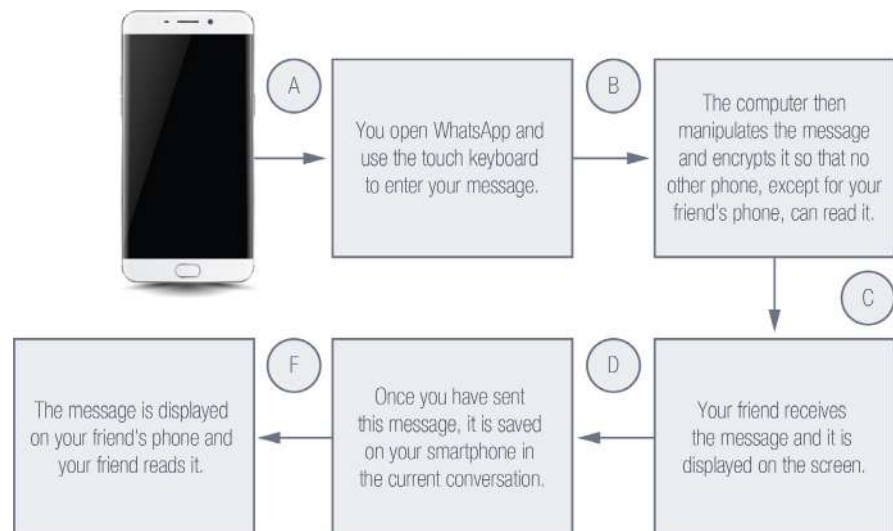

- 2.1 What process is shown in this diagram?  
 2.2 List the different stages from A to F.  
 2.3 What happens during Stage C of this cycle?  
 2.4 Indicate whether the following is input, output, or storage:
- Typing a message to a friend on WhatsApp
  - Music that you listen to from your phone
  - Printing a file
  - Playing videos using your phone
  - Photos that you keep on your phone

## 1.3 Computers and ICT

Computers are electronic devices that receive data, manipulate the data and then turn it into useful information, before storing it and/or sending it to someone, or somewhere, to be read or acted upon.

The following figure tries to explain how a computer works. You can see that the functions of a computer are similar to the stages of the information-processing cycle.

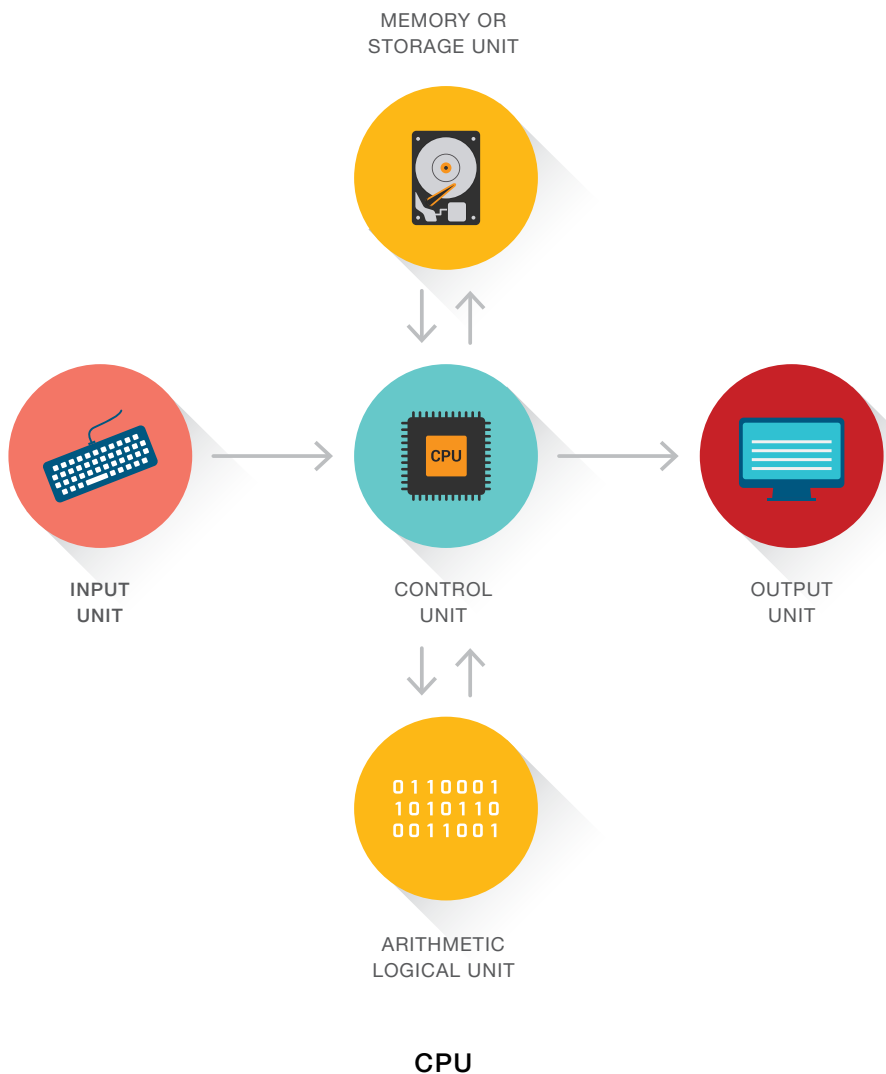

**Figure 1.4:** General model of a computer

Looking at the figure, you will see that all basic computers consist of four functions:

1. Input
2. Storage
3. Processing
4. Output

These four things are combined to make a computer work.

For a computer to function properly, it must consist of both hardware and software, which both depend on each other. Without software, the hardware of a computer will have no



WHAT MAKES A  
COMPUTER A  
COMPUTER?



<https://www.youtube.com/watch?v=mCq8-xTH7jA>

function and vice versa. Both of these concepts are discussed in detail in the chapters to follow; however, we will just briefly explain what each means.

- **Hardware:** The physical components of a computer, also referred to as the *equipment* of a computer.
- **Software:** More commonly known as apps (applications) or programs and consists of a list of instructions in a computer language that instructs the computer on what to do.

Examples of hardware devices consist of the following:

- Keyboard and mouse used for input
- Monitors, printers and speakers used for output
- Hard drives and flash disks used for storage
- Routers used for communication

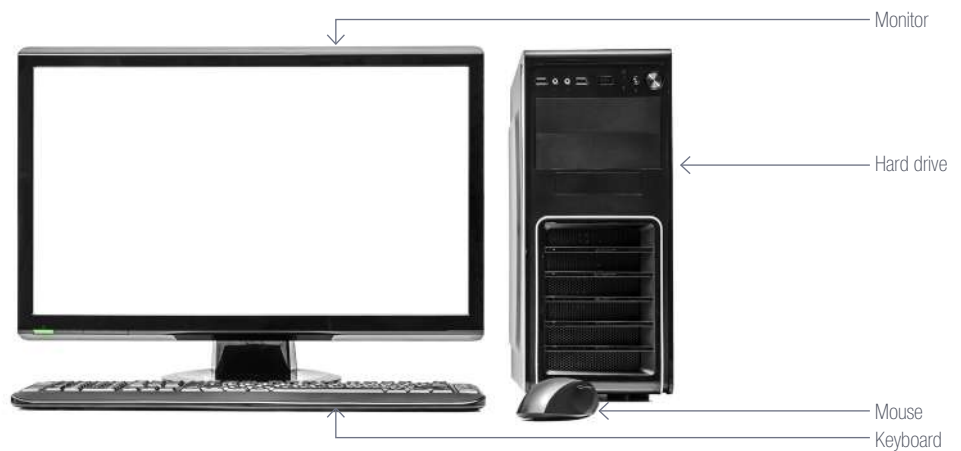

**Figure 1.5:** Computer hardware



### Activity 1.3

1. What is a computer?
2. Match each concept in Column A with the correct definition in Column B. Write only the number and the letter.

COLUMN A	COLUMN B
1. Hard disk	A. Can be text, numbers and figures that are used by computers
2. Data	B. Storage device
3. Input	C. Bad input will result in bad output
4. GIGO	D. The components that make up the computer
5. Output	E. The computer receives instructions to follow
6. Hardware	F. The information produced by a computer

... continued

3. Answer the questions based on the diagram below.

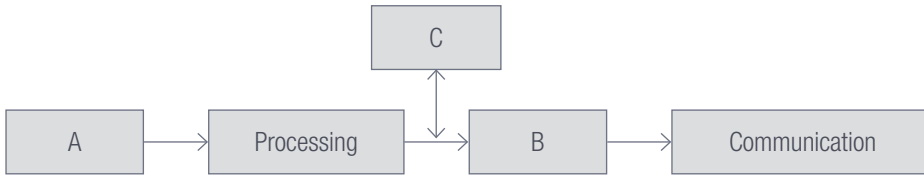

3.1 Name the missing stages, as indicated by the letters below:

- a. A:
- b. B:
- c. C:

3.2 List one example of each of the following:

- a. Hardware
- b. Software

3.3 Your teacher is busy printing out the term class reports. Which stage is this in the information-processing cycle?

4. Complete the following table and identify two hardware devices that your teacher will use for each of the missing stages. Motivate why she would use those specific devices.

STAGE	HARDWARE DEVICE	REASON
A		
B		
C		

# 1.4 Types of computers

As you know, computers are devices used to process information. There are several terms used to describe computers; most of these terms indicate the size and the capability of the computer. The two main categories of computers are:

1. **Multi-purpose:** These types of computers have an operating system that can run many applications at the same time. Some examples are devices, such as servers, laptops and smartphones.
2. **Dedicated devices:** These are devices that can only run one task. Some examples are ATMs and processors embedded in devices, such as refrigerators and motor cars.



**Figure 1.6:** Different types of computers

## MULTI-PURPOSE DEVICES



**Table 1.3:** Different types of general-purpose computers

DESCRIPTION	EXAMPLES OF WHERE THIS TECHNOLOGY IS USED
<p>Supercomputer</p>  <p>A supercomputer is the fastest, most powerful and most expensive type of computer made today. It is used to perform many instructions per minute.</p>	<p>Supercomputers are used for difficult or complicated calculations, such as:</p> <ul style="list-style-type: none"> <li>• Predicting the weather</li> <li>• Locating possible oil deposits</li> </ul>

... continued

DESCRIPTION	EXAMPLES OF WHERE THIS TECHNOLOGY IS USED
<p>Mainframe</p>  <p>A mainframe is a powerful computer that has a high processing power and performance. It is big in size and can be used by several people at the same time.</p>	<p>It is used primarily by large organisations for critical tasks, such as:</p> <ul style="list-style-type: none"> <li>• Bulk data processing and storing of vast amounts of data, for example, census</li> <li>• It is also used in banks, company head offices and IT organisations</li> </ul>
<p>Server</p>  <p>A server is a computer that has really powerful processors, large hard drives and plenty of memory power.</p>	<p>Servers are computers that provide (or serve) information to other computers (for example, <a href="#">web</a> pages). A server can be used in different environments, such as:</p> <ul style="list-style-type: none"> <li>• Offices and schools where data or a printer needs to be shared amongst many people</li> </ul>
<p>Workstation</p>  <p>A workstation is a type of computer with a high-resolution graphics screen and usually has a mass storage device, such as a <a href="#">disk drive</a>.</p>	<p>It is used to perform special tasks, such as:</p> <ul style="list-style-type: none"> <li>• Precision drawings</li> <li>• <b>Computer-aided design (CAD)</b>, 3D graphics and software development</li> <li>• It can also be used in different fields, such as engineering or medicine research</li> </ul>
<p>Desktop</p>  <p>A desktop computer is not designed to be carried around as it is made up of separate components. These computers are designed to be set up in a permanent location on a desk or table.</p>	<p>Desktops are used in a variety of environments, such as:</p> <ul style="list-style-type: none"> <li>• Schools: It helps school learners to gain knowledge by doing research for projects or assignments.</li> <li>• Entertainment: You can watch videos, listen to music, or stream videos.</li> <li>• Communication: Users can use desktops to make phone calls, send emails, and use instant messaging just by having a proper internet connection.</li> </ul>

... continued

DESCRIPTION	EXAMPLES OF WHERE THIS TECHNOLOGY IS USED
<p>Laptop</p>  <p>Laptops are also known as <i>notebooks</i> and are portable PCs that combine the display, keyboard, processor, memory, hard drive and <b>cursor-positioning device</b>, such as a touch- or trackpad, all in one package that is operated by a battery.</p>	<p>Laptops are best used for the office or at home. It can be used for basic administration tasks and daily office use. It can also be used for personal use, such as browsing the internet, listening to music, or watching videos.</p>
<p>Tablet</p>  <p>Tablets are smaller than normal laptops and are <b>ultra portable</b>. Although tablets are generally cheaper than brand-new laptops, their processors and other components are less powerful than regular laptops. Tablets have virtual keyboards, or make use of a <b>digital pen</b> instead of physical keyboards.</p>	<p>Tablets generally have one user. With this device, you can access information and data from anywhere in the world at any time. Tablets can be used in a variety of environments:</p> <ul style="list-style-type: none"> <li>• Home: Can be used for domestic use, such as listening to music, browsing the internet, listening to music and streaming videos.</li> <li>• Work: Can be used as a laptop replacement; however, you will need one that has at least a nine-inch screen.</li> <li>• School: Can be used to access study material, as well as browsing the internet, listening to music, or doing research for projects.</li> </ul>
<p>Smartphone</p>  <p>These handheld-sized computers use a <b>flash memory</b> instead of a hard drive for storage. It has virtual keyboards and uses <b>touch-screen</b> technology. Smartphones are lightweight and have a good battery life, depending on the make. You can access data and information as long as you have a good internet connection.</p>	<p>Smartphones are used in a variety of ways:</p> <ul style="list-style-type: none"> <li>• To <b>browse</b> the internet</li> <li>• To listen to music</li> <li>• To take photos</li> <li>• To navigate</li> <li>• To make phone calls and send and receive messages.</li> </ul>



## TYPES OF COMPUTERS



<https://www.youtube.com/watch?v=7q0F5ftDI8&list=PL0aNAKtW5HLRZAyE8XkucMuGZpKKCLi88&index=3>

## DEDICATED (EMBEDDED) DEVICES

**Embedded devices** are devices designed for a single purpose; whether that purpose is to wake you up in the morning, control the temperature of the air conditioning or help navigate. As such, these devices are usually excellent at their specific tasks, but they are also unable to do anything else. Embedded devices are designed to perform specific dedicated computing tasks. Examples of these devices are:

- ATM machines
- DVD players
- Anti-lock braking systems
- Digital watches
- MP3 players
- Drones
- Airbag control systems

## 1.5 Economic benefits of computers

Over the years, it became impossible to imagine a world without computers or computer-controlled devices, such as ATMs, cameras and music players.

Computers have several economic benefits, such as:

- **Saving paper:** Companies and individuals can save paper by working electronically on computers. People can now send letters (emails), magazines and read books electronically instead of having to print out hard copies. This also saves money and time in the long run. Estimates have shown that there can be a 10 to 30% decrease in paper usage if the correct technology is used.
- **Saving labour:** Businesses can save money and labour (people) by using computer-controlled devices to perform repetitive functions that require several employees to perform.
- **Communication speed and costs:** Telephone and postage costs can be decreased drastically using computers and the internet. It also allows information to be sent and received faster than in the past. For example, the use of email allows instant communication with staff, clients and other individuals at any place or time. The use of smartphones will help employers to keep in touch with their employees regularly, which ultimately saves time and phone calls.
- **Efficiency:** Instead of being swamped with paperwork or sorting out piles of paperwork, files can be stored on computers. Retrieval of old documents is much easier when it is stored electronically. Also, computers can do the work of more than one person in less time than normal employees.
- **Accuracy:** Computers produce more accurate data or results than human beings. This, however, depends on the quality of the input data. If the information entered is incorrect, the results produced will most likely be incorrect. Computers can, however, detect certain human errors and might highlight these errors.
- **Reliability:** Computers that are maintained properly will be reliable in the long run. It is safe to say that we can rely on computers to perform the tasks that they have been programmed to do.



### Activity 1.4

Read the following scenario and answer the questions that follow.

#### SAVING PAPER

The largest bank in the USA, Bank of America, greatly reduced its paper consumption by making use of electronic reports and forms, emails, double-sided copying and by using lighter-weight papers. As a result, it saved tonnes of paper, decreasing the consumption by 32%. (This is over a billion sheets of paper!)

- Give two examples of how computers benefit the economy by saving paper. Motivate your answer.
- List three ways of how computers have benefited the economy in South Africa. Motivate your answer.



## Case Study

### Thembisile and her smartphone

To understand how dependent we are becoming on smartphones, read the following case study about a day in Thembisile's life.

This is an example of a smartphone user, Thembisile, and how she uses her phone throughout the day.

Every morning at 07:00, Thembisile is woken up by the alarm on her smartphone. This alarm clock application has a function that plays soft music for five minutes before she has to wake up. This actually prepares her brain to wake up. After that, the tone becomes louder, which she cannot ignore. If she hits the snooze button, her alarm is set to snooze five times for five minutes at a time.

After Thembisile has woken up, she checks her emails, WhatsApp messages, other texts and her social media updates, such as Facebook and Twitter, which were set to not send any messages to her between 21:00 and 07:00.

She then has breakfast, which she logs into her *meal plan* application. This indicates the number of calories she consumed. She also adds toothpaste and soap to her *shopping list* application.

Her calendar application shows that she is supposed to be at the gym in 30 minutes. She gets into her car and mounts her phone on the hands-free device attached to the windscreen of her car. She then switches her phone to GPS navigation, which works out the best route to her three calendar appointments, i.e. gym, work and her 13:00 meeting.

At the gym, she uses her *gym application* and inputs her weight, height and energy level into the application. This gives her an exercise routine she should focus on for the session.

She realises she is running a little late for work, so she sends a quick message to her manager using an instant message service (IMS), such as WhatsApp. Her normal keyboard is replaced by **SwiftKey**, making it much quicker for her to type.

At work, Thembisile uses a *note-taking* application to make notes of the things she is currently working on, as well as the *scheduling* application, which books and shares new appointments. She then uses **CamCard** to scan the new business card she just received so that the details are automatically saved in her contact list.

Before going to bed, Thembisile quickly looks at the day's important news events on her *news* application and plays some of the several games on her phone, such as Pokémon, Candy Crush and Angry Birds.

At 22:00, her *sleep* application tells her it is time to sleep.

As you can see, Thembisile, and probably her entire family, are very active smartphone users. Information is transferred, stored and conveyed in their everyday lives. This is the direction that the world of technology is moving towards. It also shows us how dependent we are becoming on computers, or computer-operated devices.

Answer the following questions about the case study that you have just read:

1. Give a brief description of a smartphone.
2. Identify four applications that Thembisile uses during the day.
3. From the case study, identify five things for which Thembisile uses her phone. How does this improve her day-to-day life?
4. How does Thembisile's employer benefit from using a smartphone?
5. How does the SwiftKey keyboard differ from the normal keyboard on a smartphone?

## REVISION ACTIVITY

1. Study the picture of a computer below and answer the questions that follow:



- a. Identify and name two input devices. (2)
  - b. Is device A an input device or an output device? (1)
  - c. What is the function of device B? (2)
2. Match the user in Column A with the type of computer in Column B.

COLUMN A	COLUMN B
1. A weather scientist working for the South African Weather Services	A. Tablet
2. A sales representative who drives around visiting customers each day	B. Supercomputer
3. A school teacher preparing work at home	C. Server
	D. Desktop
	E. Laptop

3. Your school has bought a new computer for the administration office. List two economic benefits of having a computer in the office. Explain how the school benefits in each case. (6)
- a. Define what is meant by an embedded device. (2)
  - b. Give an example of an embedded device that will be found in a motor car. (1)

... continued

## REVISION ACTIVITY

... continued

5. Look at the diagram below and answer the questions that follow:

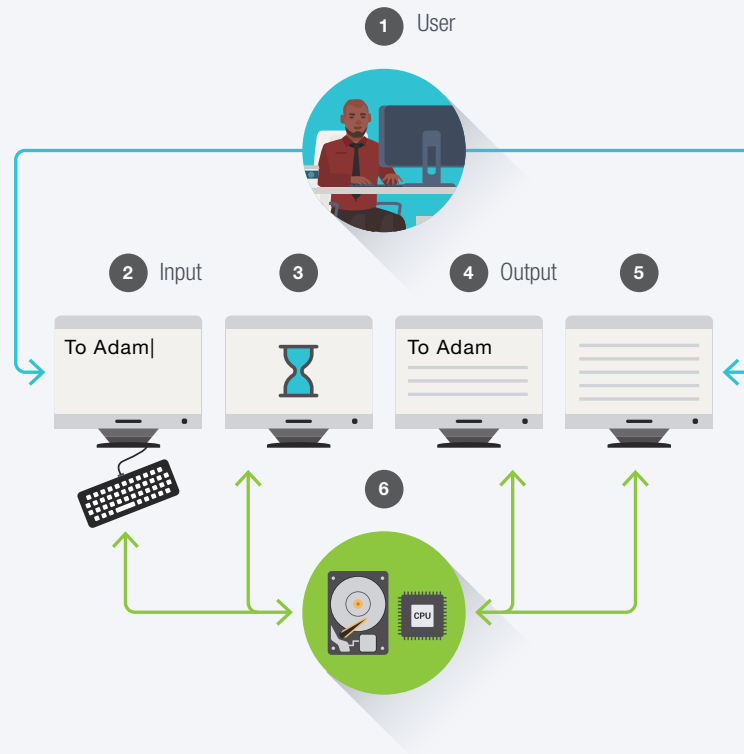

- a. What stage of the information-processing cycle is taking place at 3? (1)  
 b. Does stage 6 represent storage or communication? Give a reason for your answer. (2)
6. Your class teacher ticks off each morning who is present at school. At the end of the term, she determines how many times each learner in the class was absent. This number is included in the learner's term report. Using this scenario, explain the difference between data and information. (4)

**TOTAL: [24]**

## AT THE END OF THE CHAPTER

Use the checklist to make sure that you worked through the following and that you understand it.

NO.	DID YOU...	YES	NO
1.	Understand ICT systems and how they are used in everyday life.		
2.	Distinguish between data and information.		
3.	Give examples of data and information used.		
4.	Identify the main concepts of a computer.		
5.	Understand the difference between hardware and software.		
6.	Describe the information-processing cycle with reference to how it uses hardware devices in each stage.		
7.	Describe the different types of computers and their uses.		
8.	Understand the economic reasons for using computers.		

# USING A COMPUTER

## CHAPTER OVERVIEW



Unit 2.1 Operating a computer

Unit 2.2 Posture and ergonomics



At the end of this chapter, you should be able to:

- Switch a computer on.
- Use a mouse correctly.
- Identify and explain the different icons when using a mouse.
- Understand the different features of the desktop.
- Use your desktop.
- Explain the importance of the correct posture when working with a computer.

## INTRODUCTION

As a modern-day learner, you have probably used, seen, or read about computers. We use computers in our everyday lives, for example, in banks, schools, shops, hospitals, and maybe the people in your home use computers on a daily basis. Being able to use a computer is an important skill to learn; not only for school or university purposes, but also for the workplace.

In this chapter, we will introduce you to the practical side of using computers.

## 2.1 Operating a computer

Operating a computer may not be as difficult as you think. In this unit, we will focus on:

- Switching a computer on.
- Using the mouse correctly.
- Using your desktop.
- Applying basic file operations, such as opening, saving and printing a file.

### SWITCHING THE COMPUTER ON



#### Guided Activity 2.1

To start up your computer, you need to do the following:

1. Make sure that the computer has been plugged into a power socket.
2. To switch the computer on, press the *Power* button. On some computers, this button lights up after the computer is switched on.
3. The computer will now **boot**. This is when the computer loads the operating system and checks that all the components are in good order.
4. After the computer has booted, a **log on** screen might appear. Logging on allows registered users access to the computer. If you are the only user of the computer, it will go straight to the desktop screen once it is turned on.
5. If you share the computer with other users, you might have to log in your details. You can do this by typing in your **username** and **password**, and then pressing the *Enter* key. After the computer accepts the login details, the desktop display will appear on the screen.

### USING THE MOUSE

The mouse is one of the main hardware devices used to control the computer and interact with the GUI interface. Most mice are designed to have a scroller and two buttons – i.e. a left button and a right button, as seen in Figure 2.1.

When holding the mouse, rest your hand over it and place your index finger on the left button of the mouse. You can rest your thumb and pinkie (little finger) on the sides of the mouse. An example of how to do this is shown in Figure 2.2.



**Figure 2.1:** Mouse

**Figure 2.2:** How to hold a mouse

By **default**, a mouse is set for a right-handed person with the primary button on the left. You can change the function of the mouse buttons from the default left click to a right click.

However, most left-handed people either use the mouse in their right hand, or they place the mouse on the left-hand side of the keyboard and use their middle finger for the left button.

#### Something to know

Note that login procedures may differ with different systems.

#### Something to know



A computer uses your username and password to verify your identity. This prevents unauthorised access to your computer and the information on the computer. It also protects you from anyone trying to invade your privacy, or trying to delete or copy your information.

#### Something to know

Remember to make sure that the mouse is on a flat surface with the buttons pointing forward.

To explain how the mouse works, we will be using the left button of the mouse. The following table shows the basic things you need to know about a mouse.

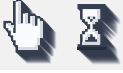
**Table 2.1:** *Basics of the mouse*

ACTION	IMAGE
When moving the mouse, you will see that you are moving a pointer or cursor on the screen.	
Depending on what you are doing, the shape of the cursor will change.	
With the hand icon, you can open a link on the internet.	
This icon shows that you must wait while the computer is doing a task.	

A mouse can do a variety of tasks, such as:

- **Selecting an item:** To select something, move the cursor over the item, click once with the left button and then you can let go.
- **Opening an item:** To open something like a file, double click the left button. This is usually how it works, but sometimes a single click will also open a program. Through practice, you will learn when to use which one.
- **Moving items:** To move an item, you must drag and drop. You do this by pressing down on the left button above the item, as you drag the mouse along. Once you have placed the item where you want it, you can let go of the left button.
- **Scrolling up and down a page:** This is done by rolling the scroll- or mouse wheel up or down.

## USING THE KEYBOARD

A keyboard is used for entering information, such as letters, words, numbers and symbols into a computer. Pressing any key on the keyboard is an input that the computer uses as data.

The basic keyboard, as seen in Figure 2.3, is called the QWERTY keyboard.

A keyboard is used for entering information, such as letters, words, numbers and symbols. Pressing any key on the keyboard is an input that the computer uses as data.



**Figure 2.3:** *QWERTY keyboard*

## USING THE DESKTOP

The desktop screen is the first thing you see when you switch the computer on. It has a logical display surface and contains user-interface objects, such as windows, menus and buttons. Its main features are the start button, **taskbar** and icons. For you to use the desktop, each computer has an operating system (OS). An operating system is the system software that allows a user to communicate with a computer in the following ways:

- It manages a computer's hardware, such as the input and output devices, network devices, as well as storage devices.
- It provides services to facilitate the operation and management of additional software application programs.
- It assigns the necessary memory.
- It provides the **graphical user interface (GUI)**, pronounced as "goeey", which allows a user to interact with and control software applications, or hardware devices using **graphical interface elements**, such as **windows**, **icons** and **menus**. This means that a program has graphical controls that a user can select using a mouse or keyboard.

The operating system has the following user interfaces:

- **Desktop:** This is the main screen of the GUI and consists of a system of icons on a screen.
- **Window:** Used to display the contents of an application with which the user can view and interact. It shows the information of each file, application, or folder in a separate window on the screen.
- **Dialogue boxes/message windows:** These are small or basic windows that are usually opened by a program to indicate to the user that more information is required.
- **Toolbars:** These are a set of icons at the top of a window, which can be clicked to perform certain functions.
- **List box:** This allows the user to selected one or more items from a list. The user must click the box next to the item to select it.
- **Checkbox:** This is a small square box on the screen, which allows the user to click it to indicate an answer, or to allow a setting.
- **Windows Explorer:** Windows Explorer is a GUI component available in Microsoft Windows that enables users to access, edit, copy, delete and manage data, files and other content stored on a computer, or mobile device.

Figure 2.4 is an example of an operating system interface.

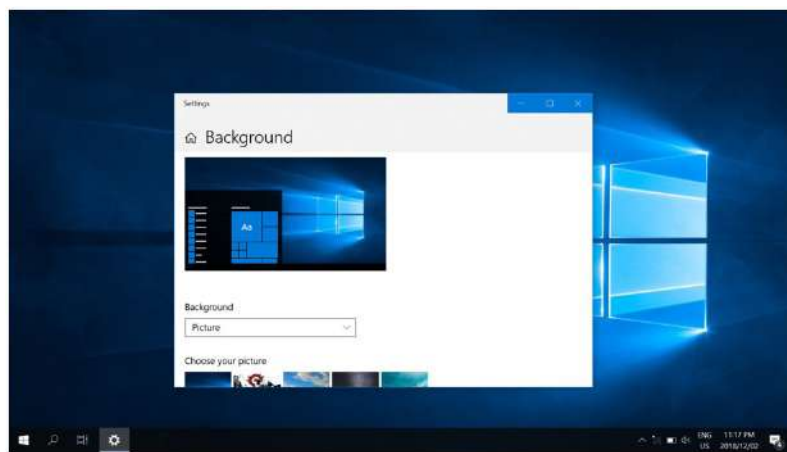

**Figure 2.4:** Example of an operating system interface

### Something to know

Whenever you are working on, or interacting with a computer, you are called the *user*. And the way in which the computer interacts with you, is called an *interface*.

### Something to know

With the new versions of Microsoft Windows, *Windows Explorer* is the default file manager, while *Finder* is the default file manager on Apple computers.

Figure 2.5 shows examples of some of the interfaces of an operating system:

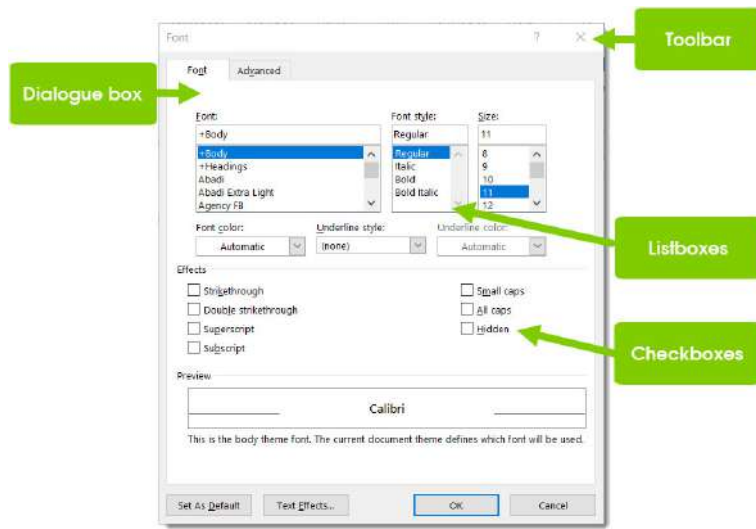

**Figure 2.5:** Different interfaces of an operating system

As most of you will start your computing experience with an operating system called Microsoft Windows, we will use Windows throughout the course.

With the desktop, you can use **shortcuts** to find folders, files, or programs quickly. You can identify a shortcut by checking if there is a curving arrow on the bottom left-hand side of the icon, as seen in Figure 2.6.



**Figure 2.6:** Example of a shortcut

Let's look in more detail at the desktop and icons that you can find on a computer:

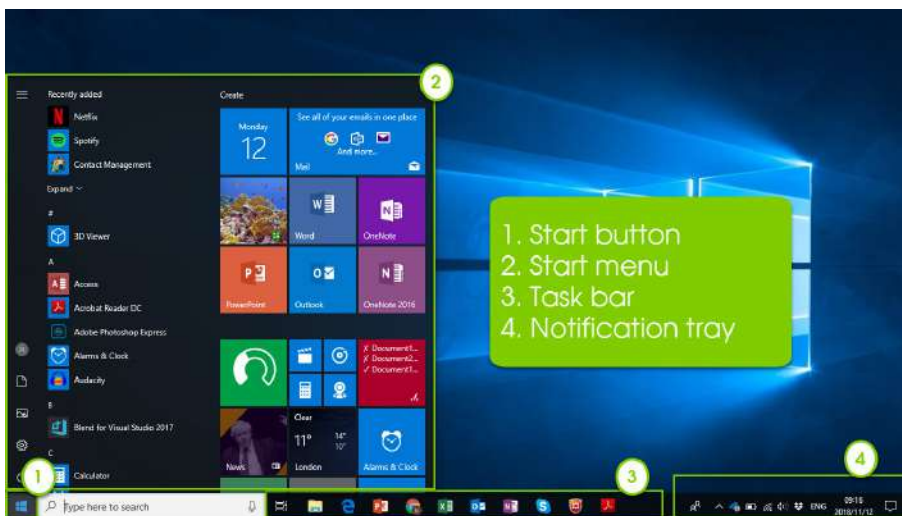

**Figure 2.7:** Desktop components



**Something to know**

An icon is a picture that shows a file, folder, or a program. Each icon is different for each type of file or program.

## THE START BUTTON

The *Start* button can be found at the bottom left-hand corner of the desktop. It allows you to open programs, files, or folders on the computer. The *Start* menu appears when you click on the *Start* button. From there, you can select the application, folder, or file you want to open by clicking on it.

## THE TASKBAR

The taskbar can be found at the bottom of the screen, as seen in Figure 2.7. It shows a button for each open folder, file, or application. When you click on any of the buttons on the taskbar, it will open the file, folder, or application, and therefore, becomes an active window.

The taskbar also has the *Start* button on the left-hand side and the **notification tray** on the right-hand side. You can perform certain functions, such as change the time, volume, or connect to the **Wi-Fi** by selecting the icons in the notification tray.



### Activity 2.1

- The following steps are performed when starting up, using and shutting down a computer. The steps are in the incorrect order, however. Arrange the steps in the correct order.
  - Enter the password
  - Switch on the monitor
  - Session begins
  - Switch on the power button
  - Click on Log out
  - Enter the username
  - Computer session ends
  - Switch off the monitor and power
  - Shut down computer
- State whether the following are True or False. If false, give the correct answer.
  - A password should always be secret.
  - The keyboard is the most important hardware device used to control the computer.
  - The hour-glass icon shows that you must wait while the computer is doing a task.
- Match the terms in Column A with the correct description in Column B:

COLUMN A	COLUMN B
1. Desktop	A. This is the main screen of the GUI and consists of a system of icons on a screen
2. Shortcut	B. This is when the computer loads the operating system and checks that all the components are in good order
3. Boot	C. The computer identifies the user with this name
4. Username	D. You can use this to find files, programs, or files quickly
5. Icon	E. Allows you to access the time and volume icons on the computer
	F. This is a picture that shows a file, folder, or a program
	G. It allows you to open programs, files, or folders on the computer

... continued

4. Logging off and then switching off the computer when you are done using it, is actually quite important. Answer the following questions regarding this statement:
  - a. Give two reasons why switching off the computer after use is important.
  - b. Does logging off switch off the computer? Motivate your answer.
  - c. Briefly explain why it takes time for a computer to start up and shut down.

## THIS PC, FILE MANAGER, MY DOCUMENTS AND RECYCLE BIN

After you click on the *This PC*, *My Documents*, or the *Recycle Bin* icon, a folder will open in a window on the desktop.

- **This PC:** When you open the *This PC* folder, it will give you information about the different storage disks, external hard drives, or hard disks on the computer.

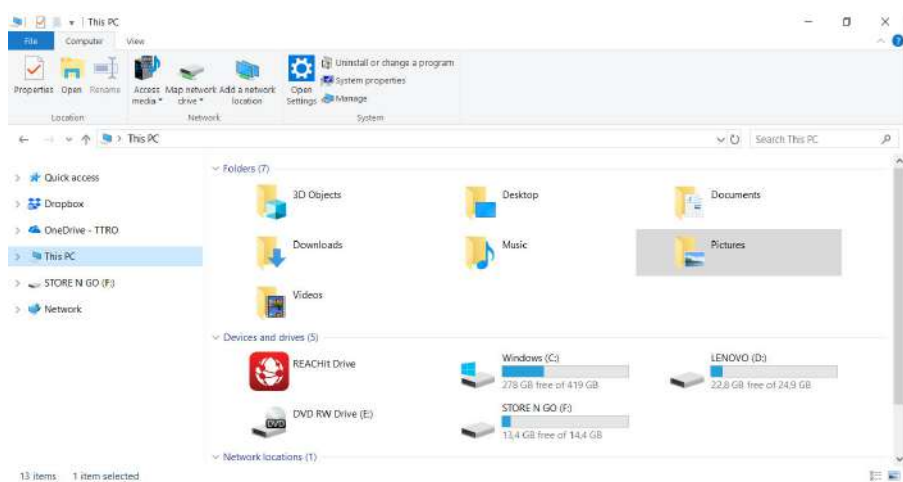

**Figure 2.8:** *This PC* folder

- **File manager:** A file manager is an application that helps manage the file system on a computer.
- **My Documents:** When you open this folder by double clicking on the icon, you can find your documents, music, pictures and other files. These files are stored in the *My Documents* folder on the computer's hard disk.
- **Recycle Bin:** When you delete items, such as folders or files from the computer, they are stored temporarily in the *Recycle Bin*. If you deleted a file by mistake, it can be restored to its original folder from the *Recycle Bin*. The files or folders in the *Recycle Bin* can also be permanently deleted by deleting them.

## ACCESSING APPLICATIONS

You can access the different applications on the computer by using the *Start* menu. Click on the *Start* button and then scroll through the alphabetical list. If you want to save time, you can limit the scrolling by selecting any letter from the alphabetical list. From there, you can choose the letter that the application begins with.

If you are still having difficulty finding the application that you are looking for, type in the name of the application in the search box on the taskbar.



### Something to know

In older versions of Windows, *This PC* is known as *Computer*.

## GETTING TO KNOW WINDOWS

Zama needs to use Microsoft Word for a small project. Let's look at an example of how Zama uses Microsoft Word.



### Guided Activity 2.2

1. To open Word, she clicks on the *Start* button and then moves the mouse pointer onto the Word icon and clicks on it, as seen in Figure 2.9.



**Figure 2.9:** Opening the Word application from the Start menu

2. Word will open in a separate window and the Word icon will appear on the taskbar.

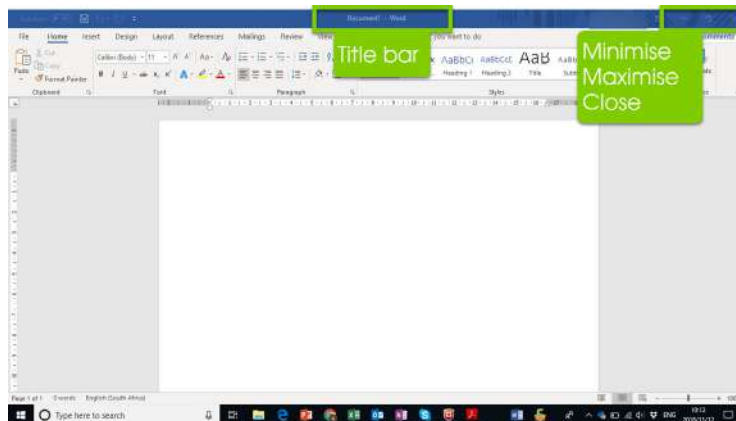

**Figure 2.10:** Word window

## SOME THINGS TO NOTE ABOUT WINDOWS

The following section will look at the different features of windows, using the Word window as an example.

The title bar is found at the top of the window and the name of the open file can be seen on the title bar. Since the document is not named yet, the title bar will be *Document1-Word*.



**Figure 2.11:** The title bar

To minimise the taskbar, click on the *Minimise* button on the top-right corner of the window, as seen below.



**Figure 2.12:** *The Minimise button*

To enlarge the window or make it bigger, click on the *Maximise* button, as shown below. This can also be done by dragging the window from the title bar to the top of the screen.



**Figure 2.13:** *The Maximise button*

To close a window, click on the *Close* button (which is the x in the top-right corner of the window), as shown below.



**Figure 2.14:** *The Close button*

## FILE MANAGEMENT

### OPENING A DOCUMENT AND SAVING DATA

Now we must open the document and save the data we need on Word. Let us see how she does this.

#### Guided Activity 2.3

Do the following with the help of your teacher.

1. Open Word.
2. Type two short lines of the letter “a”, just so that you have typed something. (To begin a new line, press *Enter* on the keyboard.)
3. The text will always appear on the left of the cursor when you type.
4. Now that you have typed the two lines, you can save the file. To save the file, select *FILE*, then *SAVE* from the menu bar. When the *Save As* dialogue box appears, save the file with the file name ‘Test’ in the *File name* field in the dialogue box.
5. Click the *Save* button, so that the file can be saved and then close the dialogue box.
6. In the Word document, the name of the file will now be ‘Test’. Close the window by clicking on the *Close* button on the title bar.

You can follow this example in the video on the right.

When you are done using the computer, you can switch it off by first clicking on the *Start* button, then on the *Power* button where you choose *Shut down* to shut down the computer.



#### Video

Create a video showing the steps on how to open and save data in a Word document. These steps are explained on the left (Steps 1 to 6).



#### Something to know

Remember, shutting down a computer might differ from computer to computer!

## OPENING A FILE

In the previous example, you saved a document with the file name 'Test'. Now let's learn how to open the saved file.



### Guided Activity 2.4

Let's do the following:

1. Open Word. To open the required file, select *File* then *Open* from the menu bar.
2. When the *Open* dialogue box opens, select *Test.docx* from the list box.
3. Click the *Open* button, as highlighted in green in Figure 2.15, which then opens the document in Word.

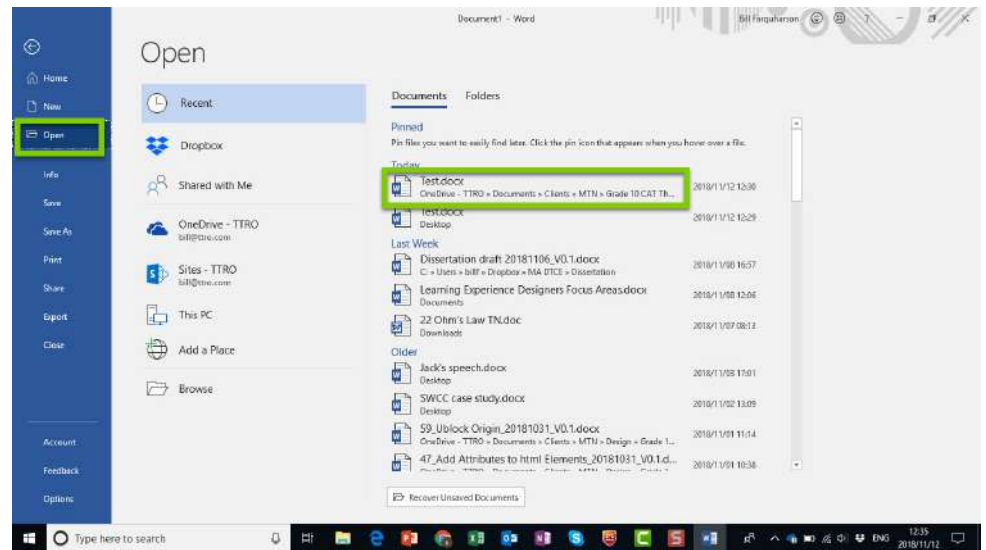

Figure 2.15: Open dialogue box

## PRINTING A DOCUMENT

You will learn how to print documents when you study word processing. Refer to Chapter 1: Introduction to Word Processing in the Practical Book for more information.



### Activity 2.2

Do the following at your computer:

1. Switch on the computer.
2. Find Word using the search box in the taskbar.
3. Use the mouse to open the Word application.
4. Type two to three sentences about why CAT, as a subject, is important.
5. Save the file and then close it.
6. Open the file that you just saved in (5).
7. Print Preview the document.
8. Close the application.

## 2.2 Posture and ergonomics

As computing takes over our lives more and more, typing is one of the most important and necessary skills that you will ever learn.

**Touch typing** is all about making sure that each finger has its own place on the keyboard. Because of that, you do not have to look down on the keyboard while typing, which makes your typing speed much faster.

Let's look at the following benefits of being able to touch type:

- **Speed:** This is the most obvious advantage of touch typing. On average, you can easily reach typing speeds of 75 to 80 words per minute. Comparing that to the average of ten words per minute of someone who does not touch type, you can see that it is much faster.
- **Time:** If you increase your typing time, you obviously decrease the time it will take you to complete a document. A person who types with two fingers at ten words per minute, will take 17 minutes to type a 170-word document. Typing at 60 words per minute will do the same document in four minutes.
- **Decrease fatigue:** Typing is very tiring when it is done over long periods of time. Learning to touch type reduces this exhaustion, as you do not have to focus on two things at a time. It also prevents you from looking up and down the whole time, placing less strain on your eyes, neck and spine.
- **Health:** Touch typing is better for your health, because you do not hunch over and look at the keys while using your fingers. This helps to reduce the strain on your joints.
- **Accuracy:** The better you can touch type, the less typing errors you will make, because you are looking at what you type, and not having to look down and find the right keys.

### SOCIAL IMPLICATIONS: CORRECT TYPING POSTURE

Posture is defined as the position in which a person holds his or her body when sitting or walking. Sitting in front of a computer for long periods of time, even with a good posture, can lead to tiredness or eye discomfort.

Having the correct posture also helps you to type correctly and more efficiently.

A tip for having a good posture when using the computer, is to position yourself so that your belly button is in line with the letter "H" on the keyboard. You can see an example of this in Figure 2.16.

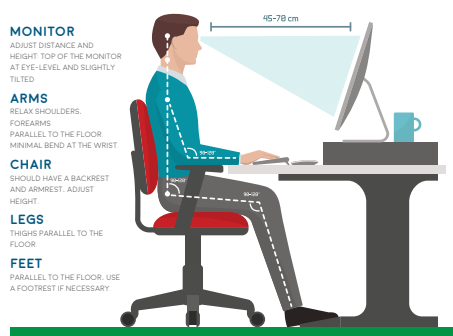

**Figure 2.16:** Correct body posture

The following are elements for maintaining a good posture:

- **Body:** Your back should be straight, upright and relaxed, but comfortable. For your back to be supported, it should be aligned with the chair's backrest. Do not lean too far forward as this will cause discomfort later.
- **Feet:** For your feet to feel comfortable, make sure that they are flat on the floor, or on a foot rest.
- **Knees and hips:** Push your hips as far back as they can go in the chair. As seen in Figure 2.16, your knees and hips should form a 90° angle when sitting on the chair. Also, make sure your knees do not touch the chair.
- **Arms, wrists, fingers and hands:** Your arms should be placed horizontally in a 90° angle, your wrists should be in a neutral position and your fingers should be placed on the home row.
- **Eyes:** Your eyes should focus on the text that you are typing on the screen. To position your screen, make sure it is slightly lower than your eye level.

Having the wrong posture when sitting in front of a computer, can cause various health problems, such as:

- **Posture-related injuries:** Posture-related injuries include back and neck pain, headaches, and shoulder and arm pain. Poor posture can affect your spine alignment, causing problems with blood vessels, and ultimately leading to blood clots and varicose veins. When your body is slumped over for long periods of time, you are more likely to clench your jaw and tighten your facial muscles. This can lead to jaw pain and headaches.
- **Computer-related overuse injuries:** The muscles and tendons in the elbows, wrists and hands can become painful with repetitive movement and bad posture. Symptoms include pain, swelling, stiffness of the joints, weakness and numbness.
- **Eye strain:** Eye strain is caused by focusing the eyes at the same distant point for long periods of time, working with the screen too close to the eyes and looking at the illuminated computer screen for too long.
- **Laptop-related injuries:** Laptops were never meant to be used for long periods of time. The fact that the screen and the keyboard are very close together, it can cause eye strain, as well as a bad posture. Even carrying the laptop around can put strain on your muscles and joints.

## ERGONOMICS

Ergonomics is the study of the way in which humans work with the goal of increasing productivity, comfort and safety.

When speaking of computer ergonomics, the focus is mainly on the way in which people use computers, and how this can be improved to make people more comfortable and reduce discomfort and injuries.

Key ergonomic guidelines for safe computer usage include:

- Sit up straight with your back perpendicular to the ground.
- Your forearms should be at the same height as your mouse and keyboard.
- Your feet should be placed firmly on the ground or on a foot rest.

- The back and height of your chair, as well as the height of your armrests should be adjusted to support your body in this position.
- The monitor should be positioned at eye level and roughly 50 cm away from you. You may need to place something under the monitor to increase its height.
- The monitor should be tilted upwards to reduce glare.
- You should stand up and take regular breaks.

## PREVENTION

Prevention is always better than cure. Many people suffer from posture-related injuries. Health problems related to poor posture and ergonomics can be prevented in different ways.

To prevent a repetitive strain injury, you should:

- Make sure your forearms are level with your mouse and keyboard.
- Make sure the mouse is positioned close to the keyboard.
- Take regular breaks and let your arms relax when you are not typing.

To avoid eye strain:

- Make sure that there is no glare on the monitor.
- Do not sit too close to the monitor.
- Make sure that the monitor is placed at eye level (or slightly lower).
- Take regular breaks to focus on far-away objects.



### Activity 2.3

Use the image below to answer the questions that follow.

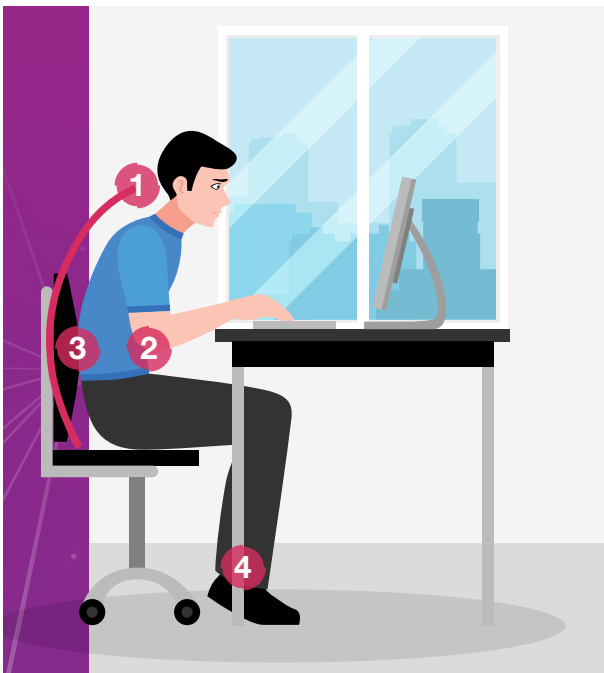

1. Is this person using good posture?
2. Motivate your answer by using the numbers in the diagram to guide you.
3. Explain why a good chair is important to assist you in maintaining a good posture.

## REVISION ACTIVITY

- When you are working on a computer that is used by more than one person, you will often be asked to enter a user name and password soon after the computer has been switched on. Give two reasons why you should never share your password with anybody else. (2)
- Match the mouse action in Column B with the desired outcome in Column A. Write down only the number from Column A and the matching letter from Column B.

COLUMN A	COLUMN B
1. Scroll up and down a web page	A. Click the left mouse button once
2. Select an icon on the desktop	B. Double-click the left mouse button
3. Open an application using a desktop icon	C. Click and hold the left mouse button while moving the mouse
4. Move an icon from one side of the desktop to another	D. Roll the scroll button of the mouse backwards and forwards

- Answer the following questions about a GUI. (4)
  - What does the acronym GUI stand for? (1)
  - What is the main screen of the Windows 10 GUI called? (1)
  - What is the function of an icon? (2)
- What does the arrow in the bottom left corner of the icon below indicate? (1)



- Study the image of a Windows 10 desktop below

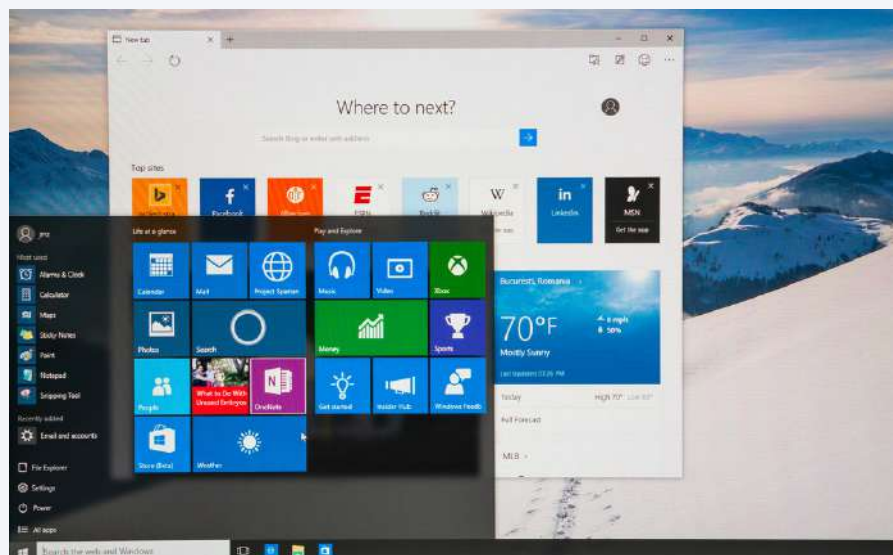

- Label the parts of the desktop labelled A, B, C and D. (4)

... continued

## REVISION ACTIVITY

... continued

6. Study the icon below and answer the questions that follow:



- 6.1 What application can be accessed by double-clicking the above icon? (1)
- 6.2 Explain to someone who is NOT familiar with Windows 10 how you would use the application. (3)
7. Explain the difference between *saving* and *closing* a file. (2)
8. Give four tips to avoid eye strain when using a computer monitor. (4)
9. Use the image below to guide learners about having good posture when using a computer.

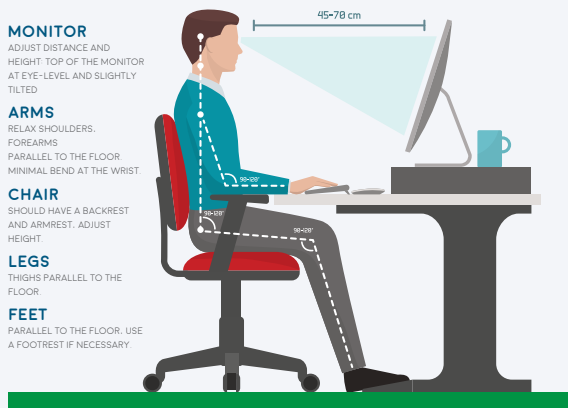

- 9.1 Mention at least four points. (4)

TOTAL: [29]

## AT THE END OF THE CHAPTER

Use the checklist to make sure that you worked through the following and that you understand it.

NO.	DID YOU ...	YES	NO
1.	Learn how to switch on a computer.		
2.	Learn how to use a mouse correctly.		
3.	Identify the different icons and what it means when using a mouse.		
4.	Use your desktop.		
5.	Learn about the operating system and the different components of the OS.		
6.	Learn about the GUI interfaces.		
7.	Understand the importance of using the correct posture when using the computer.		
8.	Understand the importance of ergonomics.		

## FILE MANAGEMENT

CHAPTER OVERVIEW **Unit 3.1** Basic concepts of file management**Unit 3.2** File types  
At the end of this chapter, you should be able to:

- Understand the basic concepts used in file management.
- Organise files and folders on the computer.
- Identify the different file types.

## INTRODUCTION

Having an effective computer filing system can make a huge difference in your everyday life. Firstly, it helps to save time, but most importantly, it helps you to be more organised.

In this chapter, we look at what file organisation is, how we can achieve file organisation and the different types of files you can find on your computer. You will also learn about the importance of file management, and how you can organise, delete, restore, move, view and sort files and folders. Furthermore, you will learn about the basic accessories that Windows comes with, as well as how to install a printer.



## Take note

Before you can start with this chapter, you must have worked through the chapter on how to use a computer.

## 3.1 Basic concepts of file management

File management on a computer is similar to filing documents in a filing cabinet. A filing cabinet is used to store paper files in cardboard folders. In the same way, we can store files and folders on a computer.

Figure 3.1 shows the *This PC* folder with the sub-folder *Music*. This folder contains sub-folders that are organised according to the name of the artist or group. This is to give you an idea of how file management looks on a computer. In Windows, folders are used to organise files.

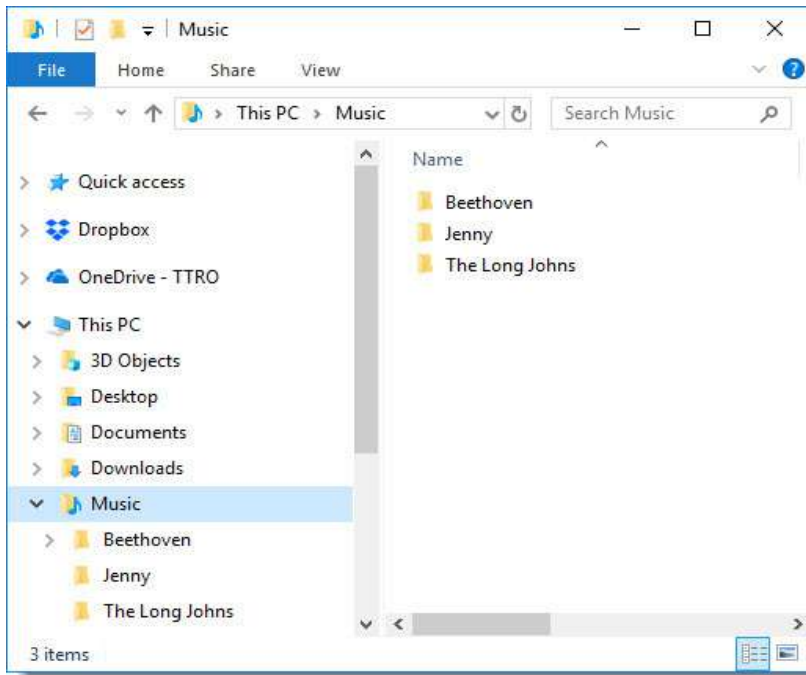

**Figure 3.1:** Folders used for file management

Folders are stored on a drive in a computer. Data is stored on and retrieved from a **disk drive**. Each drive will indicate the type of storage medium, for example, whether it is a hard disk, USB drive, CD, DVD, or so on. Figure 3.2 shows an example of the different drives that can be found on a computer.

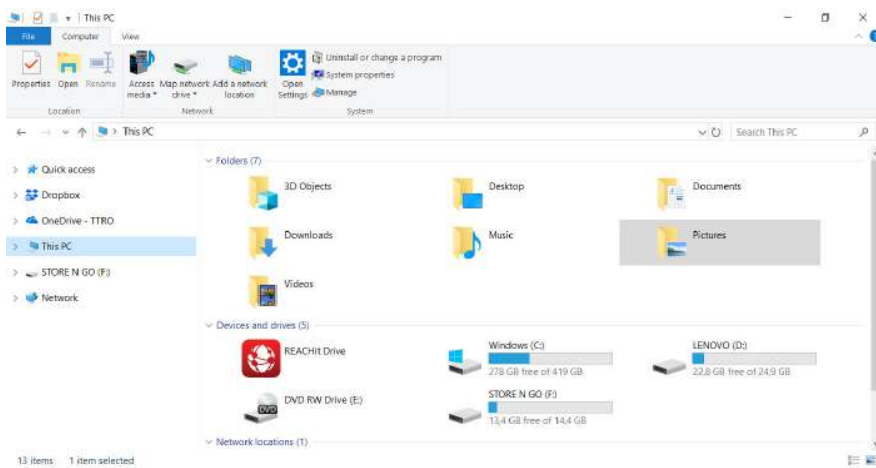

**Figure 3.2:** Different storage media on a computer

The capital letters and colon indicate what type of disk it is. For example, from Figure 3.2, you can see the following:

- The C: Which is also known as the C-drive, usually refers to the **hard disk drive (HDD)**.
- The D: Which is also known as the D-drive, usually refers to a CD or DVD drive.
- Other letters are also used to indicate storage media, for example, in this case **F:**, which refers to a removable disk (USB). Storage media, such as DVDs, USBs and hard drives, do not save data to the disks on the computer.

## FOLDERS

A Windows operating system organises its drives, folders and files in a hierarchical folder structure. Files are stored on a computer inside folders. Folders are used to organise a computer's files so that it can be found easier. A folder will contain sub-folders and then files.

In the following example, we will explain a folder by comparing it to a tree. The structure is the shape of a pyramid, where each row of items is linked to the items beneath it. Because of this pyramidal structure, this hierarchical structure is also known as an “inverted tree”.

Figure 3.3 shows an example of an inverted tree.

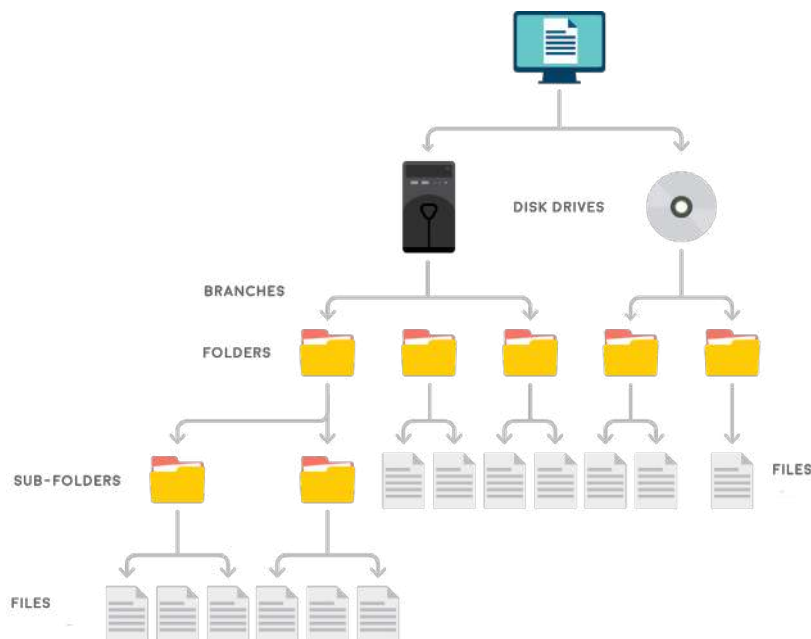

**Figure 3.3:** Hierarchical tree

The different drives, such as the different hard drives, CD/DVD drive, USB drives, as well as network drives, are found in the row below the root. Folders linked to the specific drives are then shown in the next row.

Any sub-folders and files found in the folder above are shown in the next row. This pattern continues until the final row only contains files.

The highest level of the tree structure of a drive is, therefore, called the **root directory** and is stored on the hard-disk drive of a computer. The documents then form a sub-folder of the root directory C-drive, which is written as C:\.

## FILE PATH

A **file path** shows the location of where a file, web page, or other item is located on the computer. The file path shows you to which storage device the file is saved (i.e. the drive letter), in which folder and sub-folders the file is saved, the name of the file and finally, the type of file (given by the **file extension**).

For example, Jane has a music folder where she keeps her songs. Figure 3.4 shows an example of this file path.

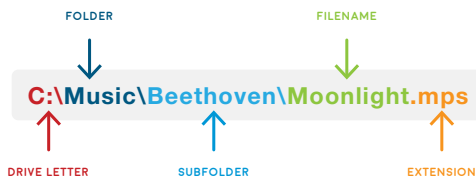

**Figure 3.4:** Example of a file path

As Figure 3.4 shows, each file's unique file path starts with the storage device drive letter. After the drive letter, you will see the name of the file's folders and sub-folders. A back slash (\) is used to separate the drive letter, and the different folders and files. Finally, the file path ends with the name and extension of the file.

Windows file names have two parts; the first part is the file name and then a period followed by an extension. A file extension or file name extension is found at the end of a file name and shows what type of file it is in Microsoft Windows. The extension is a three- or four-letter abbreviation that identifies the type of file. For example, in the file name, Moonlight.mp3, the extension is mp3.

Later in this chapter, you will learn more about the different file extensions.

## FINDING A FILE PATH

To find the file path of a folder, click on the address bar in File explorer.



### Guided Activity 3.1

You can do this as follows:

1. Open the *Computer* window from the *Start* menu.
2. Browse to the folder for which you want the file path.
3. Click on the address bar to see the folder's address.

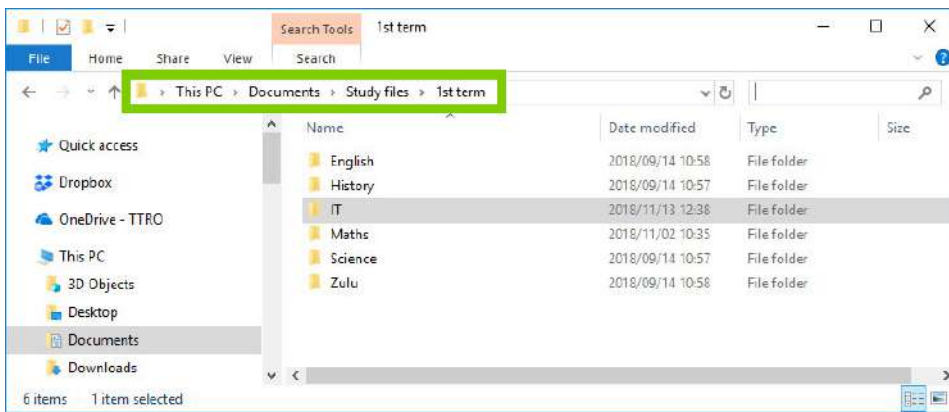

**Figure 3.5:** Address bar



### Something to know

When using file paths in Windows, you must always use back slashes (and NOT forward slashes). Windows uses back slashes for paths, although everything else seems to use forward slashes.



### Guided Activity 3.2

If you want to know what a file's unique file path is, you can find it using the *Properties* window.

1. Open the computer window from the *Start* menu.
2. Look for the file you want the file path for.
3. Right click on the file and select the *Properties* option.
4. Click on the *Security* tab.
5. The file path is given at the top of the security tab as the *Object* name.

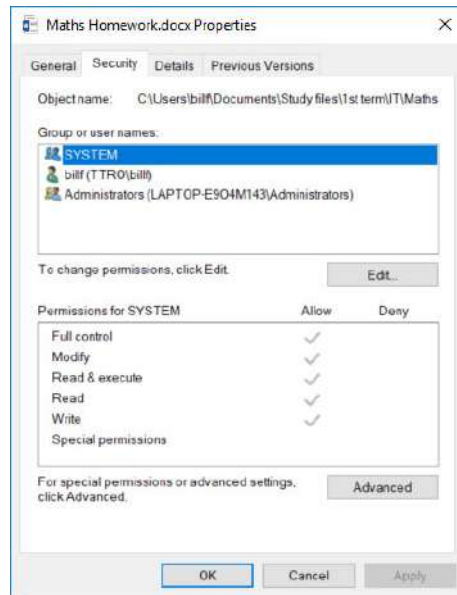

Figure 3.6: Reading a file path from the properties window



### Activity 3.1

1. Define the following terms:
  - a. File path
  - b. Disk drive
  - c. Folders
2. Answer the following questions based on the file path below:

**C:\Documents\School\Maths.docx**

- a. What is shown in the file path above?
  - b. To what does "C:\" refer?
  - c. A file name consists of two elements. What are they in this diagram?
3. Using the figure below, provide the file path to get to the file: *Communication.pdf*.

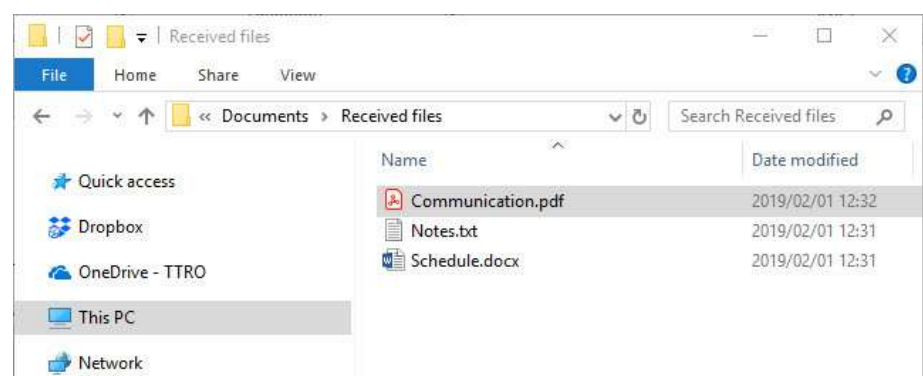

Figure 3.7: Determining the file path for the file, *Communication.pdf*



### FILE MANAGEMENT



[https://www.youtube.com/watch?v=k-EID5\\_2D9U](https://www.youtube.com/watch?v=k-EID5_2D9U)

## ORGANISING FILES AND FOLDERS

Organising files on your computer is an important task, as it can ultimately save you lots of time and effort! For you to find files and folders on the computer, it must be organised properly. It is, therefore, important for you to place files in folders and give them the correct names.

In Microsoft Windows, this can be done in different ways. This section will look at the easiest ways in which files can be copied or moved between folders, renamed and deleted. You will also learn about how to search for files on a computer.

Before you can start organising your computer, you first need to see how the computer is currently organised.

### USING A FILE MANAGER (THIS PC)

A file manager is a built-in application that is used to organise files and folders. To open the file manager, double click on the *This PC* icon. The *This PC* folder will open up in a new window. From here, you can start working with the files and folders.



#### Guided Activity 3.3

Practise using the file manager on your computer by following the steps below:

1. Click on the *Start* menu button in the bottom-left corner of the screen.
2. Once the *Start* menu opens, type in the word “explorer”. You should see a *File explorer* option appear in the *Start* menu.
3. Click on the *File explorer* option, which will open the file explorer on the computer.
4. Once opened, click on the *This PC* option in the left panel. Here, it will show you the main folders. From here, you can explore the computer’s organisational system by looking through the folder structure.

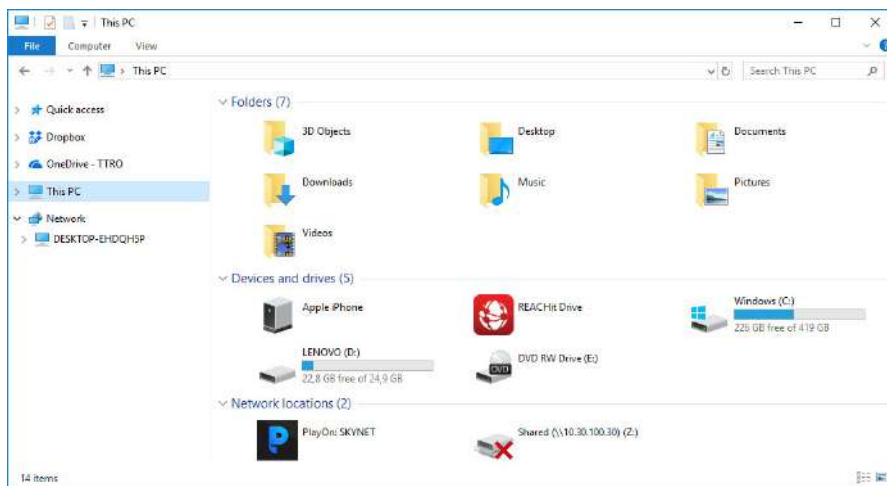

**Figure 3.8:** Checking how the computer is currently organised

In the *This PC* screen, the storage devices are indicated by grey and black icons, and include the drive letter in their name. The figure shows that there are four storage devices – i.e. Computer (C:), Data (D:), USB Drive (F:) and Recovery (E:). By double-clicking on any of these storage devices, it will open, and you can browse the files and folders stored in it. If you want to open any files or folders, you should double-click on them.

After you have examined the different files and folders on the computer, you can start organising them.

As you have learned, files are stored on a computer inside directories (called folders in Microsoft Windows). These folders are used to help organise a computer's files so that files can be found more easily. Each folder can contain any number of files or sub-folders. For example, a music listener might create a *Music* folder with all her music files in it.

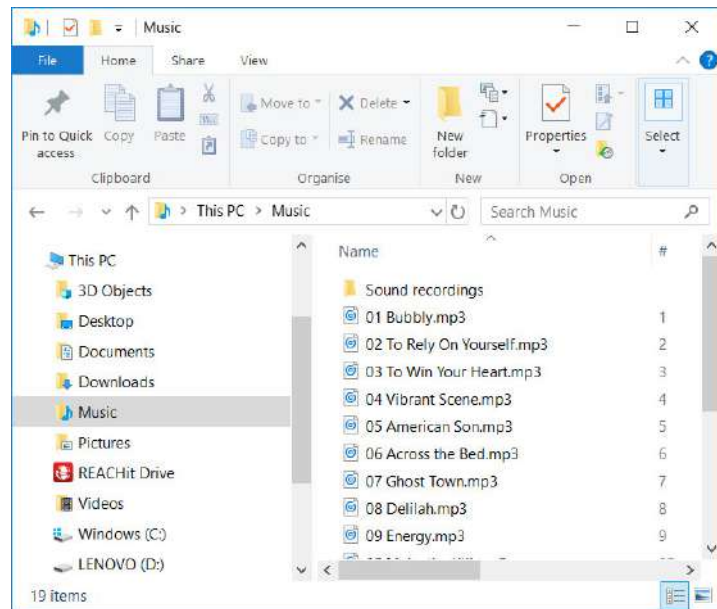

Figure 3.9: A folder containing a number of music files

A more organised music listener might have a *Music* folder as the first folder, and then sub-folders for each artist. It might even have a sub-folder for each style of music and then have folders inside of that for each artist. This would make it much easier to find songs by a specific artist.

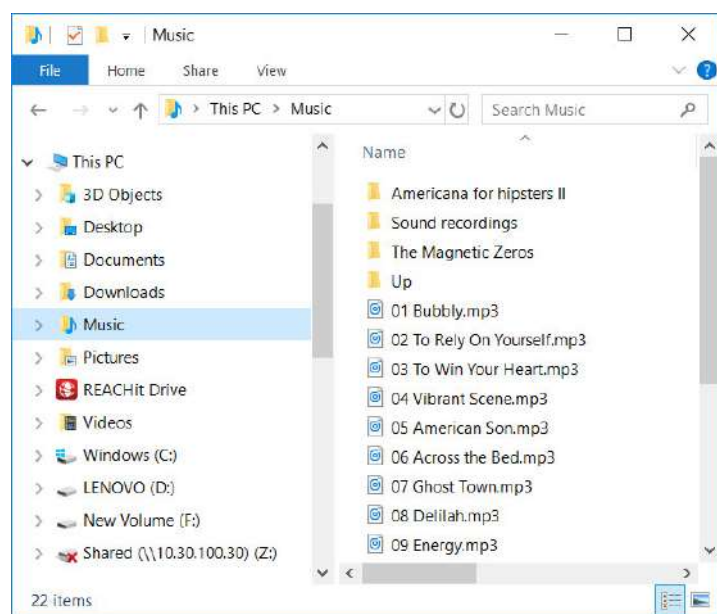

Figure 3.10: Folders can contain both files and folders



HOW TO ORGANISE  
FILES AND FOLDERS



<https://www.youtube.com/watch?v=HDmwiJxZlrw>

A similar strategy can be used on all storage devices to make it easier to find important files and folders.

## CREATING AND NAMING FOLDERS AND FILES

An important part of having an effective file structure is creating folders and sub-folders to organise your files.



### Guided Activity 3.4

To create a new folder:

1. Using the *File explorer*, go to the location where you want to create a folder.
2. Open the *Action* menu by either right clicking, or by using the *ALT-F* shortcut key.
3. Hold the mouse cursor over the *New* option and select the *Folder* option.
4. Enter a name for the new folder and press *Enter* on the keyboard.

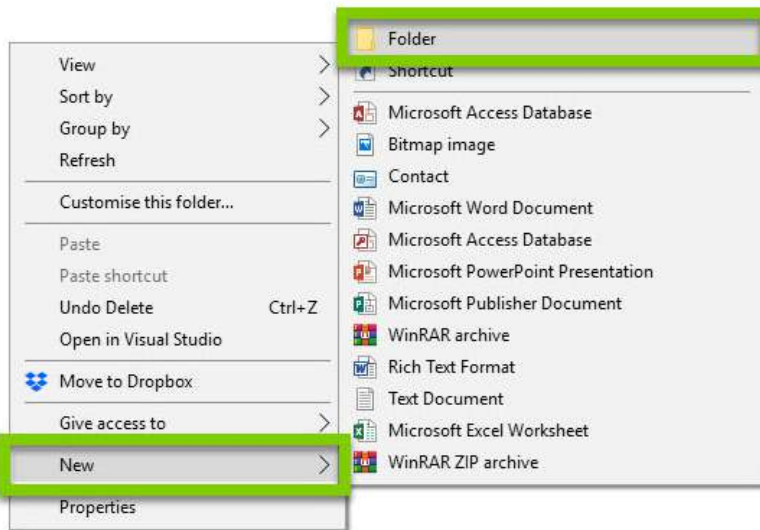

Figure 3.11: Creating a new folder

The same procedure can be used to create new files. However, instead of selecting the *Folder* option, the file type you want to create should be selected.

To create a new file:

1. Using the *File explorer*, go to the folder where you want to create a file, for example, *Documents*.
2. Right click on an empty section of the folder.
3. Click on *New*, select the type of file that you want to create.
4. Enter a new name for the file.
5. Press *Enter*.

## FILE NAMING, CONVENTIONS AND PROPERTIES

### FILE NAMING AND CONVENTIONS

A file name is used to identify a file on the computer. This is the best method of organising files and folders on the computer. Naming files properly helps you to navigate and locate files and folders easily.



### MANAGING FOLDERS AND FILES

An interesting way to organise folders and files is shown in the following YouTube video. This is just to give you an idea of how you can do it. However, in the end, you must use a system that works for you.



<https://www.youtube.com/watch?v=uSnpAnhV2Jo>

A file-naming convention (FNC) helps keep the computer clutter-free and allows you to do the following:

- Know the contents of a file before you open it
- Navigate through long lists of files for the one that you are looking for
- Store different versions of the same document by naming them according to date

Best practices for naming files:

- Keep file names short, but meaningful.
- Include useful information, such as the name of the project or document on which you are working.
- Include the version number (e.g. v1 or -v1) and the date if there is more than one more version. Dates should always appear as yyyy/mm/dd to organise the files in order.

Things to avoid when naming files:

- Symbol characters, such as “\ / < > | “ ? [ ] ; = + & \$ α β”
- Abbreviations that are not easy to understand
- Simple words, such as “draft”, “current” or “document”.

## FILE PROPERTIES

The *File properties* window shows you a range of information about a file, such as its file type, size, author, title and when it was changed last. The *Properties* window will also give you information on how you can manipulate the file.



### Guided Activity 3.5

To see the properties of a file, right click on the file name and then click on *Properties*.

1. The *Properties* dialogue box will give you information about the file, as you can see in the figure below.

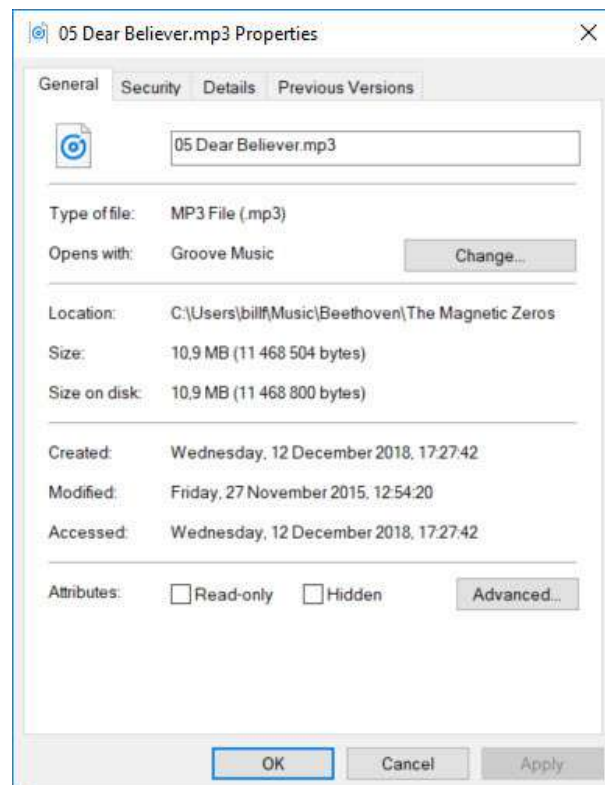

Figure 3.12: *Properties* dialogue box



### Something to know

When giving the new file a name, make sure that you do not accidentally change the file extension. Changing the file extension will prevent Windows from opening the file correctly.

## RENAMING FILES

The *Rename* command allows you to change the name of files. As with *Cut* and *Copy*, there are three different ways to rename files.

**Table 3.1:** How to rename files

ACTION MENU	SHORTCUT KEY	LEFT CLICK
<ol style="list-style-type: none"> <li>1. Select the files you want to rename.</li> <li>2. Right click on one of the selected files.</li> <li>3. From the <i>Action</i> menu, select the <i>Rename</i> option.</li> <li>4. Enter a new name for the file and press the <i>Enter</i> key.</li> </ol>	<ol style="list-style-type: none"> <li>1. Select the file you want to rename.</li> <li>2. Press the <i>F2</i> key on the keyboard.</li> <li>3. Enter a new name for the file and press the <i>Enter</i> key.</li> </ol>	<ol style="list-style-type: none"> <li>1. Select the file you want to rename.</li> <li>2. Using the mouse, click on the name of the selected file.</li> <li>3. Enter a new name for the file and press the <i>Enter</i> key.</li> </ol>

When naming files, it is important that you name the files clearly and in an orderly way. The following are pointers to help you rename files and folders in an organised way:

- Avoid using a structure that is too difficult to follow.
- Since files are organised alphabetically, you need to think about the way in which you name files.
- Make sure that you can identify similar files based on the file names.
- Use the dash symbol to separate different items in a file name (for example, the name and date).

## COPYING FILES

When you copy a file, a duplicate of the file is created and stored on the computer's clipboard. This duplicate file can then be copied onto any storage medium connected to the computer, using the *Paste* command.

There are three ways that you can copy and paste files.

**Table 3.2:** How to copy and paste files

ACTION MENU	SHORTCUT KEY	DRAG AND DROP
<ol style="list-style-type: none"> <li>1. Select the files you want to copy.</li> <li>2. Right click on one of the selected files.</li> <li>3. From the drop-down <i>Action</i> menu, select <i>Copy</i>.</li> <li>4. Navigate to the folder where you want to place the copied file.</li> <li>5. Right click on the folder and select the <i>Paste</i> option from the <i>Action</i> menu.</li> </ol>	<ol style="list-style-type: none"> <li>1. Select the file you want to copy.</li> <li>2. Press <i>Ctrl+C</i> on the keyboard.</li> <li>3. Navigate to the folder where you want to place the copied files.</li> <li>4. Press <i>Ctrl+V</i> on the keyboard to paste the files.</li> </ol>	<ol style="list-style-type: none"> <li>1. Select the files you want to copy.</li> <li>2. In a different <i>File explorer</i> window, navigate to the folder where you want to place the copied files.</li> <li>3. While pressing the <i>Ctrl</i> key on the keyboard, drag the files from the source folder to the destination folder.</li> <li>4. Drop the files once they are over the destination folder.</li> </ol>



### Something to know

Applying the **keyboarding** skills you have learned will help you rename files and folders much quicker.



### Something to know

Files are copied when you want to share them, or back them up for safety.



### COPYING AND MOVING FILES

Use the section of the following video to create an animation about showing what it means to copy a file:



<https://www.youtube.com/watch?v=F7mAoaOf0ts&t=18s>



### Something to know

Files are moved when you want to organise them.

## MOVING FILES

When moving files, the file or files that you move are copied to a new destination, but then deleted from its original destination. When doing this, you have not created a copy file, but you have moved a file from one folder to another folder.

To move files, you need to *cut* and *paste* them, and NOT copy and paste them.

**Table 3.3:** How to move files

ACTION MENU	SHORTCUT KEY	DRAG AND DROP
<ol style="list-style-type: none"> <li>1. Select the files you want to copy.</li> <li>2. Right click on one of the selected files.</li> <li>3. From the <i>Action</i> menu, select the <i>Cut</i> option.</li> <li>4. Choose the folder where you want to place the copied files.</li> <li>5. Right click on the folder and select the <i>Paste</i> option from the <i>Action</i> menu.</li> </ol>	<ol style="list-style-type: none"> <li>1. Select the file you want to copy.</li> <li>2. Press <i>Ctrl+X</i> on the keyboard.</li> <li>3. Navigate to the folder where you want to place the copied files.</li> <li>4. Press <i>Ctrl+V</i> on the keyboard to paste the files.</li> </ol>	<ol style="list-style-type: none"> <li>1. Select the file you want to copy.</li> <li>2. In a different <i>File explorer</i> window, navigate to the folder where you want to place the copied files.</li> <li>3. While pressing the <i>Shift</i> key on the keyboard, drag the files from the source folder to the destination folder.</li> <li>4. Drop the files once they are over the destination folder.</li> </ol>

## SEARCHING FOR FILES

If you are struggling to find a file on the computer, you can always search for it. The search function allows you to look for any file that is on the computer.

To search for a file in Windows 10, you can do the following:

1. Next to the *Start* button, you can type to search for the file you are looking for.

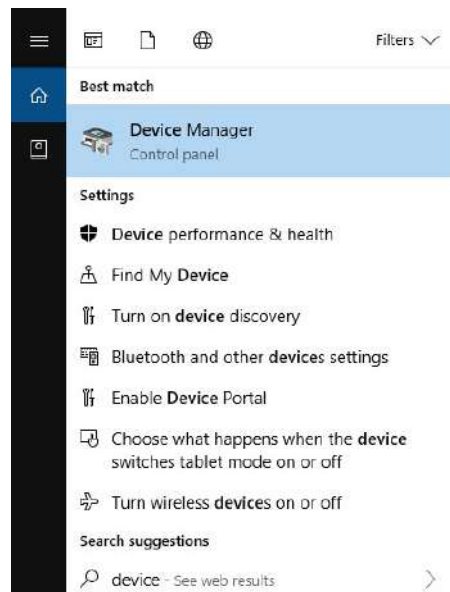

**Figure 3.13:** Searching for files

2. In the example above, the user typed in the word "device". You can see the search results above the search box.

When searching for files,

- **Use different search terms:** For example, if you are looking for a spreadsheet file, try using a different file name. You could have changed the file name while saving the file.
- **Last application:** If you used a specific application to open and edit the file, you can click on *File > Open > Recent*. The file you are looking for might appear in the list of files that you edited recently.
- **Move and rename the file:** After you have found the file, you can give it a new file name. Then, move it to a folder so that you can find it more easily at a later stage. For example, if it is a new song that you downloaded, move it to the *Music* folder.

## DELETING FILES

The *Delete* command enables you to remove files from the storage device. This command can be used to either remove files that you do not need anymore, or to make more space on the storage device.

In Microsoft Windows, deleted files are moved to the *Recycle Bin*. The *Recycle Bin* is a temporary folder where deleted files are stored until you remove them from the bin. Any files you delete will first be moved to the *Recycle Bin* before they are permanently deleted.

The following tables show how you can delete files from the computer and how these files can be deleted from the *Recycle Bin*.

**Table 3.4:** *How to use the Recycle Bin*

ACTION MENU	SHORTCUT KEY
<ol style="list-style-type: none"> <li>1. Select the files you want to remove.</li> <li>2. Right click on one of the selected files.</li> <li>3. From the <i>Action</i> menu, select the <i>Delete</i> option.</li> <li>4. Click on the <i>Yes</i> button to remove the files.</li> </ol>	<ol style="list-style-type: none"> <li>1. Select the files you want to remove.</li> <li>2. Press the <i>Delete</i> key on the keyboard.</li> <li>3. Click on the <i>Yes</i> button to remove the files.</li> </ol>

**Table 3.5:** *How to remove files from the computer permanently*

EMPTY THE RECYCLING BIN	SHORTCUT KEY
<ol style="list-style-type: none"> <li>1. Remove the files from the computer, as shown in the previous steps.</li> <li>2. Go to the computer's desktop.</li> <li>3. Right click on the <i>Recycle Bin</i> icon and select the <i>Empty Recycle Bin</i> option.</li> <li>4. Click on the <i>Yes</i> button to remove the files.</li> </ol>	<ol style="list-style-type: none"> <li>1. Select the files you want to remove.</li> <li>2. Hold <i>Shift</i> and press <i>Delete</i> on the keyboard.</li> <li>3. Click on the <i>Yes</i> button to permanently remove the files.</li> </ol>



### Take note

Do not delete any computer software files, as this could cause the computer to malfunction.



### Something to know

Files that are deleted from a flash drive *cannot* be restored from the *Recycle Bin*.



### Something to know

Previous versions are, at times, referred to as shadow copies.

## RESTORING FILES

If you cannot find a file on the computer, or you have deleted it by mistake, you can still recover the file by restoring it from the *Recycle Bin* to its previous version.



### Guided Activity 3.6

To restore files from the *Recycle Bin*, the following should be done:

1. Open the *Recycle Bin* by double-clicking on the icon that is usually found on the desktop.
2. Browse through the folder and select the file(s) or folder(s) that you need to restore.
3. Right click on the file or folder and from the *Action* menu, choose *Restore*.
4. The *Recycle Bin* will then restore the deleted file(s) or folder(s) to their original location.



### Activity 3.2

1. Which solution in Column B can be used to solve the problem in Column A? Note that more than one action can apply to a problem.

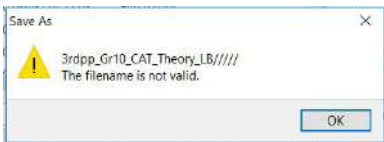
COLUMN A	COLUMN B
1. Struggling to find files on the computer	A. Save the file with another extension
2. 	B. Delete unnecessary files
3. File was copied as a shortcut	C. Name the most recent version of the file correctly
4. File was deleted by mistake	D. The wrong action is used; the user needs to use the correct shortcut key
5. User opens file, but Windows cannot open the file	E. Organise files into folders and sub-folders in a logical, hierarchical (tree) structure
6. User is using <i>Ctrl+C</i> on the keyboard to paste files into a new folder	F. Compress files
7. Lots of versions of the same file on the user's computer	G. Recover the file by restoring it from the <i>Recycle Bin</i> to its previous version
8. The wrong file name is used for a document; it needs to be Maths.docx but it appears as Jenny.docx	H. Keep file names short
9. There is a mix of Word files, video files, music files, PDFs, and text documents in the <i>Downloads</i> folder	I. Convert the file to .txt
	J. Avoid file characters
	K. Save the file as another file type
	L. Rename the file
	M. Organise files by their file type

... continued



### Activity 3.2

... continued

2. Identify the drive letter, folder, sub-folder, file name and extension in the file paths below. Make a copy of the table below in your workbook and fill in your answers under the correct heading in the table:

- a. c:\Games\Solitaire\Solitaire.exe
- b. e:\Music\Pop\Jenni – Roses.mp3
- c. c:\Program Files (x86)\Calculator.exe

#	DRIVE LETTER	FOLDER	SUB-FOLDER	FILE NAME	EXTENSION
a.					
b.					
c.					

Each file has a file extension identifying the type of file and how the computer should interpret it. A *.txt* file is a simple text document that contains words with no formatting. A *.doc* file allows for formatted text with different fonts and images.

This section will look at the following file types:

- Text files
- Document files
- Locked document files
- Web pages
- **Archives** and **compressed** files
- Presentation files
- Spreadsheet files
- Database files
- Image files
- Animation files
- Video files
- Audio files
- Adobe Acrobat

## TEXT FILES

There are two types of text files:

1. *.txt* (text)
2. *.rtf* (rich-text format)

Text files are files used to store plain text. Plain text refers to text that has no special formatting, such as fonts, font sizes, images and so on. In Microsoft Windows, text files are identified with the *.txt* file extension. Notepad is a popular application in Microsoft Windows that is used for opening and creating text files. Figure 3.14 shows an example of a *.txt* file:

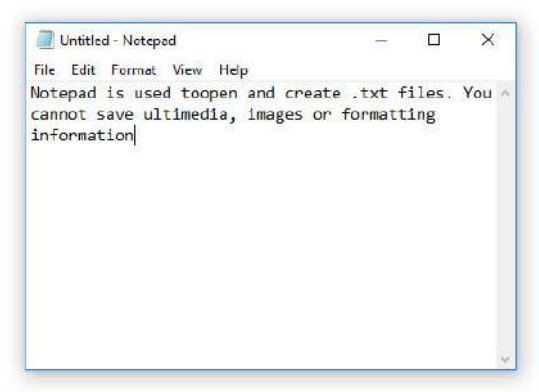
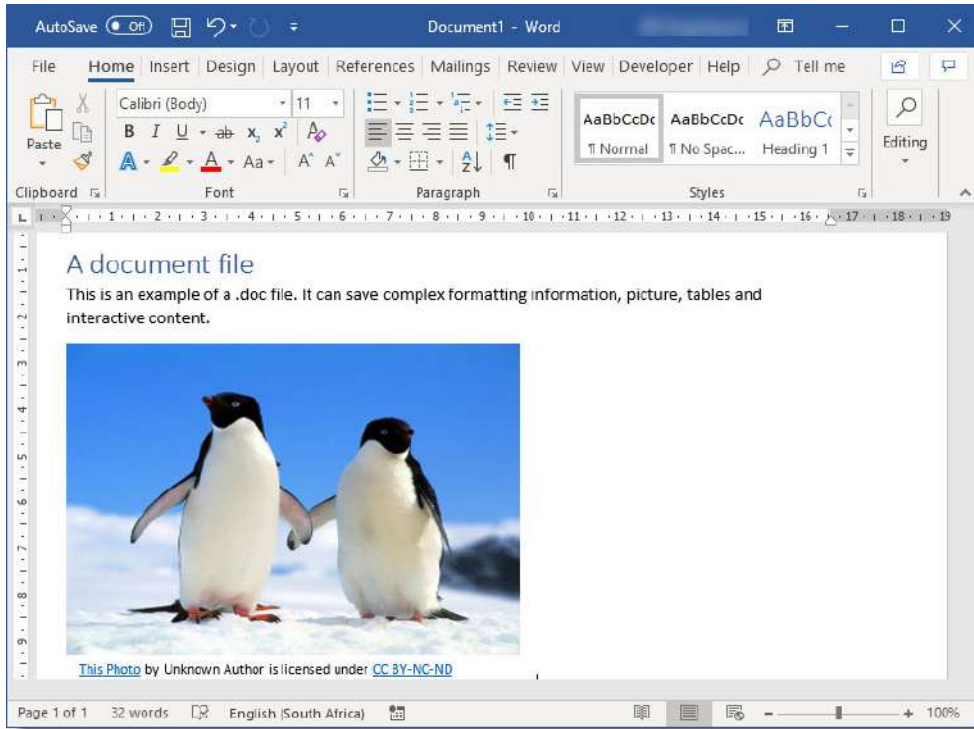

**Figure 3.14:** An example of a *.txt* file

**Rich-text format (RTF)** files can save more information than text files. This includes different font types, such as **BOLD**, *italic*, as well as font colour. RTF files cannot be opened in Microsoft Notepad, but can be opened in **Microsoft WordPad**. Both these applications are installed with Microsoft Windows for free.

## DOCUMENT FILES

Although document files (.doc, .docx and .odt) are used to store documents. It differs from text files and rich-text files because it can store more complex information such as custom formatting options and styles. Word processors – for example, Microsoft Word, Google Docs and LibreOffice – can be used to create and edit document files.



**Figure 3.15:** Document files can store text with advanced formatting

### DIFFERENT TYPES OF TEXT FILES

Jabulani is a Grade 12 learner who works almost every day on his computer on various school assignments. He recently learned that, although two different files may look the same when not formatted, for example a .txt file and a .doc file, the data actually differs. This means that he cannot just change the file type of one file to another and expect the document to open.

However, computer applications have improved quite significantly in that applications, such as Microsoft Word or LibreOffice, can convert one file type to another.

#### Example 3.1

To save the file in a different file format using the *Save As* function, Jabulani does the following:

1. By clicking on the *Save As* button, a dialogue box opens. This allows him to select the type of file he wants to save his file as, for example PDF, plain text, web page and so on. The application then makes sure that the raw data is saved in the correct way for that file format. An example of this dialogue box is shown in Figure 3.16 on the next page.

... continued

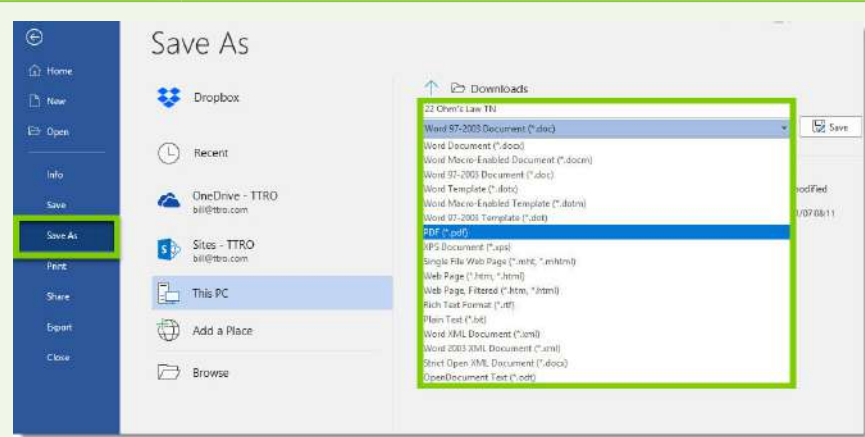

**Figure 3.16:** Save As allows you to select the file type you want to use

## LOCKED DOCUMENT FILES

**Locked documents** are documents with content that is difficult to change, or modify once it has been created. Locked documents are generally used in situations where you want to use the file in the format in which it was saved. Examples of locked document files would be contracts, formal letters and shop catalogues. The two most common locked document formats are the .pdf (portable document format) and .epub (E-PUB) file formats.

## WEB PAGES

A **web page** is a computer file that relates to websites and web servers. Web pages include information, such as the colours of text, backgrounds and images. It also includes links to images and other types of multimedia.

The two most common extensions for web pages are:

1. .html
2. .htm

The only difference between the two is that *.htm* is used as an alternate to *.html* by a few web servers that do not accept four-character extensions. Both extensions can be used on most web servers.

## ARCHIVES AND COMPRESSED FILES

Archives are types of files that can combine and compress multiple different files into one file. For example, if you need to send 50 files in an email to a group member, it will be much easier for you to combine and compress the files into a single *.zip* file, before sending the *.zip* file through email. This will make it so much easier for the other person to download the file. The *.zip* file will also be smaller since all the files are compressed into one file, making it easier to send and download. After receiving the files, it can be **decompressed** and accessed normally. The three main file extensions for archives are:

1. .zip
2. .rar
3. .7z

## PRESENTATION FILES

A presentation file stores information using slides that can be shown consecutively. Presentation files are used by teachers, businesses and learners where the speaker discusses the topic using the content of the slides. Slides are short, they can contain pictures and animations, and are generally attractive. The three main file extensions for presentations are:

1. .ppt
2. .pptx
3. .odp

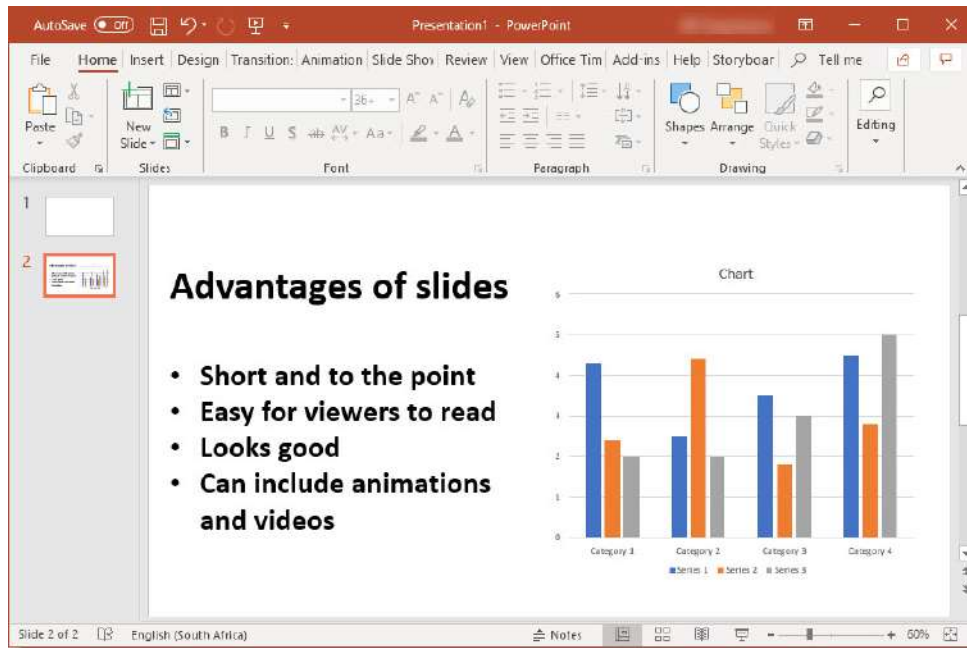

Figure 3.17: A slide in a presentation

## SPREADSHEET FILES

A spreadsheet file is a file that stores information in a large table. Companies use spreadsheets when they need to analyse large amounts of data, or do calculations. It is also used to show data, such as checklists and class lists. The three main file extensions for spreadsheets are:

1. .xls
2. .xlsx
3. .ods

The spreadsheet file gets its .xls (and .xlsx) extension from the most popular spreadsheet software – i.e. Microsoft Excel. Figure 3.18 is an example of someone's academic schedule.



### Something to know

Excel spreadsheets can have many sheets. Each sheet is a separate page that has its own data.

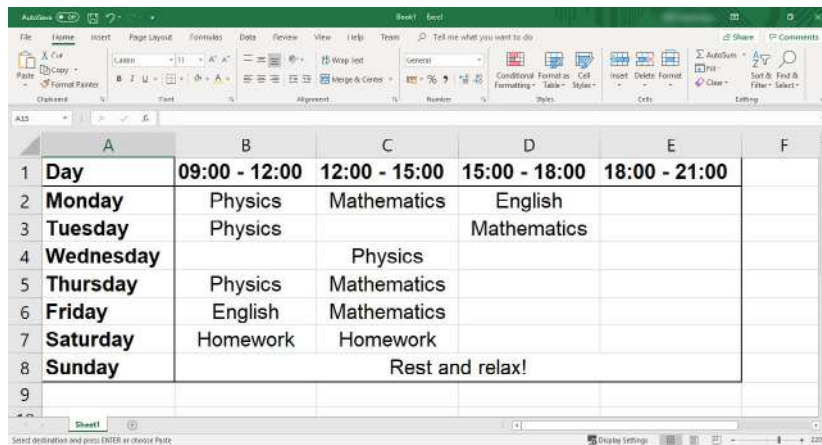

**Figure 3.18:** Spreadsheets show data in tables

## DATABASE FILES

Databases are similar to spreadsheets, except that the sheets, called *tables*, are all connected to each other. For example, your school might have a database for each grade with the full names of the learners, names of their parents, their contact details, addresses and the amount of school fees paid. Even though these items are listed in different tables, they are still linked together. Because of this, at the end of the month when the school needs to send out fee statements, the database software can create a statement where your name and surname, parents' contact details and fees owed are all displayed on the same page.

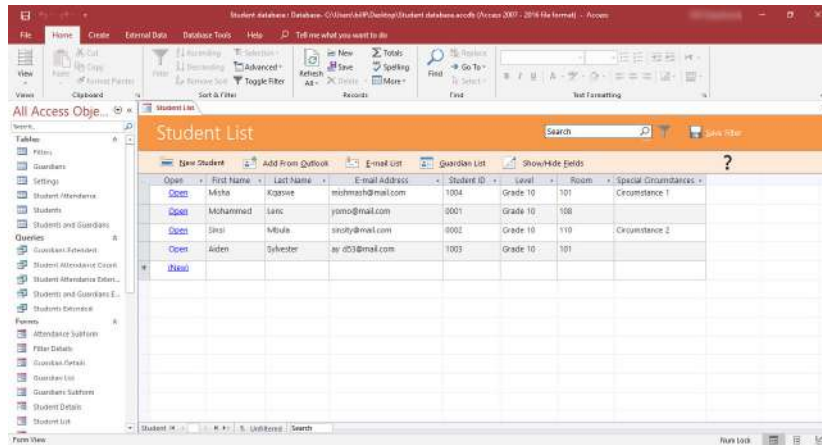

**Figure 3.19:** Databases can store related information in different tables

Most programmers use databases to store important data for their software.

## IMAGE FILES

There are five main formats used to store graphics:

1. .bmp (bitmap image)
2. .gif (**Graphics Interchange Format**)
3. .jpg or .jpeg (Joint Photographic Experts Group)
4. .png (portable network graphics)
5. .tiff (tagged image file format)

These image formats are used for cameras, scanning and printing. Most of these file formats need not be compressed and are, therefore, ideal for printing and web graphics. Photos taken by a camera, or pictures created using software, for example, Microsoft Paint or Adobe Photoshop, are often saved in one of these formats.

## ANIMATION FILES

**Animation files** are files that interpret moving images. The two most common animation file formats are:

1. .gif
2. .swf (Small Web Format Flash)

Although both these formats create animations, they do so in two different ways. GIF animations show normal GIF images one after another to create an animation; SWF files use programming to move shapes on the screen, creating an animation.

## VIDEO FILES

A **video file** format is used to store digital video data on a computer. Video file formats are usually compressed to reduce the file size. Video files are made up of a “**container**” and a “**codec**”. A codec is used to compress and decompress the video where the video files are too big, causing the video not to play, or be downloaded. Examples of codecs include *FFMpeg*, *DivX*, *XviD* and *x264*.

A container is a set of files that stores information about the digital file. For example, a container in a video file would be a combination of both audio and video in a single file so that the file can play both audio and video at the same time. Some common types of containers would be *AVI*, *FLV*, *WMV* and *MP4*.

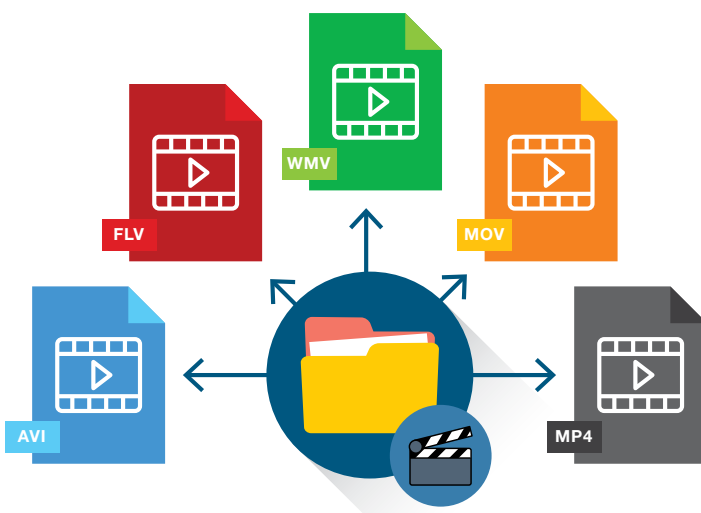

**Figure 3.20:** Different types of video file formats



### Something to know

The opportunity to create videos on PCs and mobile devices are endless. MP4 is one of the most common file formats used. It uses a separate compression for audio (m4a) and video (m4v), and is mainly used for sharing videos over the Web. MP4s are generally small in size; however, they have a high quality even after being compressed. MP4 files are popular, because they are compatible with both online and mobile **browsers**.

## SOUND FILES

Sound (audio) files are similar to video files, as they are compressed before they are stored on a computer. They are used to store audio files, such as music. Because of the popularity of using computers to store music and videos, the *.mpeg* and *.mp3* file types have become very popular in recent years. Common audio file formats consist of the following:

- *.aac* (Advanced Audio Coding)
- *.flac* (Free Lossless Audio Codec)
- *.mp3* (Moving Picture Experts Group Layer 3 audio)
- *.wma* (Microsoft Windows Media Audio).

## PORTABLE DOCUMENT FORMAT (PDF)

Adobe Acrobat is an application developed by Adobe Systems where you can view, create, print and manage files in a portable document format (PDF). PDFs are a very good file format for saving books, or published documents that can be easily sent to another user through email, etc.

## CONVERTING A DOCUMENT TO A PDF

You can convert a document to a PDF by doing the following:

1. Click on the file that you want to be converted into PDF format.
2. Click on the *File* tab and choose *Save As*.
3. Type in the file name.
4. Using the drop-down menu, click on the *PDF* under the *Save As* type.
5. Click *Save* and the document will be saved in a PDF format.



### Activity 3.3

1. Complete this activity by following these steps:
  - a. Create a sub-folder in *My Documents*. Name the new sub-folder: *CAT Grade10*.
  - b. Open the Word-processing application. Copy and paste any picture from the computer into the document.
  - c. Save the file with the file name: *Practice* in *My Documents*.
  - d. Move the *Practice.docx* to the folder: *CAT Grade10*
  - e. Create a PDF of the *Practice.docx* file. Save the file in the same location.
  - f. Rename the PDF file to *Practice\_new*.
  - g. Delete the file *Practice.docx* in the *CAT Grade10* folder.
2. Answer the following questions about the diagram below.



... continued



### Activity 3.3

... continued

- How many audio files are there?
- What type of file is "08.Internet and the world-wide"? What application can be used to open this file?
- "Image (16).png" can be opened with Adobe Acrobat Reader. Is this statement true? If not, provide the correct answer.
- What type of program can be used to open "4.3 Handover (171129) (Waiting for SME).pptx"?
- What is the name of the file that Excel can open up from the diagram above?

### REVISION ACTIVITY

- Each time Siphso saves a file, he saves it to the desktop of the computer. His desktop is very cluttered and he has trouble finding the files that he needs. Advise Siphso on a more effective way to organise his files. (4)
- Which of the following is NOT a file extension used for graphics files? (1)
  - .bmp
  - .gif
  - .toff
  - .jpeg
- Fred has created a folder called "Grade 10 PAT" on a school computer to save all his PAT files. He checks on the file properties and finds that the location of the folder is c:\users\fred\documents\Grade 10\Grade 10 PAT. Use the diagram to answer the questions below:

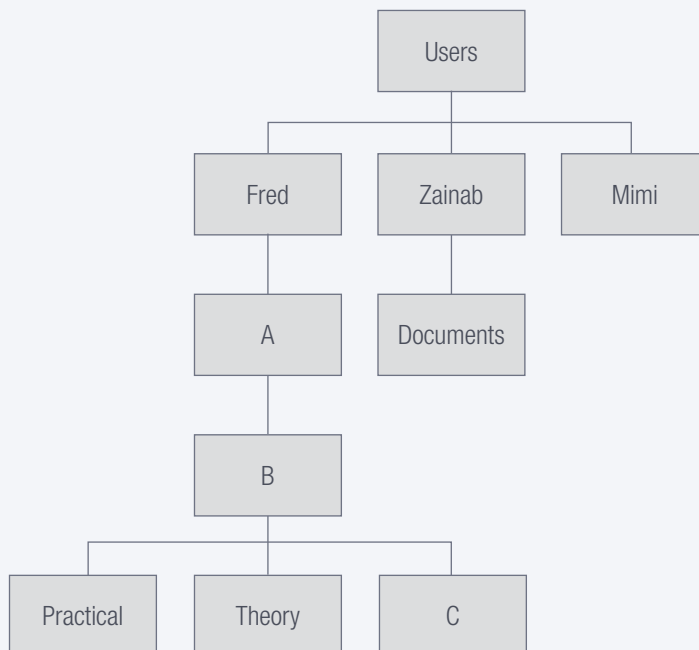

- Write down the folder names of folders A, B and C. (3)
- How many users have folders on this computer? (1)

... continued

## REVISION ACTIVITY

... continued

2. Match the file extension in Column A with the associated file type in column B. Write down only the letter of the file type (Column B) next to the number of the file extension (Column A), e.g. 1C.

(Note: It is possible that the application from Column B may be used more than once.)

COLUMN A	COLUMN B
1. doc	A. Web page
2. xlsx	B. Open Office presentation
3. zip	C. Audio file
4. html	D. Compressed file
	E. Microsoft Excel spreadsheet
	F. Microsoft Word document

(4)

3. Which shortcut key can you use to carry out the following actions?

- a. Rename a file (1)
- b. Copy a folder (1)
- c. Paste a document onto the desktop (1)

**TOTAL: [16]**

## AT THE END OF THE CHAPTER

Use the checklist to make sure that you worked through the following and that you understand it.

NO.	CAN YOU ...	YES	NO
1.	Explain the importance of file management.		
2.	Find a file path.		
3.	Find a file using a file path.		
4.	Distinguish between a file and a folder.		
5.	Explain the importance of using the correct file-naming conventions.		
6.	Organise, copy, rename, delete, restore, and move files and folders.		
7.	Search, view, and sort files and folders.		
8.	Describe the different file types and their extensions.		

# FILE AND PRINT MANAGEMENT

## CHAPTER OVERVIEW

Unit 4.1 File management skills

Unit 4.2 File compression

Unit 4.3 Print management

At the end of this chapter, you should be able to: 

- Create shortcuts.
- Use the Snipping Tool and Print Screen to take screenshots.
- Compress and decompress files and folders.
- Add new peripherals, such as a printer and mouse.
- Change the default printer.
- Explain what queue management is.
- Print files.

## INTRODUCTION

When you open an application using the menu system, it can sometimes be time consuming. An easy way to save time is to create a shortcut for an application or program that you use often. In this section, you will learn how to create **shortcuts**, take screenshots, as well as how to compress and decompress files.

Print management is the managing and monitoring of various print tasks. Before learning how to print, you will learn how to add a new peripheral device, as well as how to do basic printing and apply printer queue management.

## 4.1 File management skills

In this section, you will learn about basic computer management tasks that you need to do when working on a computer.

### CREATING SHORTCUTS

This section will look at how to create a shortcut on the desktop for your favourite program, application, or website, for easy access. There are different ways to create shortcuts and in this section, we will look at some of these ways.



#### Guided Activity 4.1

**Option 1:** If you want to create a desktop shortcut for your favourite program or file, do the following:

1. Right click on the `.exe` file.
2. Select *Send To*:
3. Click on *Desktop (create shortcut)* to create the shortcut.

A shortcut of this program will then be created on the Windows desktop.

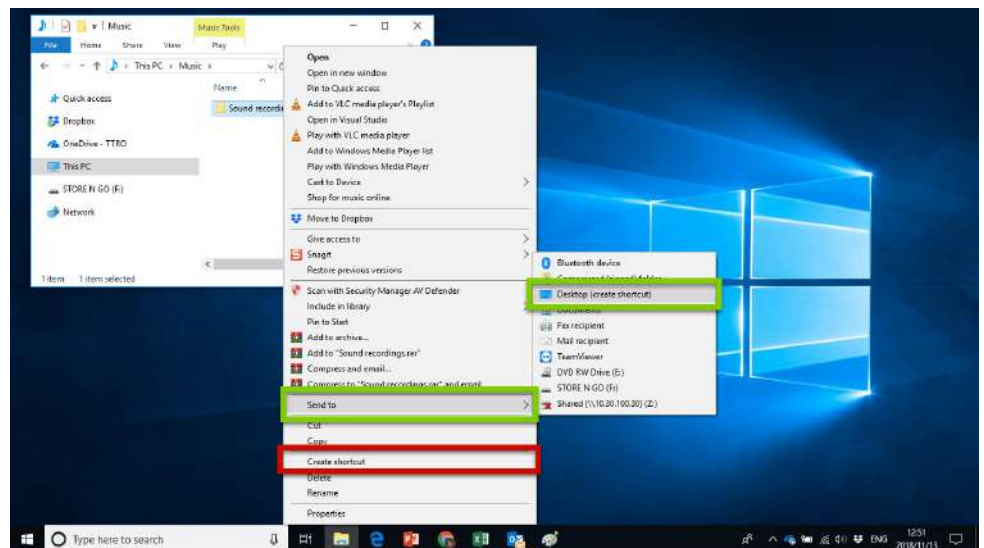

**Figure 4.1:** Creating a shortcut for a program

If you select *Create Shortcut* (indicated with the red rectangle), the shortcut will be created in the same location. In this example, the shortcut will be created in the *Music* folder.



## Guided Activity 4.2

**Option 2:** Another way of creating a shortcut would be to right click on the desktop, and then select *New* and then *Shortcut*.

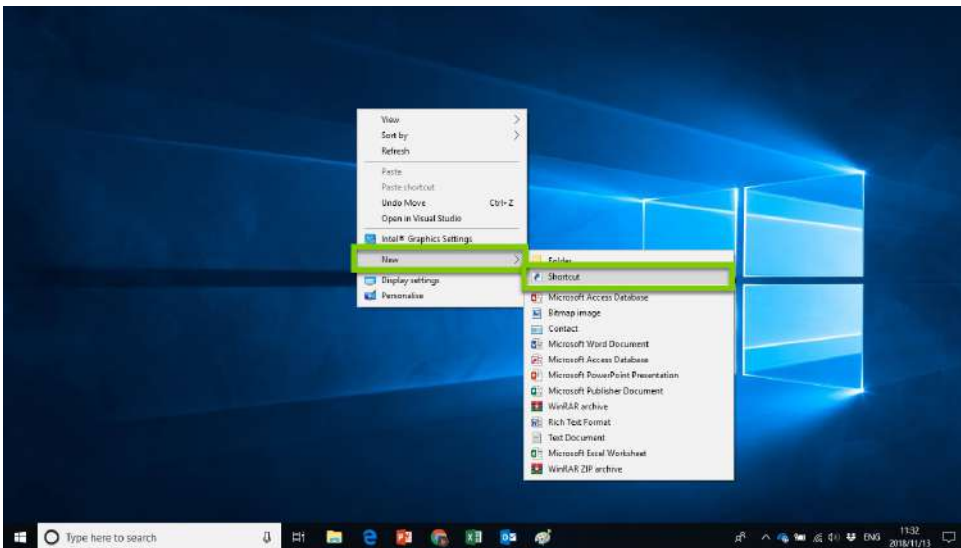

**Figure 4.2:** *Creating a shortcut on the desktop*

This will open the *Create Shortcut* wizard dialogue box.

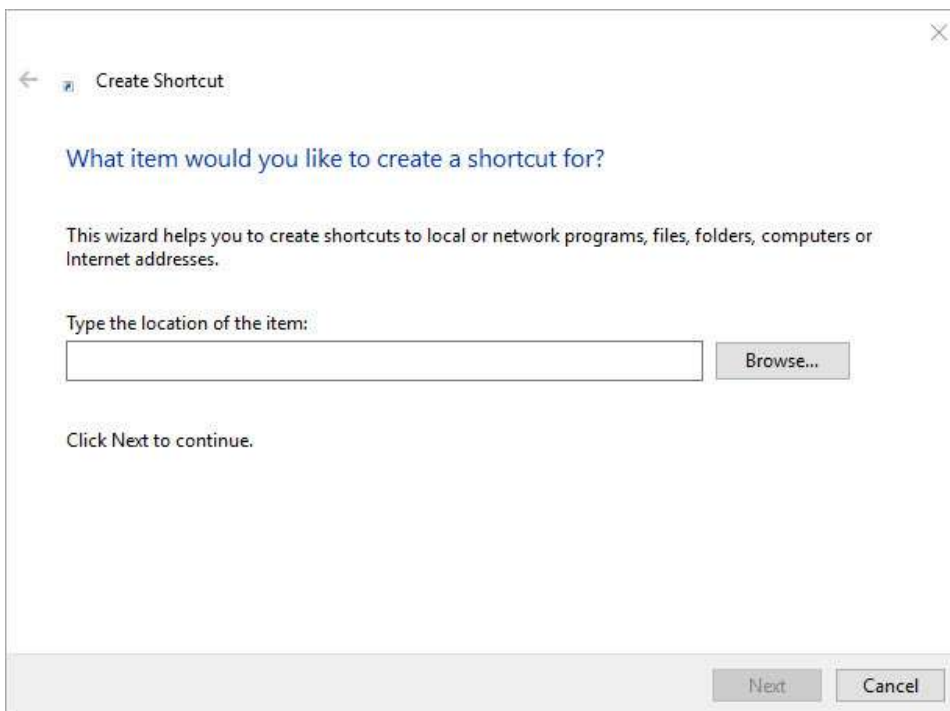

**Figure 4.3:** *Create Shortcut wizard dialogue box*

This **wizard** will help you to create a shortcut on the desktop.



### Something to know

This only works using the Google Chrome browser; not in Edge or Internet Explorer.



### Guided Activity 4.3

**Option 3:** Lastly, we will look at creating a shortcut for your favourite website. The method might differ for different operating systems. For this example, we will look at creating a shortcut for a website using the Google Chrome browser.

1. Open your favourite website or web page.
2. Click on the *Options* button on the top right-hand side of the web page, as seen in Figure 4.4:

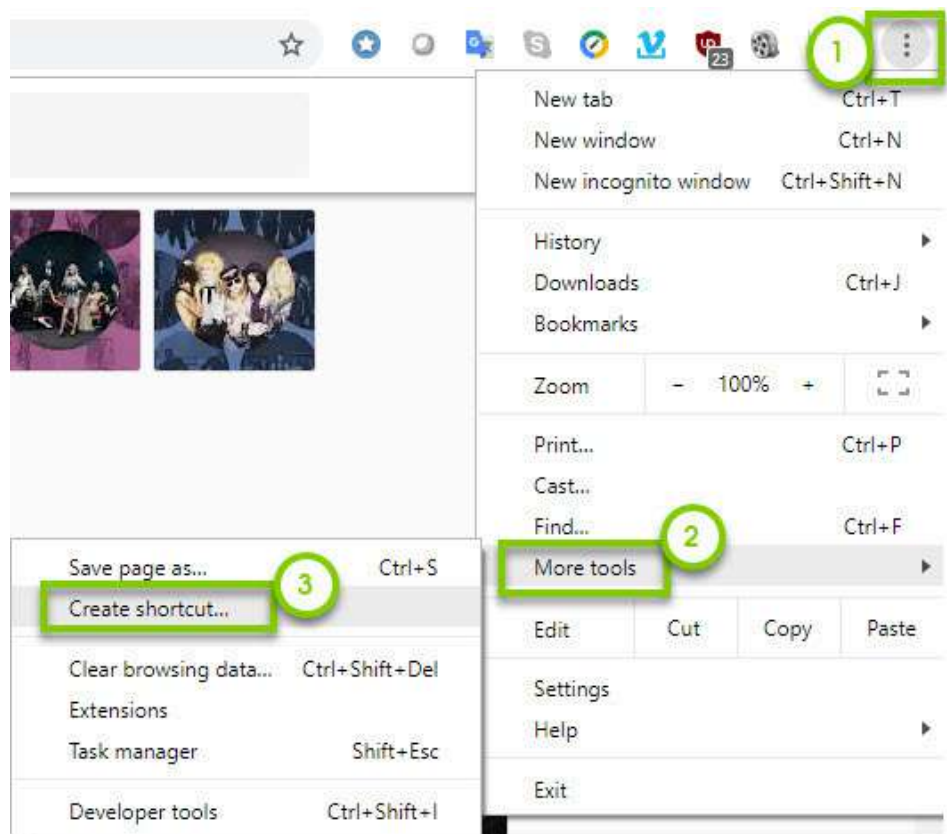

**Figure 4.4:** Web browser shortcut

3. Go to *More tools*, from the drop-down menu and choose *Create shortcut*. A dialogue box will appear asking you if you want to create the shortcut.
4. Click on *Create*, and the shortcut will be placed on the desktop.



### Something to know

Desktop shortcuts can save you time to find a specific file, folder, or even a website.

## TAKING SCREENSHOTS

A screenshot is an image of how the computer screen looks the moment you capture the screen. For example, it is a snapshot of whatever is displayed on the computer screen at that time.

Different models of computers have different shortcuts on how to take a screenshot. For most cases, you will press the *ALT* key and the *PrtSc* (print screen) key on the keyboard at the same time to take a screenshot of the selected window. *PrtSc* on its own takes a screenshot of the whole desktop.

This image is then saved to the clipboard. The clipboard is a memory space on the computer where data or graphics that are copied or cut are temporarily stored.



#### Guided Activity 4.4

To save the screenshot permanently, you can paste it into an application. In this example, the application is *Paint*. Do the following:

1. Open *Paint*.
2. Select *Edit* then *Paste* from the *menu* bar of the *Paint* window. An easier way to paste the screenshot will be to use the **hotkeys** (*Ctrl+V*) and the image will be pasted into *Paint*.
3. You can then save the screenshot by clicking *File* and then *Save As* from the *Paint* window's menu bar.
4. You can use the hotkeys (*Ctrl+S*) and save the file with the file name and file location you want, and then select *Save*.



#### Activity 4.1

1. Create a new folder on the computer. Name it *Practice*.
2. In the folder, create a shortcut to the following:
  - a. Favourite document in *My Documents* folder
  - b. Two of your favourite programs
3. Open the *Practice* folder. Take a screenshot with *Print Screen (PrtSc)* of what is displayed on the screen.
4. Paste the screenshot in *Paint*.
5. Save the image as *Practicescreen.jpeg*.
6. Move this image to the *Practice* folder.

Compressed files can be referred to as *archived* or *zipped* files and can contain many separate files in one large archive. This takes up much less space than the original files. Decompressing files is pretty much the opposite of compressing the files, which means to expand the archived or zipped folder back into its original form. In Windows, you can compress (zip) and decompress (unzip) files without installing any extra programs or applications. In this section, you will learn about compressing and decompressing files and folders.

## COMPRESSING AND DECOMPRESSING FILES AND FOLDERS



### Guided Activity 4.5

To compress files or folders using Microsoft Windows, you can do the following:

1. From the *Start* menu, open *This PC*.
2. Select all the files and folders you want to include in the compressed folder by holding down the *Ctrl* key while clicking on each file.
3. Right click on the selected items and from the drop-down menu, choose *Send To*. Then select the *Compressed (zipped) folder* option. This will create a zipped file, in the same location, in which the files are located. The file extension for compressed folders is *.zip*.
4. Finally, enter a name for the compressed folder.

### Something to know

By default, the new *.zip* file will have the same name as the file or folder that you compressed. However, if you compress multiple files and folders, the name of the *.zip* file will be the same as the first file that you clicked at the start of the compression.

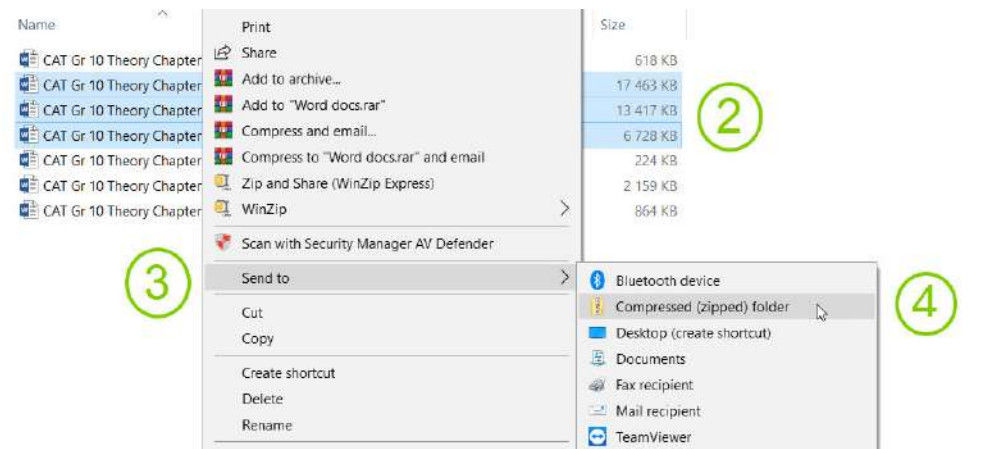

Figure 4.5: Compressing a folder

## DECOMPRESSING FILES OR FOLDERS



### Guided Activity 4.6

To decompress files or folders using Microsoft Windows, you can do the following:

1. From the *Start* menu, open *This PC*.
2. Look for the *.zip* file that you want to decompress, right click on it and choose *Extract Files...* A dialogue box will open. You should choose the destination for the decompressed files.
3. Click on *New Folder*.
4. Name the folder.
5. Click *Ok*. The files will be extracted to the folder that you created.

File compression has the following multiple advantages:

- Compressed files require less storage space. This allows you to fit more files onto storage devices.
- Because the files use less storage space, it can be transferred more easily and quickly between storage devices. This is especially true when the files need to be transferred over the internet.
- Because many files can be stored in one archive, it is easier to transfer the data and to ensure that the recipient gets all the correct files.

However, compressed files also have some disadvantages, with the most notable being:

- Some compressed files need specific software to decompress them. Fortunately, Windows 10 can decompress *.zip* files without requiring any additional software.
- Compressing and decompressing files can take a bit of time, depending on the level of compression and the size of the files that need to be compressed.



### Activity 4.2

1. When sending a file as an email attachment, the email program cannot attach the file to the email. The following message is shown, but you do not want to send it using Google Drive.

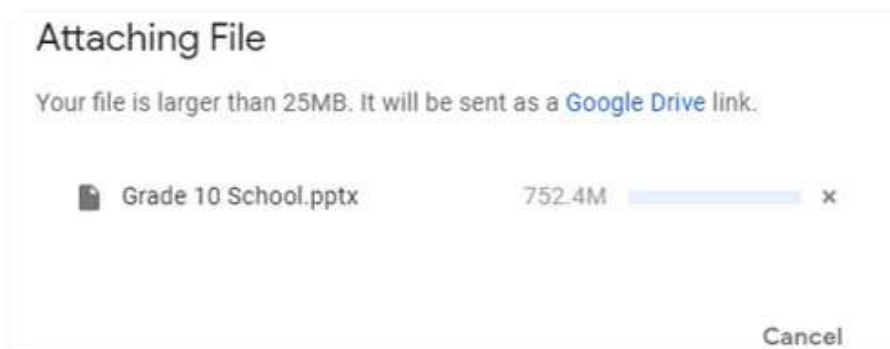

- a. Briefly explain how you can use an email to send a file as an attachment, even though it is such a large file.
- b. What is the file extension of the answer in (a)?
- c. After sending the file to the recipient, how does the recipient have access to the file?



### Something to know

When zipping or unzipping files or folders, the original files or folders are never deleted. If you need to delete these items, you will have to do it manually.



### EXTRACTING ZIP FILES



<https://www.youtube.com/watch?v=nXAYWwiDvc8>

## 4.3 Print management

Print management allows you to install, view and manage printers. Print management is managing and monitoring various print tasks. Many software companies have proper print management software that coordinates all the print jobs that need to take place.

### ADDING A NEW PERIPHERAL

Some printers have software that must be installed before it is connected to the computer. Always read the instructions that come with the printer to see if this is the case. However, in most cases, you can connect printers immediately.



#### Guided Activity 4.7

To install a new printer, do the following:

1. Connect the printer to the computer, turn it on and turn the computer on.
2. Click *Start* and look for *Control Panel > Devices and Printers > Add Printer*, and then choose the type of printer that you are installing.
3. This opens the *Add Printer* wizard, which will guide you on how to add the printer.

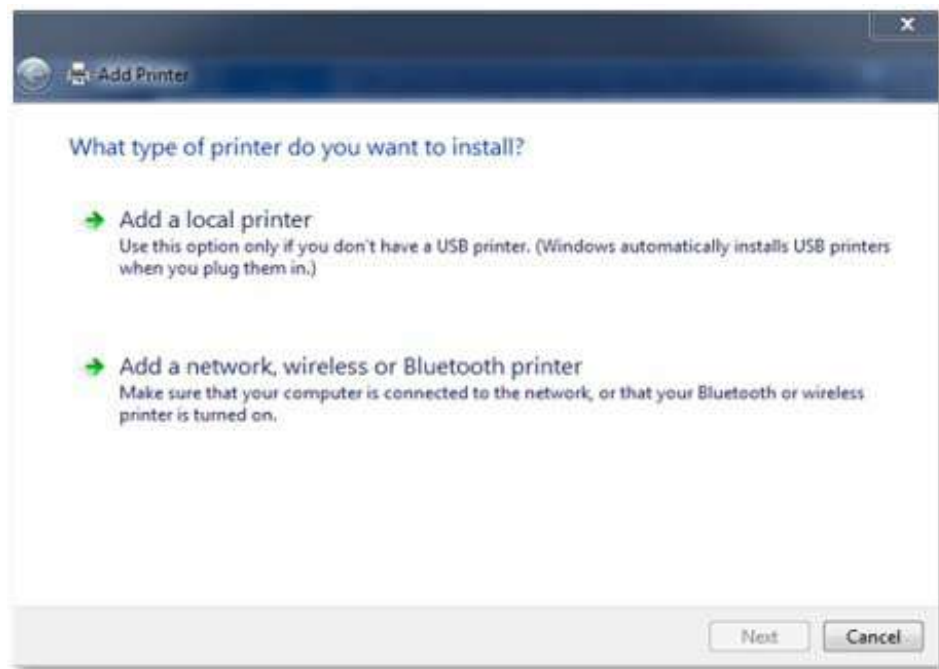

**Figure 4.6:** Adding a new printer wizard



#### Guided Activity 4.8

To add a mouse,

1. Click on *Start > Devices and Printers > Add a Device*. The *Add a Device* window will open.
2. The window will show you a list of devices that are available to connect.
3. Click on the device that you want to connect to (in this case, the mouse).
4. Click *Next* and follow the instructions.

## CHANGING THE DEFAULT PRINTER

If you already have a printer added to your computer, this printer will always be used as the default printer. However, if you have more than one printer installed on the computer, you can change the default printer.



### Guided Activity 4.9

To change a default printer, you can do the following:

1. Click on *Start*.
2. Click on *Control Panel* and choose *Devices and Printers*.
3. Right click on the printer you want and from the drop-down menu, select the *Set as default printer*.

After you have done this, the default printer will have a tick next to it to indicate that this is the current default printer.

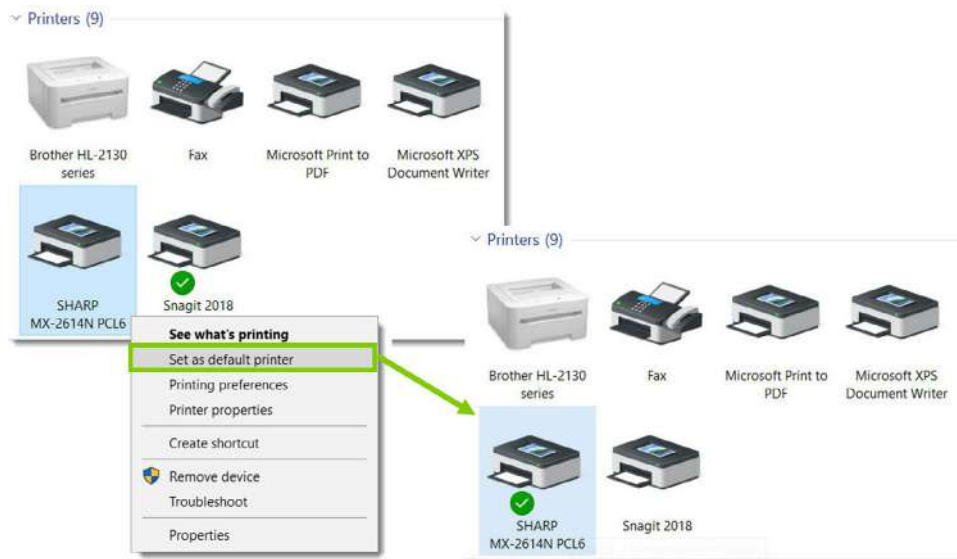

Figure 4.7: Changing the default printer

## BASIC PRINTING

If you need to print a document or image, you can do so in the following way.



### Guided Activity 4.10

1. Select the document or image that you want to print.
2. Right click on the file and choose *Print*.
3. If a dialogue box appears, click *OK*, or the *Print* button.

The computer will immediately send the pages to the printer, which should start printing the pages automatically.



### Something to know

To print a number of documents one after the other, select all the items, then right click on the selected items and choose *Print*. The documents will be printed in the order in which they were selected.

## PRINTER QUEUE MANAGEMENT

When a printer needs to print more than one document, it is placed in a queue and printed according to the sequence that it was selected.



### Guided Activity 4.11

To check what you are printing:

1. Click on *Start*.
2. Select *Control Panel > Devices and Printers*.
3. Double-click on the *Default Printer*.

The *Printer* window will open and this will show in the order in which the documents will be printed.

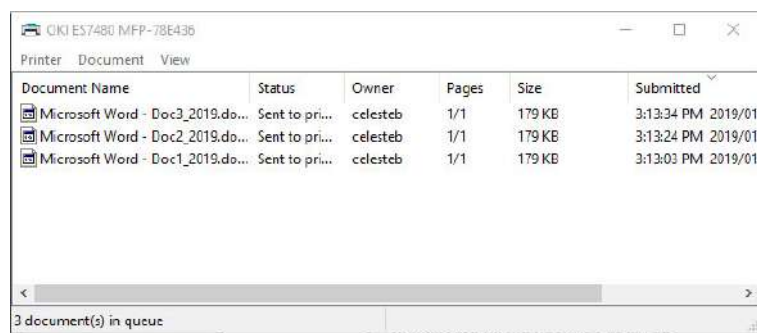

Figure 4.8: Files in printer queue



### Activity 4.3

Mimi has her own business and wants to buy a new printer, which she needs to connect to her desktop. She is going to use her printer to print quotations and invoices for her clients. She also needs to connect the printer to the desktop in the office.

1. Should Mimi buy a laser or an ink tank printer? Motivate your answer. Consider the cost of the printer, as well as the printing cost.
2. Mimi's focus is on the quality of the print-outs rather than cost. Which printer should she buy?
3. After she has bought her printer, briefly explain to Mimi how she should connect this printer to the desktop.
4. Explain why nothing is printing after Mimi has connected the printer to the desktop.

### REVISION ACTIVITY

1. The following icon appears on the desktop of a computer:



2.
  - a. How can you tell that the icon is a shortcut? (1)
  - b. What is the benefit of using a shortcut to an application? (1)
  - c. How would you launch the application using the shortcut? (1)
  - d. What is the name of the application to which the shortcut refers? (1)

... continued

## REVISION ACTIVITY

... continued

3. a. What is the name of the Windows 10 tool that can be used to create a screenshot? (1)
- b. What is the difference between pressing *PrtSc* and pressing *Alt* together with *PrtSc* (*Alt + PrtSc*)? (2)
4. The screenshot below shows the printers that are installed on Thalia's computer.



- a. What is the name of the default printer? (1)
- b. Describe briefly how you would make it the default printer. (2)
5. The screenshot below shows a list of documents waiting to be printed.

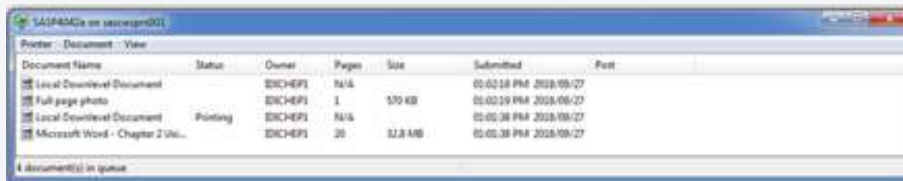

- a. What is the name given to this list of documents? (1)
- b. You have decided that you no longer want to print the Microsoft Word document. Describe briefly how you would remove this document from the list. (2)
- c. You need special paper to print the full-page photo. You are only able to purchase the special paper the next day. Describe briefly what you would do to temporarily prevent the photo from printing. (2)
6. Samiya, a Grade 10 learner, has a folder called *Grade 9*, which is taking up a lot of space on her computer. How could she reduce the amount of space the folder takes up without deleting any of the files inside the folder? (2)

**TOTAL: [17]**

## AT THE END OF THE CHAPTER

Use the checklist to make sure that you worked through the following and that you understand it.

NO.	CAN YOU ...	YES	NO
1.	Create different types of shortcuts.		
2.	Take screenshots.		
3.	Compress and decompress files and folders.		
4.	Add a new printer and mouse.		
5.	Change the default printer.		
6.	Describe what queue management is.		
7.	Print a file.		

# HARDWARE

## CHAPTER OVERVIEW

- |          |                   |
|----------|-------------------|
| Unit 5.1 | What is hardware? |
| Unit 5.2 | Input devices     |
| Unit 5.3 | Output devices    |
| Unit 5.4 | Storage devices   |
| Unit 5.5 | Green computing   |

At the end of this chapter, you should be able to:

- Define and describe what hardware is.
- List the various types of ports and connectors.
- Define input.
- Discuss the types of input.
- Discuss the common input devices used.
- Define output.
- Identify the different types of output.
- Discuss the common output devices used.
- Define storage.
- Identify the different storage devices used.
- Use different methods to connect peripherals.
- Understand the importance of green computing and recycling.

## INTRODUCTION

Have you ever wondered what we would do without computers in this day and age? Pretty much everything in this world works with computers; from using an ATM, to buying groceries and making new friends. We live in a world where, after you have bought a new computer, taken it home and, before even unpacking it, there is an advertisement for a new computer that makes yours now outdated.

According to Moore's law (1970), computer processor speeds will double every two years. For this to happen, a computer's components must be improved on a continuous basis.

Looking back to where computers started, you will realise that it was not at all as complex or technologically advanced, such as the ones we have today. In the early 1600s to 1800s, people started thinking of building a device that could solve complex problems and calculations easier and faster than what they could do manually. They wanted a device that could add and subtract. As a result, the first digital calculator that could add and subtract was built by the 18-year-old Blaise Pascal in 1642.

As the years went by, newer and better calculators and computers were built. One of the first complex machines that forms an important part of the computer history, was the ENIAC, built for the US army between 1943 and 1946. It was a very big computer that could do thousands of calculations.

After that, computers started changing the world more and more as it became smaller, faster and smarter.

# 5.1 What is hardware?



## HARDWARE BASICS

Have a look at this video to see a 3D virtual tour of hardware:



[https://www.youtube.com/watch?v=vG\\_qmtdBPTU](https://www.youtube.com/watch?v=vG_qmtdBPTU)

A computer consists of two major parts – i.e. hardware and software.

Hardware refers to all the physical parts or components of a computer, such as the monitor, keyboard, computer data storage, graphics card, sound card and motherboard. Software refers to the instructions that can be stored and run by hardware.

There are many different kinds of hardware that can be installed inside, or connected to the outside of a computer. To make it easier for you to understand, we will divide it into the following categories:

- Input devices
- Output devices
- Storage devices

## PORTS AND CONNECTORS

**Ports** and **connectors** form an important part of a computer. Ports allow computers to connect with different types of hardware, such as a keyboard, mouse or monitor. Many devices use cables to connect to the computer. Devices can also be connected using Wi-Fi (**wireless**), or **Bluetooth** (short-range wireless).

The connector (plug) which is found at the end of a cable fits into a specific port (socket) of the computer. These ports are usually found at the back of the computer.













**Figure 5.1:** Port (1) and connector (2)

**Table 5.1:** Types of ports, common connectors and examples

PORT	IMAGE OF PORT	CONNECTOR	USES
USB port			Used to connect many devices, such as smartphones, flash drives and external hard drives
VGA port			Used to connect monitors and data projectors

... continued

PORT	IMAGE OF PORT	CONNECTOR	USES
DVI port			Used to connect display devices, such as monitors
HDMI port			Used to connect monitors, data projectors and gaming consoles
3.5 mm port			Used to connect audio devices, such as speakers, head phones and microphones
Ethernet			Used to connect to a network device, such as a switch or router
RJ-11			Used to connect an internet router to a telephone line

## ADAPTERS AND CONVERTORS

Almost every peripheral device uses an adapter to communicate with a computer. With new technology, the type of computer ports and other computing devices change. However, instead of buying a new computing device, you can use an adaptor convertor to provide additional compatibility and functionality.

Types of common adaptors include the following:

- HDMI to VGA
- HDMI to DVI



### Activity 5.1

1. Define the concept *hardware*.
2. Match the port in Column A with the correct device in Column B.

COLUMN A	COLUMN B
1. USB Port	A. Smartphone
2. USB Type C	B. Flash disks, keyboard and mouse
3. VGA Port	C. Network switch
4. HDMI cable	D. Monitor
5. Ethernet cable	E. Laptops and television

3. Briefly explain when adaptors are used.

Input devices are hardware devices that allow you to enter data into the computer, or interact with the computer.



Remember, when entering data, you are actually giving the computer an instruction to do something. In this section, you will learn about the different types of commonly used input devices.

## COMMON INPUT DEVICES

### KEYBOARD

A keyboard is used for entering information into a computer, such as letters, words, numbers and symbols. Pressing any key on the keyboard is an input that the computer uses as data. There are different types of keyboards, as shown in the table below.

**Table 5.2:** *Different types of keyboards*

TYPE OF KEYBOARD	IMAGE
Standard keyboard (external)	
Laptop keyboard (built-in)	
Ergonomic keyboard	
Gaming keyboard	

... continued

TYPE OF KEYBOARD	IMAGE
Foldable keyboard	
Laser keyboard	



### Something to know

The concept of pressing a key to type text has been around for a very long time. One of the early inventions, which later became the typewriter, was invented by Pellegrino Turri for his blind girlfriend so that she could write letters to him.



### Something to know

The *Oxford Dictionary* acknowledges both “computer mice” and “computer mouses” as the correct plural forms of the term. For the purpose of this book, however, we will be using the plural form “mice”.

## POINTING DEVICES



Pointing devices are used to control the movement of the **cursor** on the screen. The major pointing device is the mouse for the desktop computer and the touchpad for the laptop.

### MOUSE

The mouse is the second most important input device of a computer. Using the mouse, you can move the mouse pointer or cursor on the computer screen, allowing you to interact with the computer.

There are different types of mice, as shown in the following table.

**Table 5.3:** *Different types of mice*

TYPE OF POINTING DEVICE	DESCRIPTION OF MOUSE	IMAGE
Wireless mouse	A mouse that connects to a computer using Wi-Fi or Bluetooth	
Cable mouse	A cable mouse uses a USB connector to connect to the computer or laptop	

## FIRST COMPUTER MOUSE

Douglas Engelbart invented the first computer mouse in 1963. The mouse had two wheels positioned at a 90-degree angle to each other to keep track of the movement. The ball mouse was only invented in 1972 and the optical mouse, around 1980.

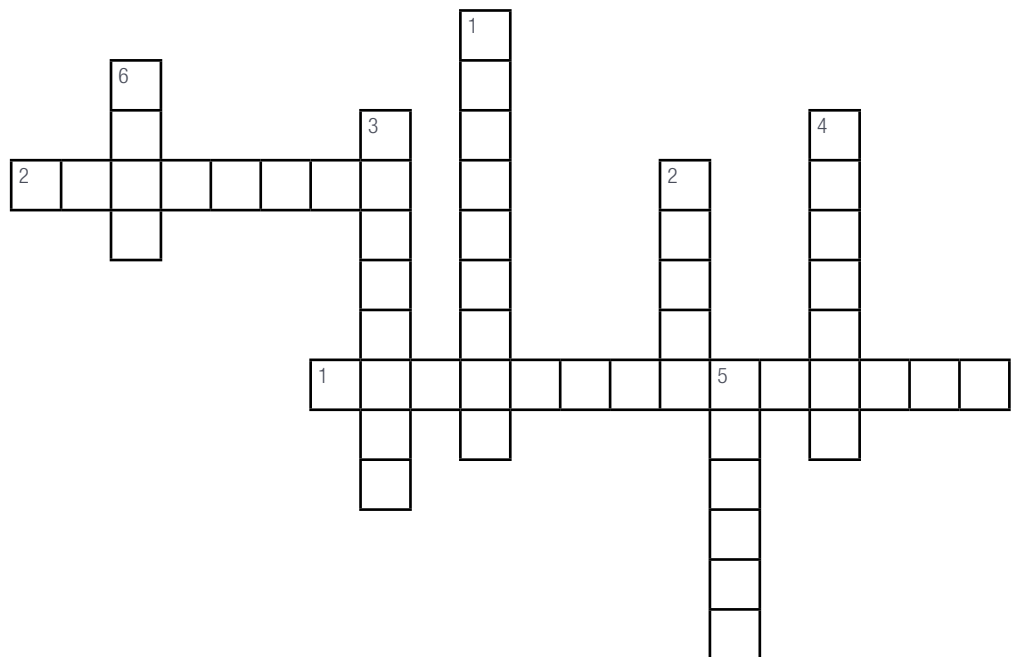

**Figure 5.2:** Engelbart's mouse



### Activity 5.2

1. Fill in the following crossword puzzle using the clues that are provided.



#### Across

1. A type of wireless technology mice used
2. Physical component of a computer like a mouse

#### Down

1. Which type of keyboard is used to minimise muscle strain
2. Used to move the pointer on a screen
3. For entering information, such as letters, words, numbers and symbols into the computer
4. Controls movement of the cursor
5. The standard keyboard
6. This allows computers to connect with different types of hardware, such as a keyboard, mouse or monitor

Output devices receive data from a computer. The output device converts this data to a display, projected image, or print-out.

## COMMON OUTPUT DEVICES

### MONITORS

A monitor, also known as a visual display unit (VDU), is the main output device of a computer, as it represents data in a visual form.



**Figure 5.3:** An example of an LCD monitor

The size of a monitor is measured in inches diagonally from one corner to the other.

Another important aspect of a monitor is its resolution. The clarity of text and images displayed on the monitor depends on the screen resolution. Screen resolution is measured in **pixels** (which is short for *picture element*). A pixel is a tiny dot of colour displayed on a monitor. The more pixels there are, the more detailed the picture will look. The screen resolution shows you how many pixels the screen can show horizontally and vertically. It is written as 1 280 × 800, which means that the screen can show 1 280 pixels horizontally and 800 pixels vertically.

A third important characteristic is the refresh rate of a monitor. This can be defined as how quickly the image on the monitor can be updated with the newest information.

### PRINTERS

Printers allow a computer to convert electronic data (soft copy) into a hard copy (i.e. printed out on a piece of paper). Printers are generally used to print large amounts of text and documents, and can also be used to print graphics, such as photos.

For the purpose of this book, we will only look at the following four printers:

1. **Inkjet printer:** This is a very popular printer that can combine black, white and colour printing, all at the same time. These printers operate by using cartridges that contain the ink. When the print job starts, the ink heats up and flows through a set of tiny holes. The heating process results in a small droplet of ink forming, which is then released as a single dot, forming a part of the image or text. This happens continuously until the whole image or text has been completed. This is why inkjet print-outs are



#### Something to know

An inch is about 2.5 cm; therefore, a 22-inch monitor has a diagonal length of  $22 \times 2.5 \text{ cm} = 55 \text{ cm}$ .



#### Something to know

The resolution of a monitor is measured in PPI (pixels per inch).

sometimes still a bit wet. This type of printer can be seen in Figure 5.4 and are commonly used in homes.

- Ink tank printer:** An ink tank printer uses the same technology as an inkjet printer to print documents. The difference is that an inkjet printer's ink cartridges are replaced with ink tanks, which hold a much larger volume of ink (up to 70 ml). The ink tanks can be filled by the user when they are empty. Each colour is stored in a separate tank and only the colour that is used up, has to be refilled. Ink tank printers can print 1 000 pages or more. Ink tank printers are suitable for printing documents where a large number of copies are required.



**Figure 5.4:** Inkjet printer

- Laser printer:** This is a common printer used in the workplace. It can print a lot of sheets quickly and with high quality. A laser printer works by directing a laser beam onto a drum, which forms a mirror image of what has to be printed. This causes parts of the drum to be magnetised. When the drum rotates, it picks up the ink powder, called *toner*. The toner is then transferred to the paper, printing the letters or images on it with a hot roller bonding the toner to the paper. An example of this printer can be seen in Figure 5.5.
- 3D printer:** 3D printing is the process of making a three-dimensional (3D) solid model from a digital file. It works by transforming a digital file into a 3D model by adding one layer of material at a time.



**Figure 5.5:** Laser printer



**Figure 5.6:** 3D Printer

Print resolution is measured in dots per inch (DPI). This is similar to the way pixels work on a computer. The printer settings can be adjusted to increase or decrease the DPI. The higher the DPI, the more dots there are, resulting in a high-quality print-out.



#### INKJET PRINTER VERSUS LASER PRINTER



<https://www.youtube.com/watch?v=x4lgj5zkB9U>

The following table shows the comparison between various kinds of printers.

**Table 5.4:** Advantages and disadvantages of different printers

TYPE OF PRINTER	ADVANTAGES	DISADVANTAGES
Inkjet	<ul style="list-style-type: none"> <li>Portability: These printers are quite small in comparison to other printers and are, therefore, easy to move from one place to another (portable).</li> <li>Cost: The initial cost of buying the printer is low.</li> <li>Page cost: Cost per page is lower than the laser type.</li> <li>Space: Compared to a laser printer, an inkjet printer takes very little space on a desk.</li> </ul>	<ul style="list-style-type: none"> <li>Cost: Although the initial cost of the printer is affordable, the ink cartridges are quite expensive.</li> <li>Speed: These printers are slow and are not suitable for high volumes of printing.</li> <li>Quality: Copies might be slightly wet after the print job and might require time to dry.</li> </ul>
Ink tank printer	<ul style="list-style-type: none"> <li>Portability: These printers are comparable in size to inkjet printers and can easily be moved from one place to another.</li> <li>Cost: The cost of refilling ink tanks is cheaper than replacing an ink cartridge.</li> <li>Page cost: Cost per page will be lower than an inkjet printer.</li> </ul>	<ul style="list-style-type: none"> <li>Cost: The initial cost is more than that of an inkjet printer, but comparable to that of a colour laser printer.</li> <li>Speed: Comparable to an inkjet printer, but can be used for high-volume printing.</li> </ul>
Laser	<ul style="list-style-type: none"> <li>Quality: Has high-quality print-outs.</li> <li>Speed: It can print more pages at the same time than the inkjet.</li> <li>Cost: Replacing toner in this type of printer is cheaper than inkjet printers.</li> <li>Noise: This type of printer hardly makes any noise.</li> </ul>	<ul style="list-style-type: none"> <li>Cost: A laser printer is more expensive than an inkjet printer.</li> <li>Space: Laser printers are much bigger and heavier than inkjet printers. It therefore takes more space.</li> <li>Maintenance: Servicing or fixing can be quite costly.</li> </ul>
3D	<ul style="list-style-type: none"> <li>Speed: Speed of the parts of a design can be produced much quicker than normal manufacturing methods.</li> <li>Labour cost: One of the main advantages of 3D printers is the low cost of labour.</li> <li>Customisation: 3D printers allow complete freedom for customising designs.</li> </ul>	<ul style="list-style-type: none"> <li>Quality: The quality of a part is not as efficient as manufacturing a part.</li> <li>Expensive: 3D printing equipment and material costs are expensive.</li> <li>Material: At the moment, the type of materials that can be used in 3D printers is mainly plastic.</li> <li>Emissions: 3D printers in homes can produce toxic emissions.</li> </ul>

 **Activity 5.3**

Lesedi's dad got an inkjet printer for the house; however, it is not working and no printing is taking place. It seems that there is no communication between the printer and the computer.

Answer the following questions regarding the scenario:

1. Which connector do printers usually have?
2. Briefly explain why a printer is an output device.
3. List two advantages and two disadvantages of the printer that Lesedi's dad bought.
4. Explain one possible reason why the printer and computer are not communicating.



## Something to know

There is a difference between *storage media* and a *storage device*. *Storage media* is anything that holds information. It refers to the digital medium that is used in the storage devices, for example magnetic disks, cards, barcodes, etc. A *storage device* is a device that uses the storage medium and provides a physical interface, such as a CD/DVD player, an external hard drive, a USB flash drive, etc.

Storage devices are used to store data. There are a variety of storage devices with differences in storage capacity, speed, portability, as well as functions. In this section, you will learn about the different types of storage devices and how they are used – i.e. how much data needs to be stored, how quickly the data needs to be transferred and how portable the storage needs to be.

## CONCEPTS USED IN STORAGE CAPACITY

Before we discuss storage devices in great detail, let's quickly look at the different capacities storage devices can have.

Data on computers is stored as numbers, which consist of only 0s and 1s. Computer memory is made up of electronic components, which can either be on (1), or off (0). The smallest unit of data storage (0 or 1) is called a **bit**. A number made up of eight bits (11111111) is called a byte.

**Table 5.5:** *Measuring capacity*

CAPACITY	DESCRIPTION
Kilobytes (Kb)	This is defined as 1 024 bytes. A normal word document is usually about 100 kilobytes.
Megabytes (Mb)	This is defined as a 1 024 Kb. Programs, videos and music are examples of media that are measured in Mb. An average music file would be about 6 Mb.
Gigabyte (Gb)	This is defined as approximately 1 024 Mb. In 1988, a computer had a 30 Mb hard drive. Now, the hard drive of the average computer has about 400 Gb of storage space.
Terabyte (Tb)	One TB is approximately 1 024 Gb. External hard drives and modern computers have at least 1 Tb of storage available.

## COMMON STORAGE DEVICES





Nowadays, we are used to hundreds of gigabytes of storage capacity in our computers. With looking at storage devices, there are three main things to remember:

- Storage capacity:** This determines how much data can be stored on the device.
- Storage speed:** This determines how quickly new information can be written to the device.
- Reliability:** This determines the likelihood of the device breaking down.

We will look at the following storage devices:

- Internal hard drive (**fixed**)
- External hard drive (portable)
- SD card
- Solid-state drive (SSD)**
- Flash drive

**Table 5.6:** Types of common storage devices

STORAGE DEVICE	DESCRIPTION	USES	IMAGE
Internal hard drive	Internal hard drives are found inside computer systems. Hard drives are not really used to transfer data between computers, or even to people. This is because most hard drives are fitted in the computer case and this is usually done with screws, which makes it difficult to move.  Modern hard drives can have up to 12 Tb of storage space.	Hard drives are the main storage device in computers because of their high speed and high storage capacity. It is used to store data in the form of images, music, documents and videos.	
External hard drive	External (or portable) hard drives are <b>non-volatile</b> hard drives that are generally used outside the computer case and can be attached to the computer through a USB connection or wirelessly.	It is quick to connect to other computers and is really good in transferring files from computer to computer.	
SD card	SD cards, especially microSD cards are small storage devices that can have a storage capacity of up to 512 Gb.	Due to their small size, SD cards are often used in portable devices, such as smartphones and cameras to provide extra storage capacity.	
SSD	Solid-state drives (SSDs) are a type of internal hard drive that does not contain any moving parts, such as internal hard drives. It is quite similar to a CPU that has many small transistors, with each transistor storing one bit of data. Because of this, it has a much lower storage capacity and much higher cost per gigabyte.	Stores data and can be used in some laptops to transfer data.	
Flash drives	Flash disks are small, portable devices that connect to a computer using a USB port.	Flash drives are used when transferring files from computer to computer.	

#### LIFE SPAN OF A HARD DRIVE

Hard drives contain sensitive moving parts and because of this, they can fail. Data stored on hard drives should always be backed up (stored on another device). Modern hard drives can last for more than ten years.

The following signs show that the hard drive might be failing:

- The computer is slowing down
- There is a clicking or grinding sound
- The computer freezes frequently



#### Something to know

In January 2018, *SanDisk* (a flash disk manufacturer) unveiled the world's smallest one Tb flash disk at the consumer electronics show in Las Vegas. Although this is still only a **prototype**, it may eventually completely eliminate the need for external hard drives.

## CAPACITY AND ROBUSTNESS OF STORAGE DEVICES

The following table summarises the average capacity and robustness for different types of storage devices, provided that they are used correctly.

**Table 5.7:** *The average capacity and robustness of storage devices*

STORAGE DEVICE	STORAGE CAPACITY	ROBUSTNESS
Internal HDD	Up to 2 Tb	Hard drives contain sensitive moving parts and can be damaged if bumped or dropped, but they can last for many years if they are treated with care.
Portable HDD	Up to 2 Tb	Quite robust, but can easily get damaged if dropped. Some have a protective casing.
SSD	Up to 4 Tb	An SSD has no moving parts and cannot easily be damaged.
Flash drive	Up to 2 Tb	Flash drives are robust as long as they are treated carefully. They do not have moving parts.
SD card	Up to 512 Gb (but 1 Tb is possible)	SD cards are robust and cannot easily be damaged.

## CONNECTING PERIPHERALS

A peripheral is an external device that is connected to a computer. A PC on its own cannot function efficiently. It needs peripherals, such as a mouse or keyboard for the PC to operate properly.

Peripherals can be both cabled (wired) or wireless, and uses USB, Bluetooth or Wi-Fi. In this section, we will look at the different methods of connecting peripherals.



### Guided Activity 5.1

#### CABLED CONNECTIONS (USB)

To connect a keyboard with a USB cable, you can do the following:

1. Plug the USB cable of the peripheral device into the computer's USB port.
2. The computer will register the keyboard. You can then start using the keyboard immediately.

#### WIRELESS CONNECTIONS (BLUETOOTH)

To connect a new peripheral using Bluetooth, you can do the following:

1. Open *Settings*.
2. The *Settings* window will open.
3. Click on *Devices*.
4. From the left panel, click on the *Bluetooth & other devices* tab.

... continued



#### Take note

Install any drivers if prompted.



## Guided Activity 5.1

... continued

5. Turn the *Bluetooth* toggle switch on.
6. Click on the *Add Bluetooth or other device* button.

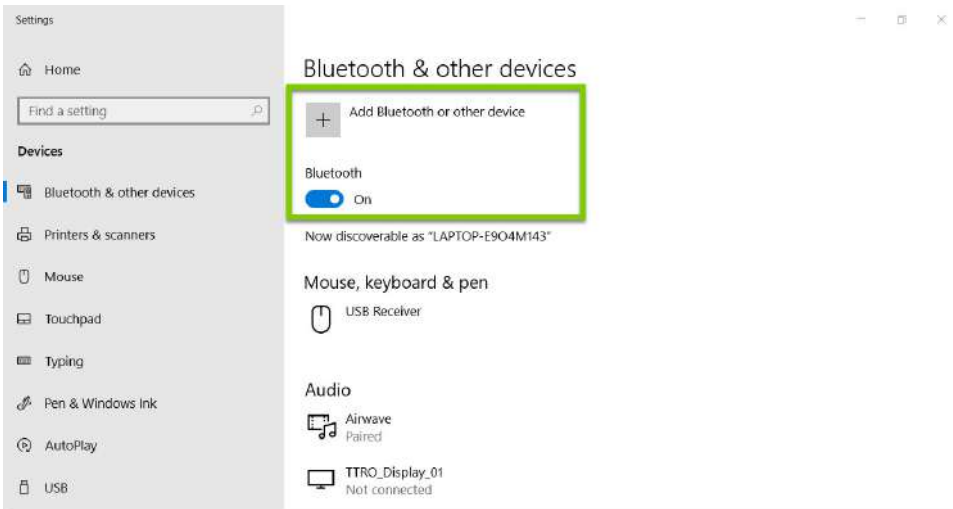

**Figure 5.6:** Adding a new peripheral using Bluetooth

7. Select the *Bluetooth* option.
8. Switch on the peripheral device.
9. A list of peripheral devices will appear. Choose the device and click it to connect.
10. Click on the connect button to pair.
11. Click *Done*.

### WI-FI

To connect a new peripheral using Wi-Fi, you can do the following:

1. Click on *Start > Devices and Printers > Add a printer*.
2. The *Add a printer* window will open.
3. Choose the *Add a network, wireless or Bluetooth printer* and follow the instructions.



## Activity 5.4

1. What is the smallest unit of storage capacity?
2. Which one of the following options describes the type of devices used to keep an electronic record of work done on a computer?
  - A. Input
  - B. Output
  - C. Processing
  - D. Storage
3. Fill in the missing word: There are 1 024 kilobytes in a \_\_\_\_\_.
4. Generally speaking, a hard drive has an average life span of three to five years, depending on the brand, size and type of environment.
  - a. Do you agree with the statement? Motivate your answer.
  - b. List two ways that indicate a hard disk is starting to fail.
  - c. Briefly explain why an internal hard disk is more prone to damage compared to a portable hard disk.

## 5.5 Green computing

Green computing is about using computers in an environmentally responsible and eco-friendly manner. Green computing aims to reduce the use and impact of hazardous materials, maximise energy efficiency and promote recycling of computers that are no longer being used.

Green computing tries to reduce the environmental effect of computers, by making computers more efficient and making sure the computers are built from biodegradable materials.

Some examples of green computing include:

- Computers going to “sleep” after they have been inactive for a certain amount of time.
- Data stored on SSDs use considerably less electricity than data on disk drives.
- Improved CPU architecture allows less electricity to create more power.
- More efficient software requires less processing and storage space, which requires less electricity.
- Better resource allocation means unnecessary computers in data centres can be turned off, saving a lot of electricity.

These improvements have already made significant improvements to the energy use of computers.

### GOING GREEN WHEN PRINTING

With printing, you need to understand the negative effect that printing has on the environment. Currently, too much paper is being wasted for printing; most printed copies are generally ignored or thrown away after they have been used once. We should print documents when necessary, and rather file and send documents electronically (for example, through email). You can also save paper by printing on both sides of the paper (double-sided printing), as well as by recycling paper.

Disposing printer cartridges in the wrong way (throwing them out in the environment) can cause serious damage to the environment. Rather, find a disposal outlet that has special bins for this purpose, for example, this type of outlet can be found at a local supermarket, such as PicknPay.



**Figure 5.7:** Example printer cartridge recycling outlets



### Activity 5.5

1. Explain the aim of green computing.
2. Describe three ways in which green computing can be achieved. Use ONLY examples related to hardware and software.

#### REVISION ACTIVITY

1. Match the ports in Column A to the connectors in Column B.

COLUMN A	COLUMN B
1. 	A. 
2. 	B. 
3. 	C. 
4. 	D. 

(4)

2. Write down the missing numbers:
  - a. 1 Mb = \_\_\_\_\_ Kb (1)
  - b. 1 Tb = \_\_\_\_\_ Mb (1)
3. In some laptops, internal hard disk drives are being replaced by SSDs.
  - a. What do the letters SSD stand for? (1)
  - b. Mention one advantage of using an SSD. (1)
  - c. Mention one disadvantage of using an SSD. (1)

... continued

## REVISION ACTIVITY

... continued

4. Mr Chotia has a small work-from-home business. He has a computer that he uses to do basic accounting and keeps a record of appointments with clients. He also needs to print out quotations and receipts.
  - a. Mr Chotia has purchased a desktop computer. Other than a printer, list three hardware devices that are essential for Mr Chotia to be able to use the computer. (3)
  - b. Which of the devices mentioned in (a) above can be used as both an input and as an output device? (1)
  - c. Mr Chotia has been advised to purchase a laser printer. Comment on this advice. (2)
  - d. Mr Chotia loads a file with a customer receipt into a word processor. He then prints out the receipt. Which of the above (file or print-out) would be referred to as a hard copy? (1)
  - e. Mention two ways in which Mr Chotia could connect the printer to the computer. Which method would you recommend? (4)
  - f. Mr Chotia is an environmentally aware member of the community. Mention two ways in which he can save paper in his business. (2)

**TOTAL: [22]**

## AT THE END OF THE CHAPTER

Use the checklist to make sure that you worked through the following and that you understand it.

NO.	DID YOU ...	YES	NO
1.	Learn what hardware is.		
2.	List the different ports and connectors.		
3.	Learn what input is.		
4.	Learn about the different input devices.		
5.	Learn what output is.		
6.	Learn about the different output devices.		
7.	Learn what storage is.		
8.	Learn about the different storage devices and their capacities.		
9.	Understand the importance of green computing.		

# EXTENDED HARDWARE CONCEPTS



## CHAPTER OVERVIEW

Unit 6.1	More about input devices
Unit 6.2	More about output devices
Unit 6.3	Storage media and devices
Unit 6.4	Processing devices
Unit 6.5	Caring for your PC and storage devices



At the end of this chapter, you should be able to:

- Describe the different input devices.
- Describe the different output devices.
- Explain the different storage media and devices.
- Explain what a processing device is.
- Describe the different processing devices.

## INTRODUCTION

Hardware devices can also come in the form of pointing devices, scanning and reading devices, microphones and many more. In this chapter, you will learn more about the different types of hardware devices, their features and uses.

## 6.1 More about input devices



As you learned earlier, an input device is any hardware device that allows you to enter data into or interact with the computer. This section will focus on the following types of input devices:

- Pointing devices
- Digital cameras
- Scanning and reading devices
- Video input devices
- Audio input devices
- Biometric input devices

### POINTING DEVICES

Pointing devices are used to control the movement of the cursor on the screen. Two examples of a pointing device are the mouse for the desktop computer and the touch pad for the laptop.

**Table 6.1:** *Different types of pointing devices*

TYPE OF POINTING DEVICE	DESCRIPTION	IMAGE
Touch pad	These are small rectangular pads that are mostly found on notebooks and laptops. You can move the mouse pointer on the screen by moving your fingers on the pad. Although notebooks and laptops do not need additional devices to move the mouse pointer, it is not the most efficient way to do it.	
Trackball	This is a stationary pointing device; an “upside down mouse” as some people call it. It has the same functions as a mouse, although the user makes use of the ball to move the cursor.	
Touch screen	Touch screens enable you to use your fingers to press the keys directly on the screen. Most smartphones and tablets are designed with touch screens, and it seems that notebooks are also following this design.	

... continued

TYPE OF POINTING DEVICE	DESCRIPTION	IMAGE
Stylus	A stylus is a pen-like device that is used draw, write, or select an object on a flat surface, such as the computer screen, mobile device, or tablet.	
Joystick	A joystick or game controller is a type of input device mainly used for games. It is made up of one or more buttons for special functions, such as moving an on-screen character and other action buttons linked to specific actions inside a game.	

## DIGITAL CAMERA

A digital camera is designed to capture and store images on a **memory card**. Digital cameras are available in different price ranges and require no film.



**Figure 6.1:** An example of a digital camera

## SCANNING AND READING DEVICES

### SCANNING DEVICES

Scanning devices are commonly used in offices, schools and even homes to scan documents, such as photographs and pages of text, and then convert it into a digital format. It reads typewritten, computer-printed or handwritten characters from ordinary documents and translates them into a form that the computer can understand.

**Table 6.2:** Types of integrated scanning devices

SCANNING DEVICE	DESCRIPTION	IMAGE
Flatbed	After the document or picture has been scanned, an electronic file is created by the scanner in the computer's memory.	
Multi-functional	Some printers come with four-in-one functions, which means that it can scan, email, copy and print.	
Handheld	A barcode scanner is an example of a handheld scanner. It is generally found in supermarkets or warehouses and is used to read a product's barcode. It uses a laser beam that uses light patterns that are able to decode vertical barcode lines.	
Mouse	This is a small and portable scanner that can easily be carried around. It can be used for text scanning, but because of its limitation in terms of resolution, it is not recommended for scanning photographs.	
Smartphone	A smartphone has the ability to act as a barcode and QR scanner. It can also scan documents, provided that you download the application for it. Smartphones scan by using the built-in camera of the phone.	

## READING DEVICES

There are several fields where reading or scanning technology is applied. In this section, we will explain these in some more detail.

### RADIO FREQUENCY IDENTIFICATION (RFID) READERS

RFID is a form of wireless communication that uses radiowaves to automatically identify and track tags attached to objects. These tags, called RFID tags, have the advantage in that they do not have to be positioned precisely relative to the reader, but can work within a few metres away (more or less five metres) from the reader.

Although this technology has been available for many years, mostly to track cattle, it has become a common technology for tracking consumer products worldwide. These tiny tags can be added to any product and can be scanned by an RFID reader. For example, manufacturers use these tags to help track the location of each product they produce until each is sold.





**Figure 6.2:** Type of RFID scanner

RFID tags come in various shapes and sizes, and may be covered in a variety of materials, such as:

- Rice-sized tags inserted underneath the skin of animals to identify them
- Screw shaped tags to identify trees or wooden items
- Credit-card shaped for use in access applications
- Anti-theft hard plastic tags attached to merchandise in stores
- Heavy-duty millimetre-rectangular transponders used to track shipping containers, heavy machinery, trucks and railroad cars

**Table 6.3:** Types of readers

READER	DESCRIPTION	IMAGE
Magnetic strip	A magnetic strip is often found on bank cards. A magnetic strip reader is able to scan the information contained in the strip, such as a bank account number, card number, name, expiry date of the card and pin number.	
Barcode	This is an electronic device that is used to decode and capture information in a barcode. This type of reader is used in places, such as shops and warehouses. A barcode reader is one of the devices that is used in a POS system.	
Quick response (QR) code	A quick response (QR) code is a type of barcode that contains information about the item to which it is attached. The user can download a QR reader application on his or her phone. You can use a QR reader to pay a bill at a restaurant, for example.	



## UNDERSTANDING URLS

Have a look at this video to understand how to use Zapper.



[https://www.youtube.com/watch?time\\_continue=10&v=9SW1dnqctGA](https://www.youtube.com/watch?time_continue=10&v=9SW1dnqctGA)



## Something to know

Before OCR technology, the only option to **digitise** paper documents was to retype them. This was a very time-consuming process and had the disadvantages of inaccuracy and typing errors.

### Example 6.1

Nowadays, you can use your phone to pay the bill, or even split the bill with a friend. This is done by scanning the QR code on the bill with Zapper. First, you have to sign up to the application and when the bill comes, use the application to pay the bill.

## OPTICAL CHARACTER RECOGNITION (OCR) SCANNERS

OCR scanners, also called *optical character readers*, can recognise almost any kind of typed, handwritten, or printed text inside images, for example in scanned documents or photos, and convert it into machine-readable text data.



**Figure 6.3:** An OCR scanner

The most popular application of OCR scanners is converting printed paper documents into machine-readable text documents that can be edited with a word-processing program. However, it can also be used to sort magazines and letters, and therefore, speed up mail delivery, for example.

## VIDEO INPUT DEVICES

Video input devices allow you to capture media, such as pictures, videos and sound, which can be stored on a computer, or on a storage device and accessed whenever you need them. The following are examples of common types of video inputs.



**Table 6.4:** Types of video input devices

DEVICE	DESCRIPTION	IMAGE
Video camera	Video cameras are designed to capture and store videos on a memory card. A video camera functions as an input device, as it can be connected to a computer or television to view the videos directly through these devices. The videos can also be transferred to a computer for storage purposes and viewing later.	
Web cam	A web cam is short for 'web camera' and is used to capture still pictures, or video images of a scene in front of it. It can be either built into a computer, or connected using a USB cable. It is used when making video calls, recording interviews on a computer, or taking part in a video <b>Skype</b> meeting.	

## AUDIO INPUT DEVICES

Audio input devices allow you to communicate with a computer using your voice. Because of the world in which we live, you can now talk to your friend in Spain via Skype, or video calling with the proper audio input. Some examples are discussed in the table below.

**Table 6.5:** Types of audio input devices

DEVICE	DESCRIPTION	USES	IMAGE
Microphone	A microphone is an input device used to input sound into a computer that is then stored in a digital form to be played back later. It can be used, for example, to add sound to a multi-media presentation, or to mix music.	Recording voice for podcasts: A podcast is an audio broadcast that is often listened to on a computer.	
Voice recorder	A voice recorder refers to any device capable of recording a voice message.	VoIP: VoIP stands for “voice over <b>internet protocol</b> ”, which makes it possible for users to make calls over the internet. Computer gaming: Used to talk to your team mates during a game.	

## VOICE RECOGNITION

Voice recognition, or speech recognition, is a type of computer program that is able to interpret spoken instructions and respond to them. In most cases, a microphone is necessary to be able to use the software. This microphone can be a separate device (desktop computer), or built-in (laptop and smartphone).

Computers using the Windows operating system include a speech-recognition program included called *Windows Speech Recognition*. Most smartphones have a built-in speech recognition software.

## BIOMETRIC INPUT DEVICES

Biometric inputs measure a person’s unique physical characteristic, with the most commonly used biometric being fingerprints. Other biometrics are hand or palm geometry and retina, iris, or facial characteristics. Behavioural characters include signature, voice, keystroke pattern and a person’s manner of walking.

Biometrics can be integrated into any application that requires security, access control and the identification and verification of people.







### Something to know

These days, smartphones have built-in voice recognition, which is designed to decode your voice and carry out verbal commands. The idea behind voice recognition is for the user to save time by designing software that can decode the human voice, eliminating the need for a keyboard. So, next time you are driving, and you need to find your friend’s location and text him something, remember the following:

With Google, tap the microphone symbol and state your command, for example: “Search for no. 84, Charles Street”, or “text Ronny”. The phone will do everything else for you!

**Table 6.6: Different biometric devices**

DEVICE	DESCRIPTION AND USES	IMAGE
Fingerprint scanner	Fingerprint scanners are one of the most developed and commonly used biometric devices. It serves as a type of authentication device that verifies the user's fingerprint by comparing it with the saved fingerprint data. It can, therefore, not be stolen, forgotten, borrowed, or forged. Nowadays, it is also a feature of most smartphones.	
Retina scanner	Uses the unique patterns on a user's retina blood vessels to identify the user. It is commonly used in high-security areas, such as research labs, banks, as well as government organisations.	
Iris scanner	Uses the patterns found in the coloured ring of tissue that is found around the pupil to identify the user. It is highly accurate and is used all over the world. It is used as a security at some banks and on some smartphones. In some countries, such as the United Arab Emirates (UAE), it is used at border posts to identify travellers.	
Facial recognition scanner	Facial recognition identifies the user by matching the nodal points of the user's face to the print that is on the system. Nodal points are different characteristics on a person's face that measure the length and width of the nose, cheekbones and eye socket width, for example. It is used in security systems. Social sites, such as Facebook, use facial recognition to tag users in pictures.	



### Something to know

Biometric inventions, such as fingerprint sensors and iris scanners, are commonly used in big companies and airlines to identify a person. However, experts predict that soon these biometric inputs will fall away, and facial recognition will rule the biometric security market.



## Activity 6.1

1. Touch screens enable users to use their fingers to press keys directly on the screen.
  - a. Give two examples of devices that use touch-screen technology.
  - b. What device can be used on a touch screen to draw or write on it? Also, give a brief description of this device.
2. Briefly explain the function of scanning devices.
3. Barcode readers are used in a variety of environments.
  - a. List any two instances where a barcode reader can be used.
  - b. Explain briefly how a barcode reader works.
4. Video inputs measure a person's unique physical characteristic, with the most commonly used biometric being fingerprints.
  - a. Which type of reader uses the patterns found in the coloured ring of tissue that is found around the pupil to identify the user?
  - b. List two places where this device is used.
  - c. What other scanner uses the eye as a form of identification?
  - d. Biometric devices are excellent in verifying a person's identity. List two advantages and two disadvantages.

## 6.2 More about output devices



Output devices are used to send information from a computer to another device, or to you as the user. In this section, you will learn about the following output devices:

- Headsets and speakers
- Multi-function devices
- Data projectors

### AUDIO OUTPUT

Audio output devices convert data on a computer into sound. This allows you to listen to music, chat to friends, or watch a movie or episode of a series on a computer.

**Table 6.7:** Types of audio output devices

DEVICE	DESCRIPTION	IMAGE
Headsets	Headsets are also referred to as earphones and are a hardware output device that is plugged into a computer, smartphone, or MP3 player so that you can listen to audio privately, without anyone else hearing what you are listening to.	
Speakers	Speakers convert data on a computer into sound. You can listen to music, or watch a show using your speakers. Determining the quality of speakers is a difficult task; however, having more speakers can increase the <b>surround sound</b> , but not necessarily the quality. Therefore, it is always advised to have two quality speakers to produce quality sound rather than many low-quality speakers.	



#### Something to know

Smart speakers are a new technology that is fast growing. It is currently available as single-unit wireless speakers with **artificial intelligence (AI)** from Amazon, Apple, Google, Microsoft, or Samsung built into them. This means that you can ask your smart speaker, for example, to play a song or playlist, to control the lights in a room, or ask for a weather report, and it will give you that.

### OTHER OUTPUT

There are a variety of other output devices used with computers and this section will look at some of these devices.

#### MULTI-FUNCTIONAL DEVICES

Multi-functional devices are able to perform various functions of several devices, but only takes the space of one, such as a four-in-one printer, where you can print, copy, fax and scan using just the one hardware device.

## DATA OR DLP PROJECTOR

Projectors use a bright light to project the images that would be displayed on a monitor on any flat surface, such as a wall or a screen. This then replaces the image on the monitor and an enlarged magnified image is shown on the screen, which can be viewed by a group of people. Projectors are used in schools and offices, with bigger projectors used in cinemas.

There are two types of data projectors:

1. Liquid crystal display (LCD) projectors
2. Digital light processing (DLP) projectors

Most projectors use DLP technology.



**Figure 6.4:** Example of a projector

### Activity 6.2

Match the terms in Column A with the descriptions in Column B.



COLUMN A	COLUMN B
1. Headsets are also referred to as _____	A. Projector
2. Converts data into sound	B. Watts
3. Multi-functional device	C. Speaker
4. Replaces the image on the monitor and magnifies the image on the screen	D. Earphones
5. Loudness of a speaker	E. Printer

## 6.3 Storage media and devices

In the previous chapter on hardware, you learned that storage devices all serve the same general purpose – i.e. to store data. In this section, you will learn more about:

- CDs, DVDs and Blu-Ray
- Memory cards
- Card readers

**Table 6.8:** *Types of storage devices*

DEVICE	DESCRIPTION	USES	IMAGE
CDs, DVD and Blu-Ray	Compact discs (CDs), Digital Versatile Discs (DVDs) and Blu-Ray discs are still three of the most commonly used forms of portable storage.  The sizes of the different media are: CD: Up to 0.9 Gb DVD: Up to 9.7 Gb Blu-Ray: Up to 50 Gb	This is mainly because music, series and movies are stored and sold on these discs. However, data files from a computer can also be copied on the discs, using the correct CD, DVD or Blu-Ray writer. Even though DVD drives can read CDs, CD drives cannot read DVDs and a special Blu-Ray drive is needed to view and use Blu-Rays.	
Memory card	A memory card is a storage device. You will find it in many portable electronic devices, such as phones, digital cameras and media players.	It is mainly used for storing digital information. Although it can be used to transfer files between different devices, it is usually too small and too expensive to use for this purpose.	
Memory card reader	This device reads memory cards. It is usually built-in in some printers and smartphones, as well as most personal and tablet computers.	Used to read memory and SD cards.	



### Something to know

CD/DVD drives in laptops are starting to become obsolete. Nowadays, manufacturers have started to leave optical drives out, which enables the laptops to be lighter and less expensive.



### Activity 6.3

There are many storage devices that are available currently.

1. Which type of storage device is best used in a smartphone?
2. Briefly describe the storage device you mentioned in (a).

## 6.4 Processing devices

When a computer receives data from an input device, for example the mouse or keyboard, the data must be processed before it can go to an output device, such as the printer or monitor. A processing device is responsible for converting that data into useful information.

In this section, we will look at the following processing devices:

- Motherboard
- **Central Processing Unit (CPU)**
- **Random Access Memory (RAM)** and **Read-only memory (ROM)**

### MOTHERBOARD

The motherboard can be compared to the skeleton of the human body; it connects all the parts of a computer together. You can also think of it as a mother that holds all her children (pieces) together.

The motherboard is a large printed circuit board connecting all the different components in a computer, such as the CPU and RAM.



**Figure 6.5:** An example of a motherboard

There are also connectors on a motherboard allowing you to connect a power supply to the computer and finally, it has a number of ports in the back that allow you to easily plug in devices, such as keyboards, speakers and monitors.

### CENTRAL PROCESSING UNIT (CPU)

Think of a computer as a human body with the CPU being the brain, controlling everything the computer does.

The CPU is the part of a computer responsible for receiving and carrying out computer instructions. It does this by making use of millions (or even billions) of transistors, which can each be switched on or off individually.



#### Something to know

Phones, tablets and other small computerised devices also have motherboards, often called *logic boards*.



#### EXPLORING A MOTHERBOARD



<https://www.youtube.com/watch?v=Zjrayb7E9tl>



### Something to know

Many people call their computers the CPU – this is incorrect as the CPU is only a chip found inside a computer.

Each CPU can be made up of multiple **cores**, which are independent processing units that can complete tasks on their own. By adding multiple cores to a CPU (which is then called a *multi-core processor*), a computer can dramatically increase the processing power available to it.

The speed of a CPU is measured in **gigahertz (GHz)**, which shows how many instructions can be performed in one second. One GHz is equal to a 100 million hertz.

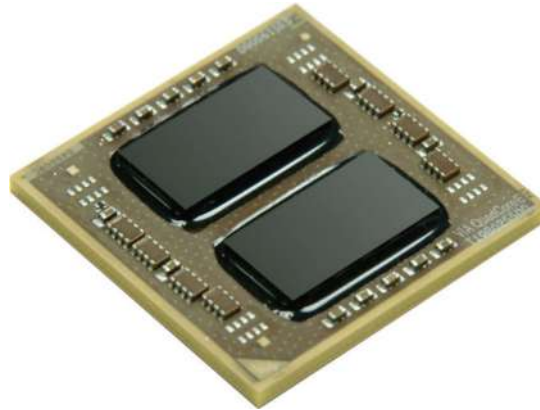

**Figure 6.6:** An example of a CPU quad core

The CPU was first developed during the 1970s at Intel, with the first processor, the 4004 processor, released.

The type of processor determines the speed and its capabilities. In the past, computer processors used numbers to identify and name the processor. For example, the Intel 80486 (386) processor is faster than the 80386 (286) processor. However, after the Intel Pentium processor was developed, processors started getting names, such as Pentium, Celeron and Duron.

## MEMORY

You learned about hard drives earlier on. Other than the hard drive, there is the random access memory (RAM) and read-only memory (ROM).

**Table 6.9:** RAM and ROM

DEVICE	DESCRIPTION	FEATURES	IMAGE
RAM	RAM is used to store the programs and data used by the CPU in real time. Data on RAM can be read, rewritten, or erased when needed to.	The data that is stored on the RAM is erased the minute you switch off the computer. It requires a constant supply of power to keep the data safe. This is called <b>volatile memory</b> and is why we cannot use RAM as a permanent storage device, even though it is way faster than normal hard drives.	

... continued

DEVICE	DESCRIPTION	FEATURES	IMAGE
ROM	The ROM is used when a computer starts up; it uses the information that is stored on the ROM to start up.	ROM is a non-volatile memory; it will not forget any data that is stored on it, even after the computer is switched off, or if the power supply is turned off.	



### Something to know

The first writeable RAM was magnetic core memory invented in 1951.



### Activity 6.4

This will be a group activity. The teacher will arrange you in groups. Each group will be asked to research a specific processing device, such as:

- Motherboard
- CPU
- RAM and ROM

Each group should give a description of the device. Their role (use) in a computer and importance thereof. In order to do so, you need to do the following:

1. Each group must create a PowerPoint presentation with a maximum of eight slides (containing a cover, content and reference slide) on research of the assigned topic.
2. Each group will present the research done on the topic.
3. Your teacher will give you an assessment task to complete, based on the information found by all the groups.

## 6.5 Caring for your PC and storage devices



### Something to know

Always remove a flash disk or external hard drive safely from the computer. This can be done by right clicking the *Removable storage* icon in the *Computer* window and select *Eject*. Yes, it might seem tedious, but in the long run, it will help you by preventing any data corruption.

You must always take care of your PC system and storage devices, as some of the components and the information loss can be quite costly. To take care of your PC, keep food and drinks away from it and keep back-ups on a storage device, such as an external hard drive. Also install an **antivirus program** and keep your PC clean. These are just some examples of taking care of your PC.

For storage devices, examples would be that CDs and DVDs can get scratched, making them unreadable. Flash disks are small and can easily land on the floor. When stepped on, they can become damaged. They can also be damaged by water and high temperatures, or other environmental factors. Even normal wear can cause them to become unusable.

Although external hard drives are normally resistant to damage, care should be taken not to drop them as they contain small parts that can easily be damaged.

Always take care of your computer, shut it down in the correct way when you are done using it, so that the computer can last for a long period of time.



### Guided Activity 6.1

Do the following activity with the rest of your class mates. Your teacher will help guide you in this activity.

To check the size of a hard disk and the space available on a plugged-in storage device, the following should be done:

1. Double click on the *My Computer* icon in the *Start* menu.
2. From the *My Computer* window, right click on the icon that shows the drive that you want to look at.
3. In this case, we will look at the *Windows (C:)* icon.
4. Right click on the icon.
5. Click on *Properties* from the drop-down menu, this will display the properties of *Windows (C:)* in the dialogue box.
6. The dialogue box will show the disk space, available free space and the capacity of the disk, as seen in Figure 6.7.

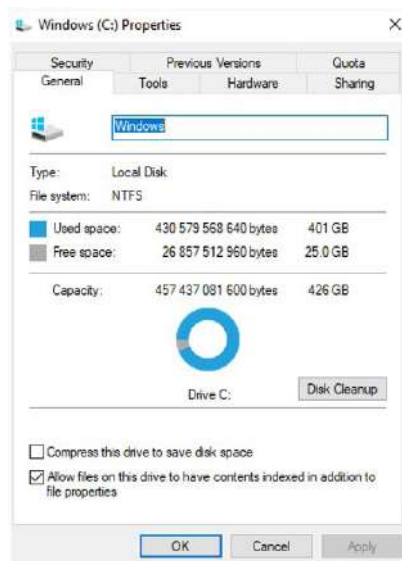

**Figure 6.7:** Properties window of Windows (C:).

## REVISION ACTIVITY

For questions 1 and 2, write down the number of the question and the letter that matches the correct answer, e.g. 9 C.

1. Which of the following devices is MOST likely to have a touch pad?
  - A. Desktop computer
  - B. Foldable keyboard
  - C. Laptop computer
  - D. Touch-screen monitor(1)
2. Which of the following is NOT a pointing device?
  - A. Trackball
  - B. Stylus
  - C. Digital camera
  - D. Joystick(1)
3. Petrus works in the office of a large company. One of his responsibilities is to scan many documents and store them in digital format on the company server. Some of the documents can be up to 20 pages long. Should the company use a stand-alone flatbed scanner, or a scanner included with a multi-functional printer? Give a reason for your choice.(3)
4. Many people have a small RFID chip implanted in their pets. The chip stores a unique identity number. If the pet goes astray and is found by someone else, it can be taken to a veterinary practice where the vet can use an RFID scanner to check who owns the pet.
  - a. What do the letters RFID stand for? (1)
  - b. Mention one other use for RFID chips. (1)
5. Study the image below showing the components inside a desktop computer's tower.



- a. What is the function of the motherboard? (2)
  - b. Without referring to the human brain, explain what the function of the CPU is. (2)
  - c. Computers have two types of memory, RAM and ROM. Compare RAM with ROM by listing two differences between them. Write your answer in a table format. (5)
6. List two devices that use memory cards as additional storage. (2)

... continued

## REVISION ACTIVITY

... continued

7. CDs, DVDs and Blu-Ray discs can all be used as storage media.
- Which of these storage media has the lowest capacity? (1)
  - Which of these storage media would be most suitable to distribute a 3D movie? (1)
8. In a number of places in this textbook, you will find images like the one below that take you to a website or resource when scanned.



- This image looks like a barcode in two dimensions. What is it called? (1)
  - What software do you need to scan the image? (1)
  - Use a smartphone to scan the image. Write down the URL of the website that it opens. If you do not have a smartphone, ask a friend or your teacher to help you. (1)
9. Chris Hani Secondary School has installed a fingerprint scanner. Staff have to use the scanner when they arrive at school and again when they leave. The scanner software is used to keep records on staff attendance.
- The fingerprint scanner is a biometric input device. Explain briefly what is meant by biometric input. (2)
  - Name one other type of biometric scanner. (1)
10. Faizal has bought a portable speaker from an online shopping site.



The following specifications were found on the website:

- Speaker Size: 3 inch
- Speaker output: 9W, 40hm
- Battery Capacity: 1000mAh
- Frequency response: 100-20kHz
- Bluetooth version: V2.1
- Supports up to 32 GB on a USB and SD card
- AUX-in port. Rechargeable lithium battery

- Faizal wants to use the speaker to play music that is stored on his smartphone. How would he connect his smartphone to the speaker? (1)
- Faizal wants to play music without connecting to his smartphone. Which two storage media could he use? (2)

**TOTAL: [29]**

## AT THE END OF THE CHAPTER

Use the checklist to make sure that you worked through the following and that you understand it.

NO.	DID YOU ...	YES	NO
1.	Learn about pointing devices.		
2.	Learn about scanning and reading devices.		
3.	Understand what video and audio output devices are used for.		
4.	Understand the different types of biometric devices.		
5.	Learn about audio and video output devices.		
6.	Learn about the different types of projectors.		
7.	Understand the functions of the different processing devices.		
8.	Learn about storage media, such as CDs, memory cards and DVDs.		
9.	Understand the importance of taking care of your PC.		



## CHAPTER OVERVIEW

Unit 7.1 Basic software concepts

Unit 7.2 Operating system

Unit 7.3 Being more secure



At the end of this chapter, you should be able to:

- Describe what software is.
- Describe the types of software.
- Describe the differences, advantages and disadvantages of each type of software.
- Describe what an operating system is and give examples thereof.
- Describe what GUI is and give examples of some of the elements.
- Explain basic PC security.



## Something to know

The term “software” was not used until the late 1950s. In 1948, computer scientist, Tom Kilburn, was responsible for writing the world’s first piece of software. Kilburn and one of his colleagues created one of the earliest computers, which was called the Manchester Small-Scale Experimental Machine (SSEM), also known as the “Baby”. The SSEM used coded instructions programmed into it to do mathematical calculations. This piece of software took 52 minutes to correctly calculate  $2^{18}$ , which is 262.144.

## INTRODUCTION

In Chapter 1, you learned that software is a set of programs or instructions that tells the computer and its hardware how to perform specific tasks. Without software, most computers would be useless, for example without Microsoft Word software it will be difficult to type out assignments and use specialised fonts and WordArt.

In this chapter, we will look at the basic software concepts, different software components and different types of software.

## 7.1 Basic software concepts

In this unit, we will look at the different concepts used in software. To begin, however, we will look at the different types of software.

Software consists of the following two categories, which will be explained in detail later on:

- 1. Application software:** Application software allows you to perform tasks, such as playing games, creating slide show presentations, creating spreadsheets, and so on. There are many different types of application software programs.
- 2. System software:** This includes the operating system and other software that controls and manages the operation of the computer.

### APPLICATION SOFTWARE

Whether it is creating a report for work, typing out an assignment for school, messaging a friend, or just trying to find out where you can buy the latest PlayStation, there is probably an **application (app)** that can help you find what you are looking for. Unfortunately, there is no application that explains what it is, or what it does. So, in this section we will look at this term and how it has developed – and you do not even need an application to read it!

As you have learned, computer software is a set of instructions that tells a computer what to do and how to do it. Although the computer cannot run without system software, application software is the most useful type for computer users, as it helps us perform many of the tasks that make us use computers in the first place, such as web browsing, word processing and spreadsheet processing.

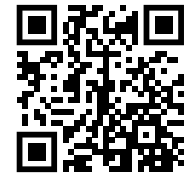

**Figure 7.1:** *Different software applications*

Over recent years, classifying applications according to computing platforms has become more difficult. A platform is the combination of hardware and software required to make an application run. In the past, the type of software running on a computer depended on the



WHAT IS SOFTWARE?



<https://www.youtube.com/watch?v=grrYbJqnSzY>

operating system, for example, some software works with a Windows operating system; other software only works with an iOS or Unix system. That has changed, however; new development in software has resulted in many applications no longer relying on a specific operating system, it runs on the **web** and can be accessed through a browser.

## TYPES OF APPLICATION SOFTWARE

The table below shows some of the different types of application software installed on a computer. You should note that although software is identified as a program, it can be anything that runs on a computer.

**Table 7.1:** Examples and types of application software

APPLICATION SOFTWARE	EXAMPLES
Office suites	Microsoft Office, Libre Office, Google G-Suite
Internet browser	Chrome, Firefox, Internet Explorer, Edge
Movie player	VLC, Windows Media Player
Presentations	PowerPoint
Word processor	Microsoft Word
Portable Document Format (PDF)	Adobe Acrobat Reader, Foxit Reader
Operating system	Microsoft Windows, Linux, Android, iOS
Antivirus	Norton, AVG, McAfee, Symantec, Windows Defender
Spreadsheets	Microsoft Excel
Accounting	Pastel, QuickBooks
Gaming	Minesweeper, Solitaire, Counter Strike
Designing and graphics	Adobe Photoshop, AutoCAD

Some application software, such as *Wordpad*, *Notepad*, *Calculator*, *Paint* and the *Snipping Tool*, all come packaged with the system software of the Microsoft Windows operating system. We will briefly look at these basic programs and how they can be useful to you.

## ACCESSORIES

Microsoft Windows includes a few programs, such as the *Calculator*, *Paint* and *Snipping Tool*. You can start any **accessory** from the *Start* menu. An accessory is any device or program that is not necessarily required, but it can be added to a computer to perform an additional function.

## WINDOWS CALCULATOR

To use the Windows Calculator accessory you can do the following activities:



### Guided Activity 7.1

1. Click the *Start* button.
2. Type in *calc*.
3. Click *Calculator* from the search results.

... continued

### Something to know

In a few years' time, application software will develop even more. According to software developers, we are likely to see less emphasis on desktop PC software and an increased emphasis on **cloud** and mobile applications. Although this may benefit users in terms of user-friendliness, it can lead to potential privacy and security risks.

### Something to know

You can access these programs by clicking on the *Start* menu and searching for the program.



### Guided Activity 7.1

... continued

The calculator will appear on your desktop.

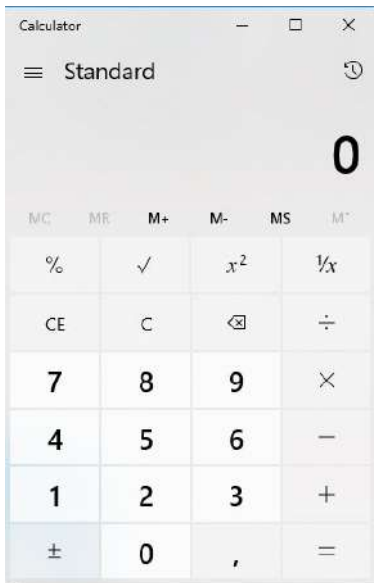

Figure 7.2: The Calculator application



### Guided Activity 7.2

To perform a simple calculation, you can do the following:

1. Use the keyboard to type in the required data.
2. Or, you can type in the data by using the mouse and clicking on the buttons of the calculator.
3. Press the *Enter* key to get your answer.

## SNIPPING TOOL

This tool captures all, or part of the computer screen as an image. You can save this image, attach it to an email, or even paste it into another application, such as Microsoft Word or Microsoft Paint.



### Guided Activity 7.3

To access this program, you can do the following:

1. Click on the *Start* menu.
2. Type in *snip*.
3. Click on the *Snipping Tool* from the search results.

To capture a snip, you can do the following:

4. In the *Snipping Tool*, select *Mode*. You can choose any of the following types of snips:
  - Free-form snip
  - Rectangular snip
  - Window snip
  - Rectangular snip

... continued



### Something to know

Did you know that you can change the type of calculator from standard to scientific, or to a programming calculator by clicking on the icon (☰) on the left-hand side of the calculator. So, next time you have some homework that requires a calculator, maybe this program could be of some use.



## USING THE SNIPPING TOOL

You can learn how to snip the computer screen by opening the QR code shown below.



[https://www.youtube.com/watch?v=J6S09zf\\_QL0](https://www.youtube.com/watch?v=J6S09zf_QL0)



### Guided Activity 7.3

... continued

5. Select the area that you want to snip.

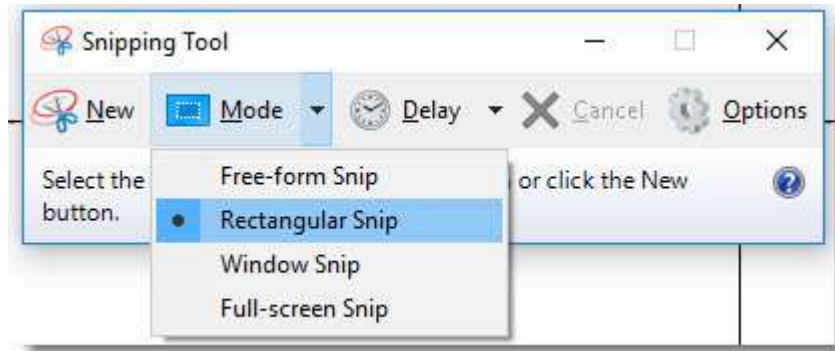

Figure 7.3: The Snipping Tool

6. After you have captured your snip, save the snip.
7. This is done by clicking on *File > Save As*.
8. Type a file name and then click on *Save*.

## PAINT

Microsoft Paint is an accessory that provides virtual pens and brushes to create art or even text.



### Guided Activity 7.4

To use this program, you can do the following:

1. Click on the *Start* button.
2. Type in *paint*.
3. Click *Paint* in the search results.

The *Paint* window will then open and you can create your own canvas by clicking or dragging the mouse, or by using the brushes.

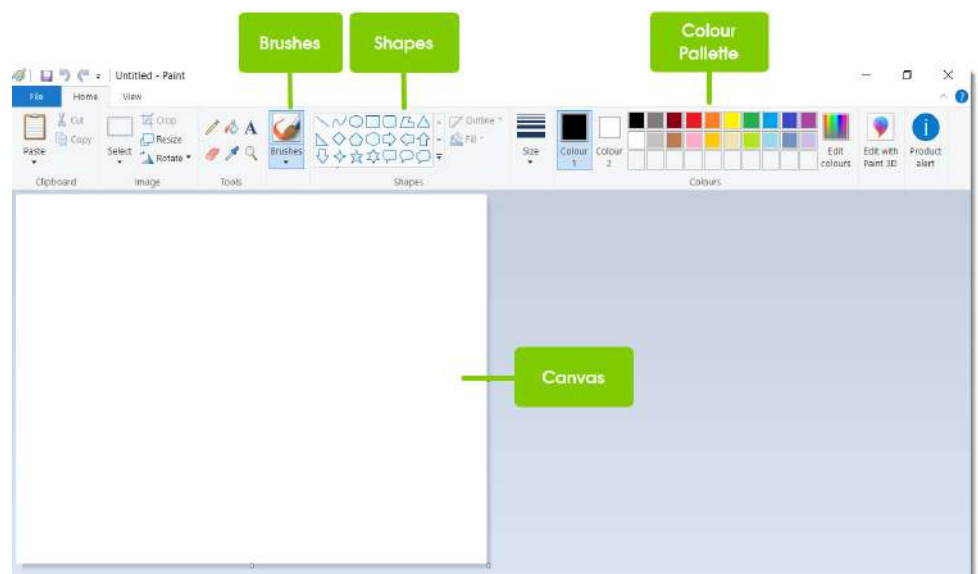

Figure 7.4: The Paint tool

## SYSTEM SOFTWARE

System software is the specific type of software that manages the computer. Much like a traffic officer at a busy intersection, the system software manages the flow of data and information in the computer. This is done in the following ways:

- Translating the instructions from the software to a language that the hardware can understand
- Sending these instructions to the correct hardware
- Receiving information from the hardware (such as, the button press on a keyboard) and sending it to the software
- Allowing different applications to speak to each other
- Making sure all the hardware and software on the computer are in a good condition

The operating system (OS) is the most important type of system software as it manages all the other programs in the computer.

### TYPES OF SYSTEM SOFTWARE

The table below shows some of the different types of system software installed on a computer.

**Table 7.2:** Examples and types of system software

SYSTEM SOFTWARE	EXAMPLES
Operating systems	Microsoft Windows, Linux, Android, iOS
Device drivers	Drivers for the mouse, keyboard, sound card, display card, network card, printer, etc.
Firmware	Firmware is the operational software embedded within a flash drive, ROM, or EPROM memory chip for the operating system to identify it
Utilities: This kind of software is designed to maintain the computer	Antivirus and security software Disk partition services Disk defragmentation File compression Data back-up for security reasons Hardware diagnostic services Data recovery Firewall Screensaver



#### Activity 7.1

1. What is a platform?
2. Match the following software in Column A with the correct example in Column B:

COLUMN A	COLUMN B
1. Internet browser	A. AVG
2. Presentations	B. Chrome
3. Antivirus	C. VLC
4. Movie player	D. PowerPoint



## Take note

Before everything else, the operating system is the first thing loaded onto the computer. Without the operating system, a computer is pretty useless.



## UNDERSTANDING THE OPERATING SYSTEM



<https://www.youtube.com/watch?v=pTdSs8kQqSA&list=PL4316FC411AD077AA&index=8&t=0s>

When you turn on a computer, it is nice to be able to move the mouse, play music, or even browse the web with just a click. However, as easy as it looks, there is a lot going on inside the computer and the real mastermind behind handling all the necessary tasks, is the operating system. Most desktops or PCs come preloaded with Microsoft Windows while **Macs** are preloaded with Mac OS X. Other PCs and desktops may use the Linux or UNIX operating systems.

Recently, operating systems are found in smaller computers and devices that we use every day; from smartphones to **wireless access points**. The purpose of an operating system is to organise and control both the hardware and software to perform specific tasks.

Any device that has an operating system allows you to change how the device works. This means that you can add a new security update, a new application, or even install a new operating system (depending on compatibility) whenever you want to. So, no need to throw your computer away each time you need to add a new application or update! As long as you understand how an operating system works, you can change some of the ways in which it operates; the same applies for your phone.

What exactly can an operating system do? In the following section, we will take a brief look at the role that the operating system plays.

## THE ROLE OF THE OPERATING SYSTEM

The operating system of a computer manages all the software and hardware of the computer. In other words, the operating system has many different functions and jobs. In most cases, people generally have a number of programs running at the same time on their computers. These programs all need to access the computer's CPU, storage and memory. The operating system manages and coordinates these processes so that the program gets what it needs to run.

## THE OPERATING SYSTEM AND GUI

Operating systems are usually preloaded onto any computer you buy. Most users use the operating system that comes with their computers; however, this can be updated or even changed when required. The most popular operating systems for PCs are Microsoft Windows, Mac OS X and Linux.

Modern operating systems use a graphical user interface (GUI). This interface allows you to use the mouse to click on buttons and the keyboard to type text; while everything is shown clearly on the display screen as graphics and text.

Each operating system has a different look; so, if you decide to change operating systems at some point, it might initially feel weird and unfamiliar. However, modern operating systems are designed to be easy to use and the basic operating principles are the same.

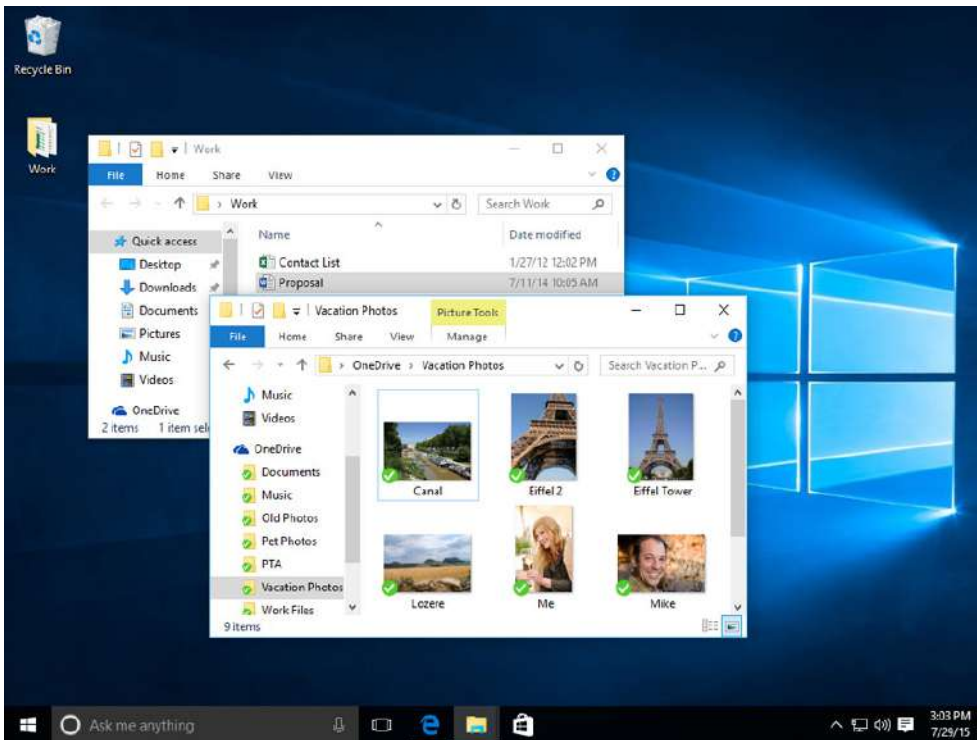

**Figure 7.5:** GUI of a Microsoft Windows operating system

### TYPICAL FEATURES OF A GUI

A GUI uses windows, icons and menus to perform commands, such as opening, moving, closing and deleting files. Although most GUI systems use the mouse to navigate, it can also use hotkeys and arrow keys.

**GUI elements** are included, but not limited to the following:

- **Input controls:** Checkboxes, option buttons, list boxes and dialogue boxes
- **Navigational components:** Icons, menu usage and navigation
- **Informational components:** Toolbars and message boxes

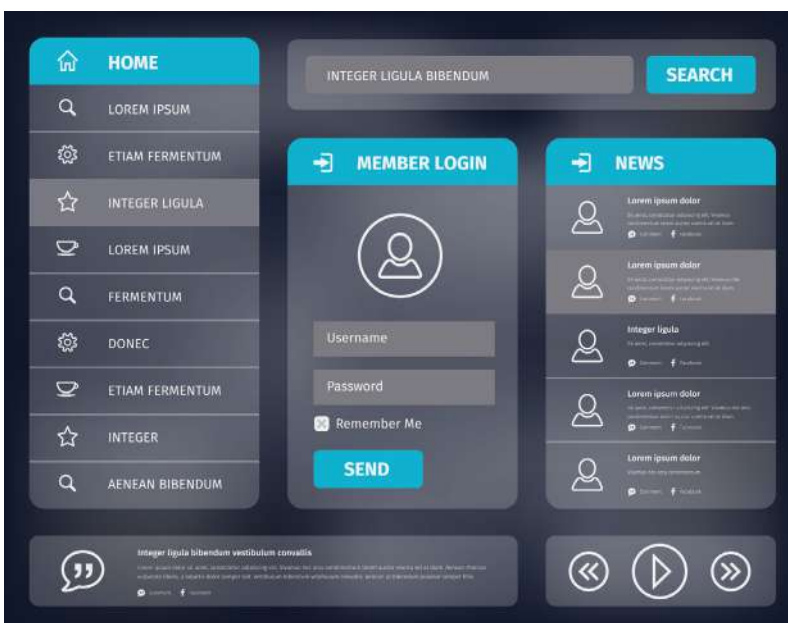

**Figure 7.6:** Examples of user interface elements

These operating system elements are grouped in tables and are briefly discussed below.

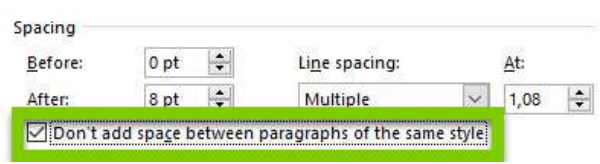
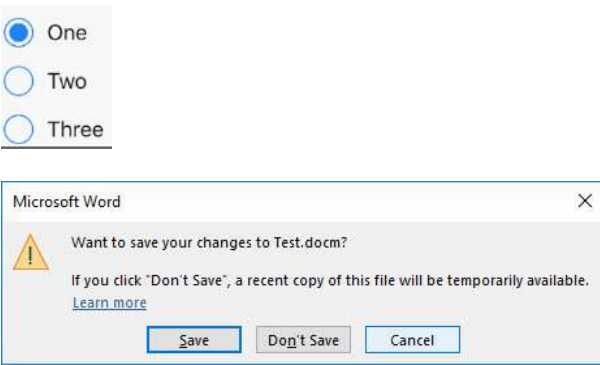
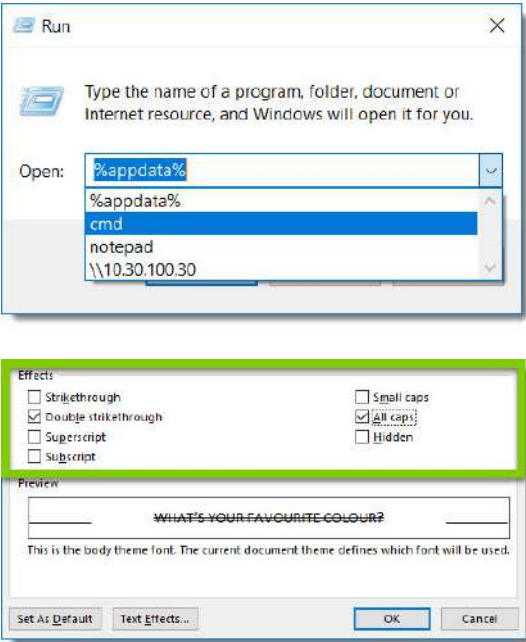
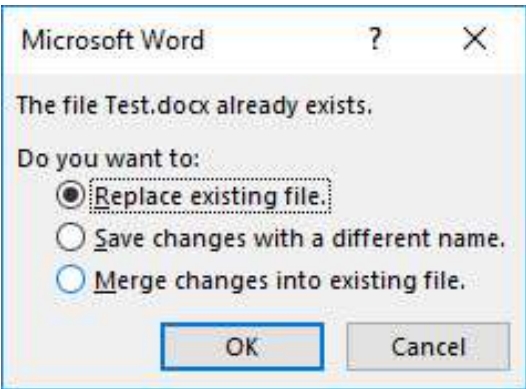

**Table 7.3: Input controls**

ELEMENT	DESCRIPTION	IMAGE
Checkboxes	Checkboxes allow you to select one or more options from the list.	
Option buttons	These buttons let you choose or select one item at a time.	
List and combo boxes	<p><b>List box:</b> This is a box that has a variety or list of options; however, only one option can be selected.</p> <p><b>Combo box:</b> This is a dialogue box that has a variety of controls, for example text boxes, sliders and drop-down lists.</p>	
Dialogue boxes	A dialogue box is a temporary window that an application creates to receive input from the user. It prompts the user for additional information.	

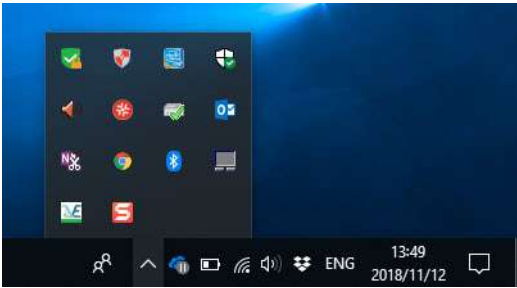
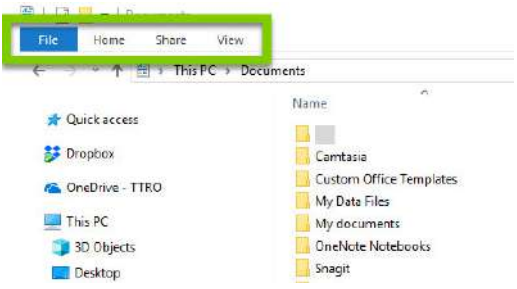
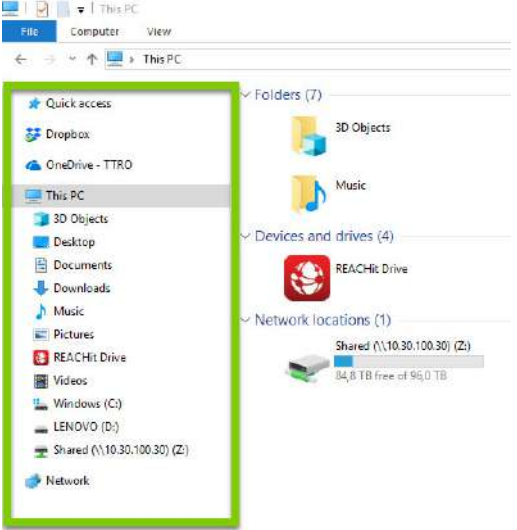
**Table 7.4: Navigational components**

ELEMENT	DESCRIPTION	IMAGE
Icons	An icon is a picture that has a symbol, which can help you navigate to a specific program. It can be found on the <b>taskbar</b> , or PC Home screen.	 A screenshot of a Windows desktop environment. The desktop background is blue. In the center, there is a grid of application icons including File Explorer, Microsoft Edge, and various utility programs. At the bottom, the Windows taskbar is visible, showing the Start button, several pinned application icons, and the system tray with the time and date (13:49, 2018/11/12).
Menu	A menu bar is a thin, horizontal bar that has drop-down menus. It allows you to find a program's functions, such as opening or closing files.	 A screenshot of a Windows File Explorer window. The window title is 'Documents'. The menu bar at the top includes 'File', 'Home', 'Share', and 'View'. The 'File' menu is highlighted with a green box. Below the menu bar, the left sidebar shows navigation options like 'Quick access', 'Dropbox', and 'This PC'. The main pane shows a list of folders in the 'Documents' directory, including 'Cambasia', 'Custom Office Templates', and 'My documents'.
Navigation bar or pane	This is a set of buttons or graphics in a row that allow you to click on an option that will give you more information.	 A screenshot of a Windows File Explorer window. The window title is 'This PC'. The menu bar includes 'File', 'Computer', and 'View'. The left sidebar, which is highlighted with a green box, contains a navigation pane with options like 'Quick access', 'Dropbox', 'OneDrive - TTRO', 'This PC', '3D Objects', 'Desktop', 'Documents', 'Downloads', 'Music', 'Pictures', 'REACHit Drive', 'Videos', 'Windows (C:)', 'LENOVO (D:)', 'Shared (\10.30.100.30) (Z:)', and 'Network'. The main pane shows a view of 'This PC' with sections for 'Folders (7)', 'Devices and drives (4)', and 'Network locations (1)'.

**Table 7.5: Informational components**

ELEMENT	DESCRIPTION	IMAGE
Toolbars	A toolbar gives you quick access to frequently used commands.	 A screenshot of the Windows taskbar. It shows the Start button on the left, followed by a search bar, and a row of pinned application icons. The system tray on the right contains icons for network, volume, and power, along with the time and date.
Message boxes	A message box is similar to a dialogue box; the computer gives you a message based on the data that you entered.	 A screenshot of a Windows error message box titled 'Restoring Network Connections'. The box contains a yellow warning triangle icon and the following text: 'An error occurred while reconnecting Z: to \\10.30.100.30\Shared Microsoft Windows Network: The local device name is already in use. This connection has not been restored.' There is an 'OK' button at the bottom right of the box.

## DIFFERENT OPERATING SYSTEMS

The three popular operating systems for PCs are:

1. Microsoft Windows
2. Mac OS X
3. Linux

### MICROSOFT WINDOWS

Microsoft Windows is one of the most popular operating system. Microsoft is calling Windows 10 “the last version of Windows”. This is not because it is killing off Windows, but because it decided to rather keep improving and updating Windows 10.



**Figure 7.7:** Windows user interface

### MAC OS X

This is a range of computer systems created by Apple. All Macintosh computers, better known as Macs, come preloaded with this operating system. All their recent versions are known as OS X with, the latest version that was released in 2018, called *Mojave*.



**Figure 7.8:** Mac “El Capitan” user interface



#### Something to know

According to *StatCounter Global Stats*, there are only about 10% Mac OS X users of global operating systems, which is really low compared to Windows users (about 80%). A reason for this is that Apple computers tend to be much more expensive; although most people prefer the look and feel of Mac OS X over Windows.

The iPhone and iPad both have the iOS 9 user interface.

## LINUX

Linux is a group of open-source operating systems. This means that it can be modified and distributed across the world by anyone. The advantages of Linux are that it is free and there are many different versions from which you can choose, for example, Linux Mint, Ubuntu, CentOS 7, etc.



Figure 7.9: Linux user interface

## MOBILE OPERATING SYSTEMS

All of the previously mentioned information on operating systems is pretty much designed to only run on desktops or laptops. Mobile devices, such as phones, tablets and iPads differ from PCs or laptops and, therefore, have different operating systems designed just for them. Examples of these systems are Google Android, Apple iOS, Nokia Symbian, BlackBerry OS, etc.

Most mobile operating systems are tied to specific hardware, with little flexibility. It also does not have as many features as the operating systems of PCs and laptops, and the different devices cannot all run on the same software.

Mobile devices with communication abilities, for example smartphones, have the following two operating systems: the main user-facing software **platform** and a second lower-level **proprietary** real-time operating system, which operates the radio and other hardware.

A mobile operating system starts when the device is powered on, presenting a screen with various icons or **tiles** that provide specific information and application access. It also manages cellular and wireless network connectivity, as well as phone access.



### Something to know

According to *StatCounter Global Stats*, Linux users are less than 2% of global operating systems. Most servers run on Linux, which makes it easier to customise.



## Activity 7.2

Are the following three statements true or false? If false, provide the correct answer.

1. The operating system is a type of hardware.
2. Modern operating systems use a graphical user interface (GUI).
3. A menu bar gives you quick access to frequently used commands.
4. Which one of the following systems is an open-source operating system?
  - a. Linux
  - b. Windows
  - c. Mac OS
5. Look at the diagram below and answer the questions that follow.

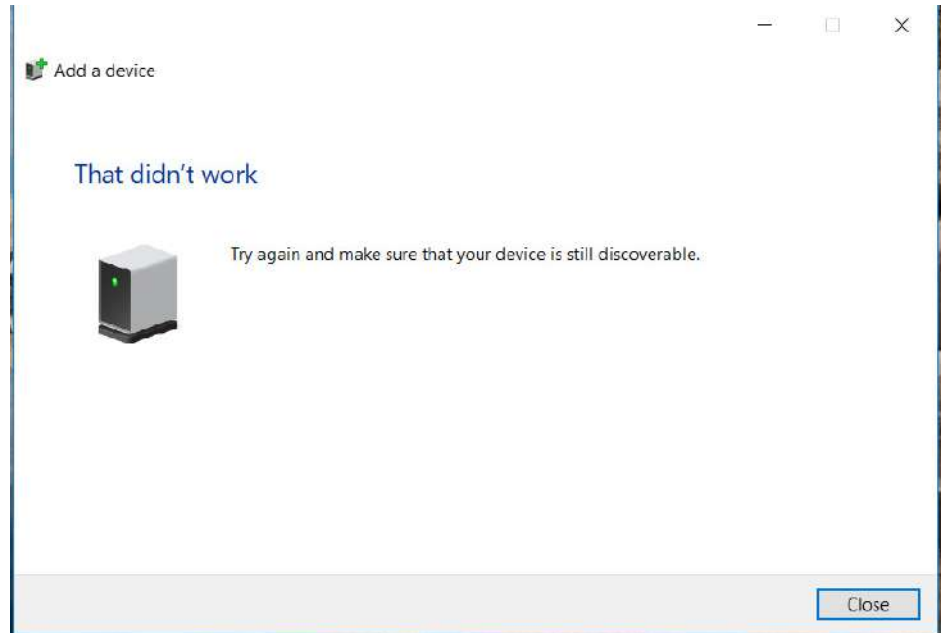

- a. What type of GUI element is shown in this diagram?
- b. Explain the type of element shown. Give a brief description of this element.
- c. The diagram shows that the user was trying to connect to a peripheral device. Is this statement true? Motivate your answer.
- d. According to the diagram, what method of connection is being used (this will be based on your answer in question c above)?

## 7.3 Being more secure

Computer security is something every computer user should take very seriously. A breach in security can cause major problems. This means that you must do certain things to prevent and detect unauthorised access to your computer. *Unauthorised use* refers to anyone that gets access to your computer without your permission. In the worst-case scenario, this can refer to hackers who break into computer systems to steal, change or destroy information.

One of the steps you can take to be more secure, is to create a password that allows access to your computer.

### CREATE A PASSWORD

Computer passwords are used to help identify the correct user and also prevent unauthorised use. A password consists of a string of secret characters, numbers, or words that are used to verify the identity of a user during the **authentication process**. It is used together with a username, and is designed to be known only to the user and allow that user to gain access to a device, application or website.

You can create a password in Windows 10 by doing the following:

1. Click on the *Start* button.
2. Type in *Control Panel*.
3. Open the *Control Panel*, and click on *User Accounts*.
4. Open *User Accounts* and choose *Make changes to accounts*.
5. Click on *Add a new user in PC settings*.
6. Choose *Make changes to my account in PC settings*.
7. Click or tap *Sign-in options* from the left.
8. In the *Password* area, click on the *Add* button.
9. Enter the new password correctly in both text fields, where required.
10. In the *Password Hint* field, enter something that will help you remember the password. Click *Next*.
11. Click on *Finish* to complete the password setup.

To access your computer, you need to key in the correct login name and password. You must ensure to log off when you are done with your computer so that no one else has access to your information.

#### TIPS FOR CREATING A PASSWORD

- The longer the better – a minimum of 12-characters is recommended.
- Mix it up; use variations on capitalisation, spelling, numbers and punctuation.
- Avoid names, places and dictionary words.
- Use a sentence that you will remember, for example, your name and date of birth.
- Use the first letters of each word as your password, for example, “My name is Julia Mabula and I was born on 13 March 2001!” The password would then be “MniJMalwbo13M21!” – it consists of 16 characters: letters – upper- and lowercase, numbers and symbols.



#### CAN'T REMEMBER MY PASSWORD

Should you forget your password, click on this QR code to find out how you can reset it:



<https://www.techrepublic.com/article/how-to-reset-your-windows-10-password-when-you-forget-it/>

## OTHER AUTHENTICATION METHODS

The world of computers is changing every year. Nowadays, with the touch of your finger, you can unlock your computer and phone. Businesses that are really serious about their security use fingerprint scanning, facial recognition, or an iris scanner to protect the information on their computers.

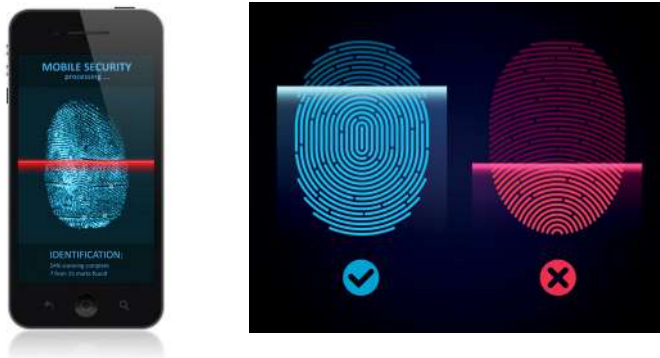

**Figure 7.10:** Authentication safety measures

### SCREEN LOCK PATTERN

Users can secure their smartphones or tablets by using a screen lock. So, every time the user turns the phone on, or wakes it up from standby mode, it requires a screen lock pattern. This can be in the form of a pin, password, fingerprint scan and nowadays, users can unlock their devices by scanning their retina.

More about the pattern:

- It is a simple pattern that is drawn with the user's finger.
- It makes the device more secure and less accessible by others.
- If you take privacy very seriously, using a pattern to lock the device can actually be handy.



#### Activity 7.3

Read the following scenario and answer the questions that follow:

The Mo-ho family used a desktop computer connected to a printer, keyboard and wireless mouse at home for some time. Mrs Mo-ho has now started her own catering business, which she runs from home and requires that she interact with foreign clients.

1. **List** one essential output device, other than a printer, that she will need to perform her duties.
2. **List** one essential input device, other than a keyboard and mouse, that she will need to perform her duties.
3. Mrs Mo-ho stores sensitive sales information on her computer. She uses a login ID, with her numeric birth date (2907) as the password to access her computer. However, she is scared that someone might crack her password and gain access to her computer.
  - a. State two ways in which she could strengthen her password.
  - b. List one example of an authentication device, which could be used as part of her computer system to gain access to her computer, as well as give her an extra layer of security.

## REVISION ACTIVITY

1. Explain briefly what is meant by the term “software”. (2)
2. The image below shows a box that you will often use when formatting paragraphs in the Microsoft Word processor.

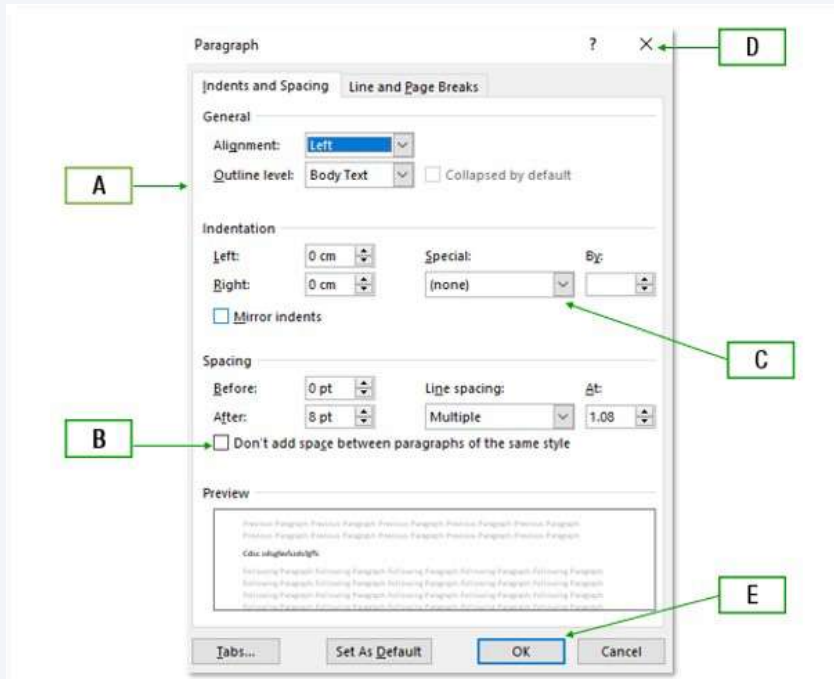

Write down the letter of the label that matches each of the following components:

- a. Dialogue box (5)
  - b. Close button (1)
  - c. Option button (2)
  - d. Check box (3)
  - e. Combo box (4)
3. What do the letters GUI stand for? (1)
  4. What is the function of a GUI? (2)
  5. Johan often uses Microsoft Paint, the *Calculator* application and the *Snipping Tool* to assist him with homework tasks. Which of the applications would he most likely use to do the following:
    - a. Resize a photograph taken with his smartphone camera
    - b. Take a screen capture of an image found on a website for a project
    - c. Convert a temperature in degrees Fahrenheit to degrees Celcius. (3)
  6. Explain the difference between application software and system software. (4)
  7. Match the number of the application software type in Column A with the letter of the example in Column B. (4)

COLUMN A	COLUMN B
1. Movie player	A. Counter strike
2. Accounting software	B. Adobe Acrobat Reader
3. Internet browser	C. VLC
4. Gaming	D. Microsoft Excel
	E. Edge
	F. QuickBooks

... continued

## REVISION ACTIVITY

... continued

8. Mention two functions of an operating system. (2)
9. Give the name of an operating system that is used for smartphones. (1)
10. Rate each of the following passwords as “weak”, “strong” or “very strong”:
  - a. N@t1onal2o19
  - b. Long2Montagu#Electric)Lego
  - c. SamHolly (your dogs’ names) (3)
11. Mention two types of access control systems that are found on smartphones other than a password or pin. (2)

**TOTAL: [29]**

## AT THE END OF THE CHAPTER

Use the checklist to make sure that you worked through the following and that you understand it

NO.	DID YOU ...	YES	NO
1.	Understand what software is.		
2.	Identify the different types of software.		
3.	Learn about the different features, advantages and disadvantages of the different types of software.		
4.	Learn about the different operating systems.		
5.	Understand what the GUI is and its different elements.		
6.	Understand the importance of PC security.		

# EXTENDED SOFTWARE CONCEPTS

## CHAPTER OVERVIEW

Unit 8.1 Types of software

Unit 8.2 System software

Unit 8.3 Licensing and licensing agreements

At the end of this chapter, you should be able to: 

- Describe system software in more detail.
- Identify the different types of system software.
- Explain the advantages and disadvantages of the different types of system software.
- Describe drivers and utilities.
- Understand the importance of computer security and software piracy.

## INTRODUCTION

We have already looked at the basics of software and the different types of software you can get. Remember, without the correct system software, the application software and programs will not function correctly on your computer.

In this section, we will look at software in a bit more depth.

## 8.1 Types of software

System software is designed to control and coordinate the tasks and functions of computer hardware. System software also allows for interaction between hardware, software and the user. You can say that system software is like the “middle man”, it allows the software and hardware to communicate, making the computer easy to work on.

Let’s look at the different types of software.

## FREWARE, SHAREWARE AND PROPRIETARY SOFTWARE

We will now take a look at the differences between freeware, **shareware** and proprietary software in the following table:

**Table 8.1:** Freeware, shareware and proprietary software

TYPE OF SOFTWARE	FREWARE	SHAREWARE	PROPRIETARY
<b>Description</b>	<b>Freeware</b> can also be called <i>free software</i> , which is copyright software that is available to you, free of charge. However, the developers or company that distributes the software keeps the rights to the software.	<b>Shareware</b> is also copyright software that is distributed for free, but only for a trial period, which notifies users that they might need to pay for it later if they want to keep using the program.	<b>Proprietary software</b> , also known as <i>closed-source software</i> , is where the source code is not given to the public or to the user. In other words, it still belongs to the distributor or developer, even if you have bought the program.
<b>Examples</b>	Gmail, Firefox, Skype, Adobe Acrobat Reader, etc.	Deposit photos, Google Music, BitTorrent, etc.	Adobe Flash Player, Google Earth, WinRAR, Microsoft Office, etc.
<b>Advantages</b>	The main advantage of freeware is that it is free as well as easily available.	The advantage about shareware is that it gives the distributor exposure, while at the same time, gives users the time to decide whether they want to spend money on the program or not.	Proprietary software, on the other hand, is more user friendly and stable, and the technical support is easier to access.
<b>Disadvantages</b>	It can contain <b>viruses</b> and Trojan horses that can affect the way in which the computer performs.	The main disadvantages are that it cannot be modified and may be a cut-down or temporary version.	The only downside is that this software costs money and if there are any technical issues, you will have to wait for a developer to address the problem.



### Something to know

Keep in mind that there are safety precautions you should know about when **downloading** software for free or even if you are paying for it. Nothing stops the developer from bundling the software with **malware** (virus, worms or spyware) and still make you pay for it. There is also a lot of freeware that is completely useless or ineffective. Always be aware of the importance of practicing good software safety so that you can choose the best software for your needs.

## OPEN-SOURCE SOFTWARE

When the program is developed, the developers must decide whether they want to make its code proprietary or **open-source software**. The following table explains more about open source software.

**Table 8.2:** *Open-source software*

OPEN-SOURCE SOFTWARE	
<b>Definition</b>	Open source software has a source code that is available to the public or anyone that wants to use it. It also allows the user to change or modify the code if need be. You can also distribute this type of software to anyone and for any purpose.
<b>Advantages</b>	<ul style="list-style-type: none"><li>• It is free and you do not need to pay for using it, which saves you money.</li><li>• Since the source is available to anyone, the public can collaborate and fix bugs.</li><li>• Collaborators can improve the performance, or even add features.</li><li>• It is high-quality software that is well designed.</li></ul>
<b>Disadvantages</b>	<ul style="list-style-type: none"><li>• Open software might not be as user friendly especially to unskilled users.</li><li>• Difficult to find proper technical support.</li><li>• Difficult to find drivers for some devices.</li><li>• You can be prone to viruses and other cyber attacks.</li></ul>
<b>Examples</b>	Linux Kernel, Firefox, Gimp, etc.



OPEN-SOURCE OR  
PROPRIETARY  
SOFTWARE



[https://www.youtube.com/  
watch?time\\_continue=  
5&v=2q91vTvc7YE](https://www.youtube.com/watch?time_continue=5&v=2q91vTvc7YE)



### Something to know

If the device drivers need an update and the manufacturer is still around, then the drivers are usually listed on their web page.

Sometimes, the manufacturer might be out of business and you can find out-of-date, or even obsolete drivers on third-party websites that specialise in this type of business.

You can update the Windows system with the latest software. Other than a few drivers and Microsoft built-in programs, there is not much to a Windows update, and this is where driver and software update tools come into play. These utilities keep the Windows, PC, laptop or tablet up to date on a regular basis.

We will now learn a bit more about drivers and utility programs.

## DRIVERS

Device drivers, more often known as drivers, are a group of programs that allow the hardware and the operating system to communicate with each other. Each hardware device has a specific driver that must be installed on the computer to which it is connected.

If the wrong driver is installed, if the driver is outdated, or if there is no driver installed at all, the hardware may not work properly, or it may not work at all. If you are using Microsoft Windows and there are compatibility issues, open the *Device Manager* to see what is happening.

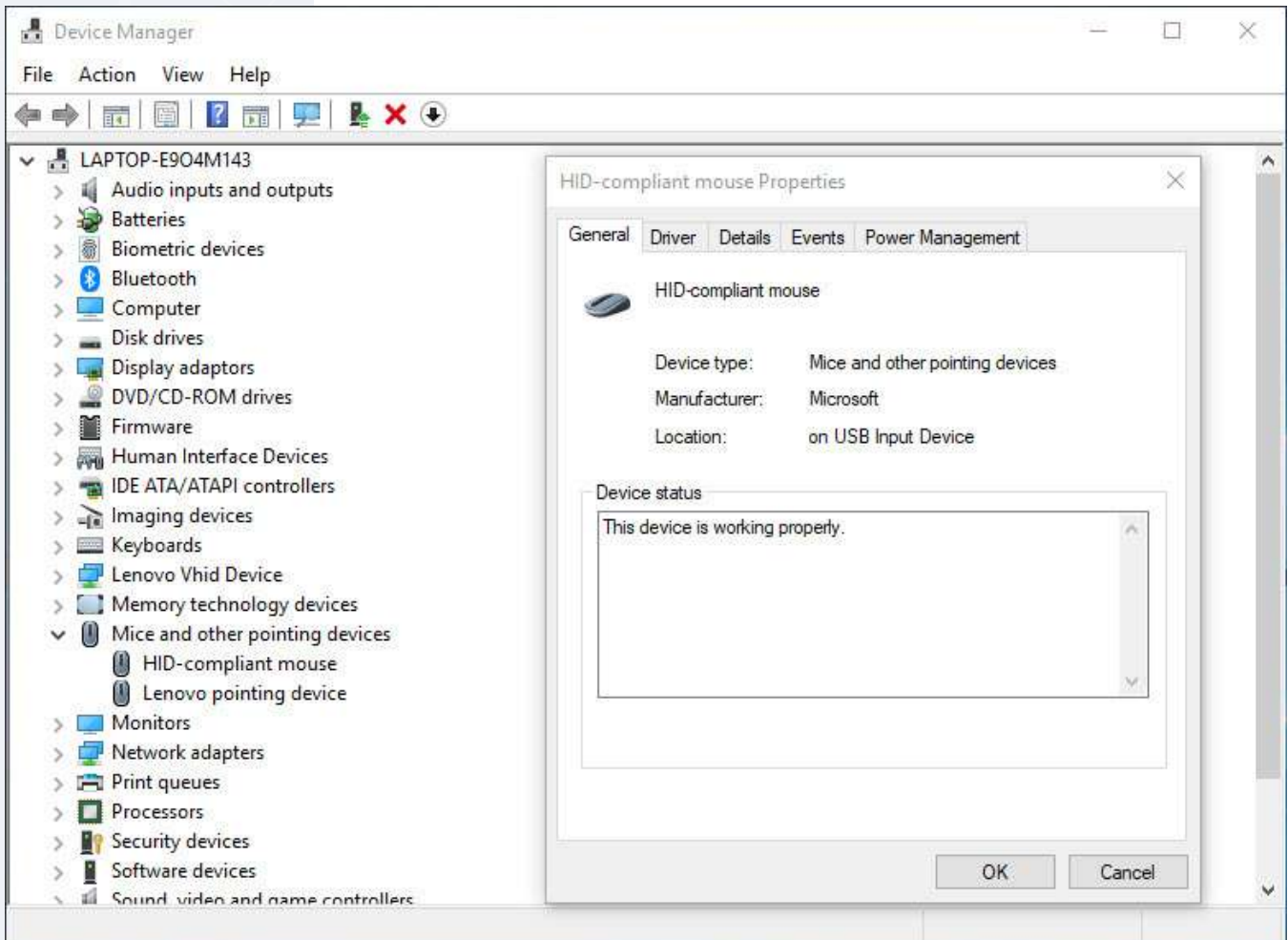

Figure 8.1: Device Manager

## AUTOCONFIGURATION OF DEVICES

Autoconfiguration means to add devices to a computing device, without the need of user-intervention or software-configuration programs. In other words, you can connect the device to the computer, and the device will automatically install the drivers and then configure it in the system. The two types of autoconfiguration have been explained below.

### PLUG AND PLAY

Plug and play, also known as PnP, is a term used when an operating system recognises a device and it installs the device driver automatically. These devices allow the user to use the device immediately after it has been connected to the computer. Hardware examples would include keyboards, mice, monitors, etc.

### HOT SWAPPABLE

This is the ability to plug a device into a computer while it is switched on. It also allows you to use the device without having to switch off the computer. An example of this type of device would be a mouse. A mouse is a type of **plug-and-play device**, after plugging it in. It will work immediately.

## UTILITY PROGRAMS

Utility programs or utilities allow you to perform computer management and maintenance tasks. These programs are much smaller in size compared to other software programs and can come packaged with the operating system, or installed at a later stage. Examples of utility programs are back-up software, disk clean-up, compression programs and so on.

*Backup software* is a program that copies data to a different location for in case you lose or delete the original data. You can then restore this data from the back-up copy. Nowadays, people actually back up their data on flash disks, hard drives and even the cloud.

### Compression programs

*Compression programs* are used to compress or decompress files. In Windows operating systems, examples of programs that decompress and compress files would be 7Zip, WinZip and WinRAR.

*Disk Clean-up* is a program that removes unnecessary files and temporary files. This can help speed up the performance of your computer. In order to clean up your computer space, you can do the following:

1. Click on the *Start* button.
2. Type in *Disk Clean-up*.
3. Click on *Disk Clean-up*. It will then show you the suggested files to delete (refer to Figure 8.2).
4. If you agree with the evaluation, click on *Clean up system files*. (Refer to Figure 8.2.)



### CLOUD STORAGE

Have a look at this article to see how cloud storage works:

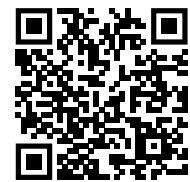

<https://computer.howstuffworks.com/cloud-computing/cloud-storage.htm>

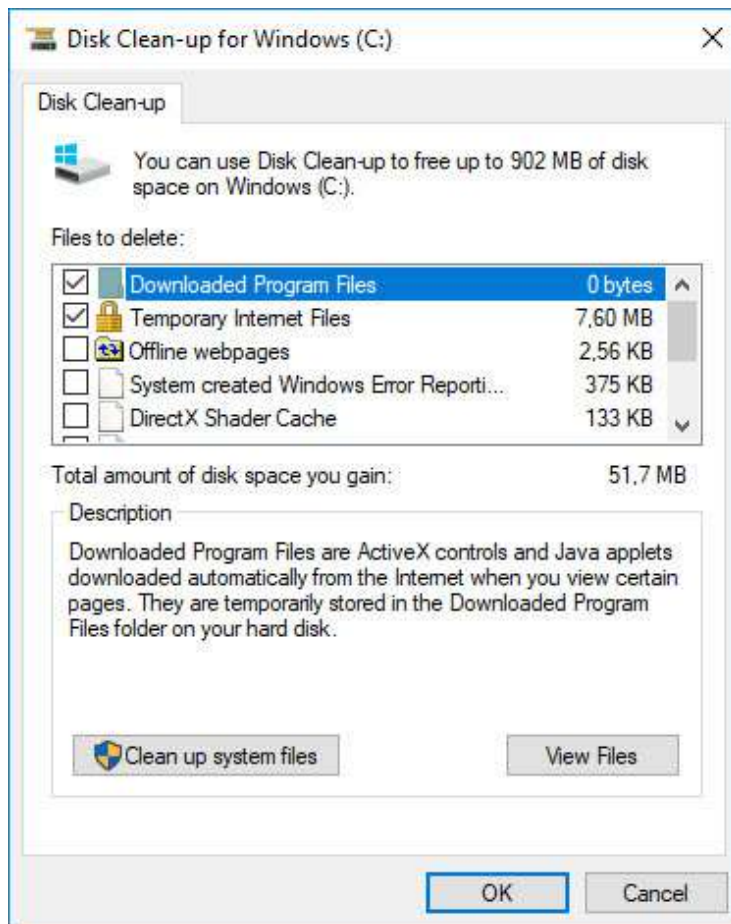

**Figure 8.2:** *Disk Clean-up*

Using *Disk Clean-up* at least once a month can help improve the performance of your computer!

## 8.3 Licensing and licensing agreements

### SOFTWARE LICENSING AND LICENCE AGREEMENTS

When users pay for proprietary software, they pay for the rights to use it while the software still belongs to the developer. When you install proprietary software, you have to agree to terms and conditions in the licence agreement. This is an actual agreement and can contain information, such as:

- The software cannot be modified or changed
- Copies of the software cannot be made and distributed
- The software cannot be installed on more than one device

The licence agreement is better known as the end-user licence agreement (EULA) and has three types of agreements:

1. **Single-user licence:** This means that you can install the software on only one computer or device.
2. **Multi-user licence:** This means you can install the software on several devices or computers, which will be indicated in the licence agreement.
3. **Site licence:** This licence allows you to install software on a number of computers at the same site. This licence may be unlimited, but may also be limited to a certain number of users at the same time. This type of licence is often used by businesses and schools.

### CREATIVE COMMONS

This is a set of copyright agreements that allows the public to freely distribute and use copyright work. It is used when a developer wants to give people the right to share, use and build upon a program that they have created. Creative commons can be abbreviated to CC and there are several CC licences that allow the user to do the following:

- Copy the work – i.e. you can download, copy and photocopy the content that is required.
- Distribute the content, for example to teachers, schools and other educational purposes.
- Communicate the content, for example make it available on the school network.

Examples of organisations that use the CC licence are Wikipedia, some YouTube channels, Boundless, etc.

### SOFTWARE PIRACY

Piracy is the illegal copying, distribution or use of software. Illegal copies are sold at a cheap price. When illegal copies are made and distributed in the form of CDs or DVDs or another storage medium, it is called software piracy. There are different types of software piracy:

- **Softlifting:** When a software program with a legal licence is installed or copied with the main purpose of providing it to multiple users, rather than to sell copies for profit.
- **Client-server overuse:** When more users, as stipulated in the licensing agreement, are using a central copy of a program at the same time.
- **Hard-disk loading:** This happens when illegal copies of software are loaded onto the hard disks of new computers to make the purchase more attractive.



### Something to know

According to the *Business Software Alliance* (BSA), about 36% of software that is used is pirated. Software piracy causes a lot of monetary loss for developers, making the legal copies more expensive.

- **Counterfeiting:** The illegal duplication, distribution and/or sale of copyright material with the intent of imitating the copyright product.
- **Online piracy:** When proprietary software is downloaded from the internet.



### Activity 8.1

1. Define the following types of software:
  - a. Freeware
  - b. Shareware
  - c. Open source
  - d. Proprietary software
2. Describe how one would go about using proprietary software, without having to spend much money. Motivate your answer.

One of Mr Itek's children knows his friend has software for Microsoft Word. He wants to copy the software, then install it on their home computer.

3. Is Mr Itek doing the right thing? Motivate your answer.
4. How would you categorise the way in which Mr Itek's friend intends on using the software?

### REVISION ACTIVITY

1. The table below is comparing freeware, shareware and proprietary software. Make a copy of the table in your workbook and fill in the headings, as well as the missing information. (12)

TYPE OF SOFTWARE			
<b>Description</b>	Known as "try before you buy" software		
<b>Example</b>		Gmail	
<b>Advantage</b>			Technical support is freely available
<b>Disadvantage</b>			

2. Fairiza purchases a laptop that she can use to work on assignments for her course at university. The laptop was supplied with the Windows 10 Home operating system.
  - a. She obtained a copy of Microsoft Office 2016 from a friend and installed it on her laptop. Explain why she should NOT do this. (2)
  - b. If she wishes to continue using Office 2016, what type of licence does she need? (1)
  - c. When she updates Office 2016 with a valid licence, she is asked to acknowledge that she has read the EULA. What does EULA stand for? (1)  
If she cannot afford to purchase a licence from Microsoft, she could install an Open Source office suite.
  - d. What is open-source software? (2)
  - e. Give an example of an Open Source office suite that she could use. (1)
3. You have purchased a new printer. When you connect the printer to your computer for the first time, you have to install a printer driver that is on a CD provided with the printer.
  - a. What is a driver? (1)

... continued

## REVISION ACTIVITY

... continued

- b. Write down the missing words:  
When you plugged in a new wireless mouse for the first time, the driver was installed automatically by the operating system. This is known as plug and play, or \_\_\_\_\_.
- c. What is a hot swappable device?
4. Mention two utility programs that are part of the Windows 10 operating system.

(2)

(2)

(2)

**TOTAL: [26]**

## AT THE END OF THE CHAPTER

Use the checklist to make sure that you worked through the following and that you understand it.

NO.	DID YOU ...	YES	NO
1.	Learn about the different types of system software.		
2.	Understand the advantages and disadvantages of open-source software.		
3.	Learn about drivers and utility programs.		
4.	Understand what auto-configuration of devices is and how it works.		
5.	Understand the importance of computer security.		
6.	Learn about the different ways in which software can be pirated.		

# INTRODUCTION TO NETWORKS AND NETWORKING CONCEPTS

## CHAPTER OVERVIEW

<b>Unit 9.1</b>	Concepts used in networks
<b>Unit 9.2</b>	Uses of networks
<b>Unit 9.3</b>	Social implications: Networks

At the end of this chapter, you should be able to: 

- Explain the different concepts used in networks.
- Understand how networks are used.
- Discuss the advantages and disadvantages of networks.
- Identify the social implications that are associated with networks.

## INTRODUCTION

A computer network consists of two or more computers and other hardware devices that are linked together through **communication channels** to share electronic communications and resources, such as printers with various users.

### Something to know

The Semi-Automatic Ground Environment (SAGE) computer system was invented by two MIT professors during the 1950s and became operational in 1961. Because of America's size, the speed of the military attack planes and the possibility of nuclear attacks by the Russians, the US military decided that they needed an air-defence system that would identify and intercept enemy planes before they could do any damage.

SAGE was, therefore developed, using techniques learned from World War II radar development. Weighing over 250 tonnes, SAGE was one of the largest computers ever built and consisted of 23 bunkers all over the US and one in Canada; each having a SAGE computer that could track 400 planes. As it consisted of a network of long-distance communications technology through landlines and ground-to-air radio links and **interactive** display terminals, it could differentiate between enemy and friendly planes by keeping track of flight plans. What made SAGE so extraordinary, is the fact that it was the first network-based computer system, laying the foundation for the entire internet age.

In this chapter, you will learn about networks, the different concepts used in networks, and the advantages and disadvantages of networks. You will also learn how to use networks in an ethical and correct way.

## 9.1 Concepts used in networks

Looking at the definition of a computer network in the “Introduction”, you will remember that a computer network consists of two or more computers and hardware devices linked together through communication channels to share electronic communications and resources with various users.

In computer networks, computing devices are called **nodes** and share data with each other through **data links**. These links are sent over cable media such as wires, optic cables, or wireless media such as Wi-Fi. The connected computers also share resources, such as access to printers, with the most common resource being the internet.

There are two common types of networks:

1. **Home Area Network (HAN):** A HAN is a very small network that usually covers a single home or home office.
2. **Personal Area Network (PAN):** A PAN is similar to a HAN, but even smaller! It refers to a network that is built for a single person and contains all the devices connected to this network.

Most organisations, such as schools and businesses, have computers that are connected to a central computer called the **network server**. This server is the main computer that manages the communication between all the other computers on the network. A **network client** refers to the hardware or software that can access services made available by a server.

**Network administrators** are the people that are part of a technical support team, and who can modify and change the network according to the organisation’s needs. The administrator can, for example, remove computers from the network and restrict access to users, preventing them from having access to confidential information.

There are various devices helping in the communication between nodes, for example:

- **Switches:** The main purpose of switches is to share information between specific computers without involving the other computers in the network. This means that these computers can continue doing what they are doing. Looking at the following diagram, you will see that by using a switch, Computer A sends a message to Computer B, without the other computers seeing the message. Those computers can send other messages at the same time and without interference.

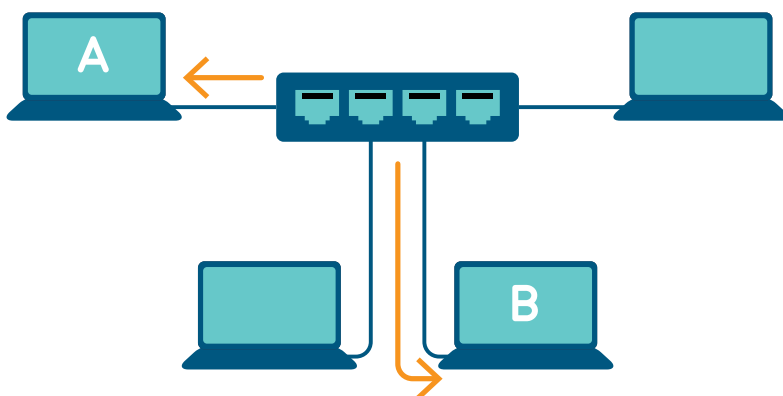

**Figure 9.1:** Messages sent using switches

- **Routers:** Routers do most of the hard work in a network as they make the decisions about all the messages that pass through the network. This means that they analyse each piece of data and protect information from security threats through a firewall. Routers also choose the route for the data to travel and decide which computer gets priority.
- **Wireless access points:** These points allow devices to connect to a wireless network without cables. It can also give useful data about the devices on the network.



### Activity 9.1

1. Write the correct answer to the questions below in your book:
  - a. In computer networks, computing devices are called \_\_\_\_\_?
    - A. Computers
    - B. Nodes
    - C. Modems
    - D. Switches
  - b. A PAN is a \_\_\_\_\_.
    - A. Network that operates in a large area, such as across a country
    - B. Network built for a single person connecting all the devices
    - C. Very small network that usually covers a single home
    - D. Network that operates in a small area, such as a house, school or office
  - c. A switch is a device that \_\_\_\_\_.
    - A. Shares information between specific computers without involving the other computers in the network
    - B. Makes the decisions about all the messages that pass through the network
    - C. Connects a computer or network to the internet
    - D. Allows computing devices to connect to a wireless network without cables
  - d. Ethernet \_\_\_\_\_.
    - A. Is a set of rules that define the way in which two networking nodes can communicate
    - B. Is a type of data link protocol that defines the types of cables and connections used to wire computers, switches and routers together
    - C. Connects a computer or network to the internet
    - D. Can remove computers from the network and restrict access to users
  - e. The people who can modify and change the network settings are called the \_\_\_\_\_.
    - A. Network technicians
    - B. Computer nerds
    - C. Network administrators
    - D. Gamers

## 9.2 Uses of networks

So far, you have learned that networks can be used in a variety of environments; from schools to businesses to homes. These uses (aims and objectives) can be grouped into the following four main categories:

1. Sharing resources
2. Connecting people
3. Organising information
4. Access to entertainment

In this section, we will look at the different uses of networks, as well as their advantages and disadvantages.

### AIMS AND OBJECTIVES OF NETWORKS

Networks have become something that we can barely live without. In this section, we will take a look at some of their main uses.

#### SHARING

One of the primary objectives of a network is to *share information*.

Although networks are designed to share information, they do much more than that; they also *share the resources* linked to the computers on the networks. This includes access to the internet, files, hardware, people and money.



**Figure 9.2:** *People connected to networks*

The most common reason for creating a home, school, or office network is to provide all the computers connected to that network, access to the internet. In South Africa, the internet is an expensive resource. By sharing the internet between many people, it becomes slightly more affordable and people who would previously not have had access to the internet, can now gain access.



#### Something to know

According to the United Nations (UN) agency that oversees international communications, more than three billion people all over the world are using the internet. This number increased from 738 million in 2000, to 3.2 billion in 2015. This is fantastic, right? So now, people from South Africa can send a file, text or image from their computers to someone anywhere in the world with just the click of a button.

The second most common reason for creating a home or office network is to provide access to shared files. In many offices, a central computer or server is used to store shared files and anyone who needs access to these files, can access them through the server.

Homes and offices also use networks to share hardware, such as printers and scanners. This allows many people to use a single printer or scanner without too much hassle or causing any problems.

### NETWORKING TO SUCCESS!

At some point you must have come across the terms *cloud*, *cloud computing*, or *cloud storage*, but what exactly is this cloud?

In simple words, the cloud is the internet and refers to all the things you can access remotely through the internet. If a file or folder, or pretty much anything that is stored on the cloud, is stored on internet servers and not on your computer's hard drive.

People all over the world use the cloud, because it is reliable and convenient. It is easy to store and share files, as well as back-up data. If, for example, you have used an email application, such as Gmail or MWeb mail, you have already used the cloud!

The nice thing about the cloud is that even if your computer crashes, you can still access your information if you have previously backed it up on the cloud.

Have a look at the video link on the left to understand more about cloud computing, it is worth a watch!

When we think of resources, remember these are not just restricted to your computer, but can also extend to real-world resources, for example, people and money. Should you encounter a problem, you can get advice from experts all over the world by asking for advice on the internet. Banking sites, investment sites and **crowdfunding** websites, such as GoFundMe.com, can provide you with access to money.

## ORGANISING INFORMATION

Computer networks not only provide access to information; they also help people to organise information. This could be something small, such as a Google Calendar event where people work together to organise a single event. It can be something complex, such as Google Maps that gives people driving directions in more than 240 countries and covers over 64 million kilometres of road (that is about 83 trips to the moon and back).

By recording information in a central location on a network, people can work together to organise it in a way that is useful and understandable.

## CONNECTING PEOPLE

Another important use of networks or telecommunication networks is to connect people. This can be through emails, video calls on your computer, social networks such as WhatsApp or other instant messaging services (IMs). Using computer networks makes this possible and allows people from anywhere in the world to communicate with one another.



### WHAT IS THE CLOUD?



[https://www.youtube.com/watch?time\\_continue=30&v=gu4FYsFeWqg](https://www.youtube.com/watch?time_continue=30&v=gu4FYsFeWqg)



**Figure 9.3:** *Using the network to communicate*

## ACCESS TO ENTERTAINMENT

A final important use of networks is to give people access to entertainment. In the past, entertainment was an expensive luxury that only a few people could have. Today, things are different; the average person with an internet connection can watch and listen to a wide variety of films and albums on the internet. In fact, internet access provides access to an almost unlimited amount of entertainment; from books to read, music to listen to, watching the news, or chatting with friends.

## ADVANTAGES AND DISADVANTAGES OF NETWORKS

Networks also pose potential advantages and disadvantages. The following table looks at the risks and benefits that come with networks.

**Table 9.1:** *Comparison of the advantages and disadvantages of connecting to a network*

ADVANTAGES	DISADVANTAGES
<ul style="list-style-type: none"> <li>• <b>Makes communication easier:</b> People can communicate from all around the world through the network.</li> <li>• <b>Information transfer:</b> Data and information can be easily transferred or copied from the one computer to another.</li> <li>• <b>Access to hardware devices:</b> In a network, access to a single printer or scanner is easily available to many people at the same time.</li> <li>• <b>Software installation:</b> Software applications can easily be installed or upgraded from one central location.</li> <li>• <b>Central storage:</b> Information and data can be stored in one place (central location).</li> </ul>	<ul style="list-style-type: none"> <li>• <b>Online crimes:</b> Can expose a person to online crimes, such as identity theft, credit-card theft and scams.</li> <li>• <b>Viruses:</b> Viruses can easily be transferred from one computer to another through the network.</li> <li>• <b>Security and privacy concerns:</b> Since computers are all connected in a network, people can try to access private and restricted information using the network.</li> <li>• <b>Maintenance:</b> A network administrator has control over the network, and administers and manages usage.</li> </ul>



## WHERE DOES THE INTERNET COME FROM?



[https://www.youtube.com/watch?time\\_continue=17&v=jKA5hz3dV-g](https://www.youtube.com/watch?time_continue=17&v=jKA5hz3dV-g)

Everything has its advantages and disadvantages; it is just the way life goes. However, the table on the previous page is just a list of potential advantages and disadvantages; the way in which you use the network is the only way you get affected, positively and negatively. For example, if you want to learn how to bake, speak a new language or even build your own treehouse, there are always free resources to teach you a new skill. But at the same time, the downside is that the internet also has a dark side. So, what you get from a network depends on what you are looking for and your ability to use it.

## THE INTERNET: THE NETWORK OF NETWORKS

We have spoken a lot about networks and how networks enable telecommunication, but what exactly is the driving force behind that? The internet is a global network made up of many, many computers (we are talking about billions of computers) and other electronic devices. You can access almost any information, communicate with anyone anywhere across the world and do much more, just by connecting a computer or electronic device to the internet.

There are also a lot of other things that you can do on the internet. As you know, one of the best things about the internet is how quick it is, and how quickly you can communicate with anyone anywhere in the world. You can email and use social media, you can pay bills, do online shopping, listen to music, meet new people, or even learn a new skill.

## 9.3 Social implications: Networks

There are legal, ethical and security aspects you should take note of with regards to networks. These include viruses, licensing contracts, adhering to the user policies and ownership of electronic material. In this section, we will look at each of these aspects in some more detail.

### VIRUSES

This is anyone's worst nightmare. Without a proper antivirus program installed, you will be prone to getting a virus. Viruses can be transferred through flash disks, or through other computers in a network. Antivirus programs help to protect your software, data and PC from possible threats.

Read through the following case study and discuss the questions in small groups.



#### Case Study 9.1

#### Viruses are dangerous

Viruses can be very dangerous. In 2000, there was a virus called the "ILOVEYOU virus". Although, by today's standards, it is a pretty silly virus, it still is one of the most well-known and destructive viruses of all time. It even made the Guinness World Record for being the most "virulent" virus of all time. It overwrote both system and personal files, and spread itself over and over again.

The virus was a worm that was downloaded by clicking on an email attachment called "LOVE-LETTER-FOR-YOU.TXT.vbs". Although people did not know the person sending the email, or the fact that it made headlines around the world, people still clicked on it, activating the virus and attaching it to all their emails.

In the end, the two programmers who developed the virus were caught. Unfortunately, they were set free as there were no laws against writing **malware** at that time.

Discuss the following in pairs.

1. Will you open an email sent to you from someone you do not know? Motivate your answer.
2. How will you know that something (an email, website, etc.) is dodgy? What would you do in such a case?
3. What can you do to ensure that you do not get a virus like that?

### LICENSING CONTRACTS

An organisation cannot just share software over a network, it must purchase a network licence; otherwise, it is illegal. A network licence lets more than one user at a time access the software on the server.

Depending on the number of computers attached to the network, the network licence fee will be different. A legal agreement that lets users install software on a number of computers is called a **site licence**.

## USER POLICIES

Organisations, such as schools and businesses, normally have an *acceptable computer usage policy* in place. This policy stipulates how computer equipment should be used and prevents anyone from accessing restricted information or data on the network. If a person breaks the rules, it is regarded as a serious offence and the person could get into a lot of trouble.



### Something to know

Believe it or not, plagiarism is actually very old; it just was not frowned upon then as it is now. Shakespeare is known to have “borrowed” a lot from other writers. However, back in the day, plagiarising was actually seen as a compliment.

## OWNERSHIP OF ELECTRONIC MATERIAL

Accessing data that is not your own is regarded as a criminal offence. For example, you should not change or access the data on the computer of another network user without getting his or her permission. **Plagiarism** is when you illegally copy information from the internet, or from any other published material and say that it is your own, unless you obtained permission to use it.



### Case Study 9.2

#### Plagiarism in music

The “Blurred Lines case” made the news when Pharrell Williams and Robin Thicke were accused of copying Marvin Gaye’s music to create “Blurred Lines”. This was the most popular song in 2013. Marvin Gaye’s children were awarded US \$7.4 million since the jury was in favour of their claims.

Answer the following questions on your own.

1. Why was it seen as plagiarism? What did they do wrong?
2. What do you think about plagiarism – should the law continue working against plagiarism? Why or why not?



### Activity 9.2

Miss Furry wants to network the computers and other hardware devices in her office. She shares a printer with three other people. She was told she would need a switch, router and a **modem**.

1. Define a computer network.
2. Answer the following questions with reference to the scenario above:
  - a. Give two advantages of creating a network for Miss Furry.
  - b. List one type of hardware device that she can connect to the network.
  - c. Is this hardware (your answer for question b above) an input or output device? Motivate your answer.
  - d. Briefly explain how Miss Furry can use the network to communicate to others.
3. Explain what the internet is.
4. An organisation cannot just share software over a network.
  - a. Provided that this statement is true. What can an organisation do to share software?
  - b. Briefly give a description of a network licence.
  - c. Explain what a site licence is.

## REVISION ACTIVITY

1. What is a computer network? (4)
2. Your school is planning to network its 25 stand-alone computers. (2)
  - a. List two advantages to the school of installing a network. (2)
  - b. List two disadvantages to the school of installing a network. (2)
  - c. Apart from a network server and cabling, what other hardware would the school need when installing the network? (2)
3. The diagram below shows a simple network. Use the diagram to answer the following questions:

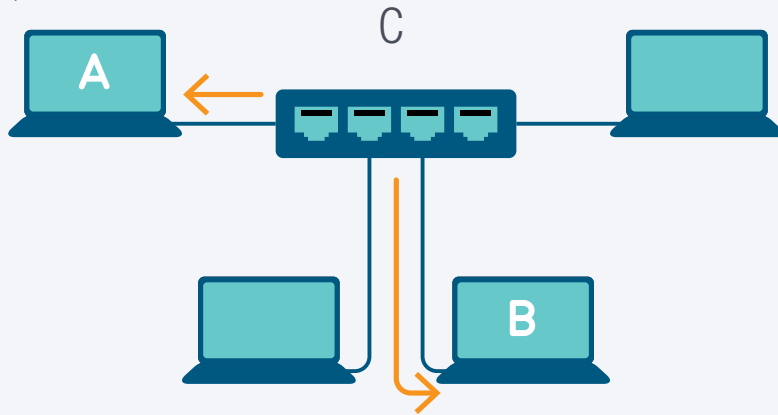

- a. What are A and B? (2)
- b. What is device C? There are two possible answers. List both of them. (2)
- c. Which device is receiving information? (1)
4. "The internet is an example of a computer network." Is this statement true or false? (1)
5. Reinet is doing research for her PAT. She finds an interesting website on the internet. When she prepares her final presentation, she copies large sections of text from the website and pastes them into her presentation.
  - a. Is Reinet allowed to copy sections of text into her presentation and pretend that she wrote it herself? Give a reason for your answer. (2)
  - b. Give one word for what Reinet has done. (1)

**TOTAL: [19]**

## AT THE END OF THE CHAPTER

Use the checklist to make sure that you worked through the following and that you understand it.

NO.	DID YOU ...	YES	NO
1.	Understand the different concepts that are used in networks.		
2.	Learn about the different uses of networks.		
3.	Learn about the advantages and disadvantages of networks.		
4.	Understand the legal, ethical and security aspects regarding networks.		

## TYPES OF NETWORKS: PAN/HAN

CHAPTER OVERVIEW 

Unit 10.1 PAN/HAN

Unit 10.2 Creating a PAN/HAN

At the end of this chapter, you should be able to: 

- Discuss the different types of networks.
- Identify the advantages and disadvantages of PAN.
- Distinguish between a modem, router and switch.
- Identify the hardware and software required to connect to the internet using a PC.

## INTRODUCTION

In the previous chapter, you learned about the different concepts used in networks. In this chapter, we will look at PANs and HANs, and how they are created, their advantages and disadvantages, as well as the different network devices required to create a network.

There are different types of networks. For ease of reference, we have arranged them in the following list, according to their size – i.e. from the smallest to the largest network.

1. Personal area network (PAN) and home area network (HAN) as the names state, are both used in small areas, such as home or small office environments.
2. **Local area network (LAN)** or **wireless local area network (WLAN)** are used in bigger offices and in schools.
3. **Wide area network (WAN)** connects more than one LAN in different places, for example, cities or buildings, into one big network.

Figure 10.1 shows the different types of networks.

Networks can be categorised according to their size and distance covered. As you can see, the WAN is the largest network with the internet being the most popular WAN.



**Figure 10.1:** Types of computer networks

Although all these networks may sound the same, they are quite different. In Grade 10, you will focus on the difference between a HAN and a PAN.

## WIRED AND WIRELESS NETWORKS

Before looking at HANs and PANs, you first need to understand the difference between a wired and a wireless network.

A *wired network* is a common type of network and uses **ethernet cables**, or fibre-optic cables to transfer data between computers that are connected to the network.

*Wireless networks* allow many devices to connect to the same internet connection, as well as to share files and other resources. It refers to a network where the devices are connected via radio- or microwaves, and not through physical cables.



### Something to know

The internet is the biggest network in the world. The funny thing is that no one actually owns it and at the same time, lots of people own it. Confusing, right? If you think of the internet as one entity, no one owns it, but at the same time, the internet is made up of small little parts and each of these parts has an owner. From this perspective, lots of people and organisations own the internet.

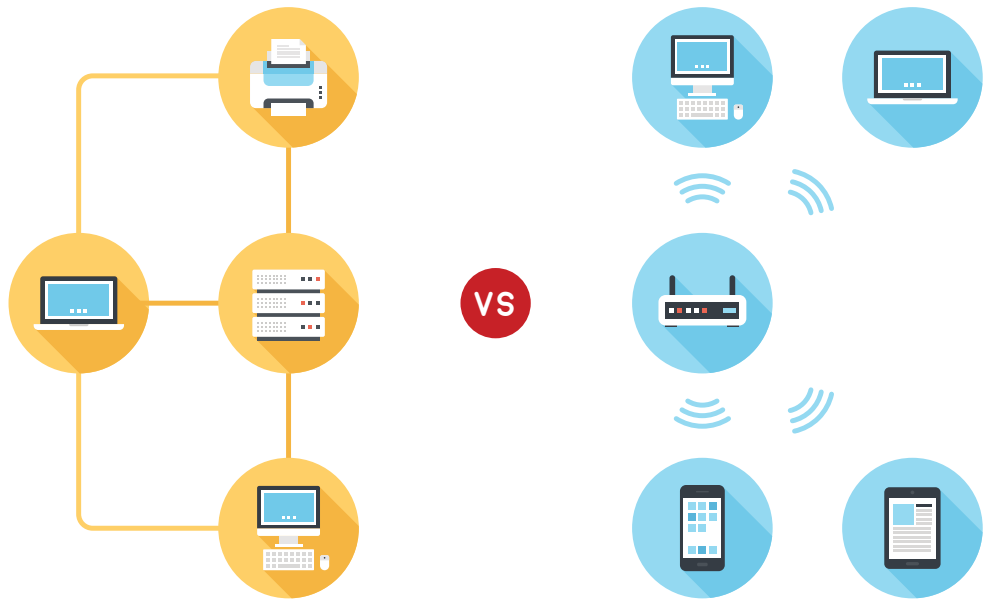

**Figure 10.2:** Comparison between a wired network (left) and wireless network (right)

## HANS AND PANS

### HAN

As the name suggests, a HAN is a very small network that usually covers a single home. Any device that is connected to this network will be able to share resources, for example the internet, smart appliances, printers, smart meters and even some security systems.



**Figure 10.3:** Example of a home network, where a computer, Smart TV, and a phone are all connected to one small network

It allows the computers on the HAN to communicate with each other directly and to transfer files between the computers, send messages, or even play LAN games. HANs can be both wired or wireless networks.

## GETTING THE MOST OUT OF YOUR SMART DEVICES

Jenny stays upstairs in a two-storey house. The printer is in the study downstairs, and even though it is good exercise to go downstairs with a flash disk and connect to the main computer to print something, it is still time consuming.

So, Jenny's dad made a plan. Since they have a wireless printer, it has the capability of connecting directly to the home network. He installed and connected the printer wirelessly to each computer in the house. Now Jenny can just print whatever she needs from her room and fetch the printed document later on. This is an example of how convenient a home network is.

## PAN

A PAN is like a HAN, but even smaller! It refers to a network built for a single person and contains all the devices connected to this network. This can include all devices connected on most networks, for example a computer, smartphone and printer. It can also include personal devices, such as Bluetooth keyboards, Bluetooth earphones and smartwatches. Unlike LANs and HANs, all devices on a PAN do not have to be connected using an **IP address**. Some devices can be connected over a Wi-Fi network, while others might connect using Bluetooth, or even USB.

For example, when the iBooks application on the computer knows which page you last read, it is because of the PAN. Those devices are connected and “talk” to each other; they are basically synced to each other. Another example is the fact that your smartwatch can tell you of any messages, emails or incoming calls while your phone is charging.

The goal of a personal network is to make the user's life easier by allowing individual devices to communicate directly with each other.

## THE FUTURE OF WEARABLE DEVICES

Now that you understand a little about PANs, let's see how this goes with fitness. Whether you are wearing an Apple watch, a FitBit, or heart-rate monitor, these devices can all connect and speak to each other. They all measure different things; from the calories you burn, to your sleep patterns and how many steps you took in a day, and much more. These measurements are then communicated to your phone or smartwatch, creating a little report on your fitness statistics. This type of PAN for the fitness industry was created by Dynastream and is called ANT.

## PAN VERSUS HAN

As can be seen in the following table, both networks have various advantages and disadvantages.

### THE ADVANTAGES AND DISADVANTAGES OF PAN

The following table shows the different advantages and disadvantages of a PAN.

**Table 10.1:** *Advantages and disadvantages of PAN*

ADVANTAGES	DISADVANTAGES
<b>Space saving:</b> PANs do not require extra wire or space. To connect two devices, for example a wireless mouse and a laptop, all you need is Bluetooth.	<b>Distance:</b> Because there is a limitation of 10 metres, this makes it difficult for sharing information and data over long distances.

... continued



ADVANTAGES	DISADVANTAGES
<p><b>Easy to use:</b> It is easy to use and no complicated setup is required.</p> <p><b>Portable:</b> You can move these devices easily as they do not have a whole bunch of wires that come with them.</p> <p><b>Reliable:</b> This type of network is reliable and stable for the devices within ten metres of the network.</p> <p><b>Secure:</b> Files and information shared on this network can only be accessed by authorised people.</p> <p><b>Synchronisation:</b> You can synchronise as many computing devices, where you can download, upload, or exchange information between the devices.</p>	<p><b>Costly:</b> PAN only makes use of digital devices, and these types of devices are expensive, for example, laptops, smartphones, smartwatches and many more.</p> <p><b>Slow data transfer:</b> The use of Bluetooth to transfer files has a slow transfer rate compared to other types of networks, such as LANs.</p> <p><b>Health issues:</b> In some instances, PAN uses microwave signals in digital devices that can have a negative effect on the human brain and body.</p>

### ADVANTAGES AND DISADVANTAGES OF HAN

The following table shows the different advantages and disadvantages of a HAN.

**Table 10.2:** *Advantages and disadvantages of HAN*

ADVANTAGES	DISADVANTAGES
<p><b>Accessibility:</b> Allows several users to be connected to the same internet connection.</p> <p><b>Resources:</b> Resources, such as printers, faxes and files can be shared over the same network.</p> <p><b>More economical:</b> Because several users can use the same hardware and internet, this reduces the costs of these things.</p>	<p><b>Internet:</b> Sometimes, if someone is downloading a big file from the internet, this can slow down the internet speed drastically for other users.</p> <p><b>Security:</b> Sometimes, if your home network is not secure, a person that lives close by can have access to files and folders on your network, so a password is necessary.</p> <p><b>Costly:</b> Buying all the equipment required, depending on the number of computing devices that must be connected to the home network, could be costly.</p>

## 10.2 Creating a PAN/HAN

In the past, home networks were not so popular. Most families did not need, or could not afford more than one computer. Today, this is not the case; people use their computers for school work, shopping, downloading videos and music, watching movies, instant messaging and so on.

So, having one computer in a household is not enough anymore and multiple computers or computing devices are becoming more of a necessity than a luxury.

### REQUIREMENTS

There are several options to look at when creating a network in your household. This section will look at what to keep in mind when creating home networks and what types of hardware are needed to create and protect your home network.

### INTERNET INFRASTRUCTURE

Any computer that is connected to the internet is part of a network. This can be from the 100 computers connected in an office, to just the one in your home. For example, at home you can connect to the internet using a modem. The modem dials a local number that connects to an **internet service provider (ISP)**. The ISP is the term used for a company that provides you with access to the internet; this could be from your computer or even your smartphone.

The ISP makes the internet a reality. Suppose you have a brand-new computer with a built-in modem and a router to connect to the network. However, without an ISP subscription, you will not be able to connect to the internet.

#### WHAT YOU NEED FOR A PAN

To create a PAN, you need a minimum of two computing devices, for example a PC and a smartphone. You will also need a communication channel, which can be wired or wireless to transfer information between the different devices. FireWire and USB are examples of a wired PAN; while WPANs generally use Bluetooth, or even infrared technology.

PANs can only transfer information between devices that are close to each other instead of sending it over the internet (WAN). These networks can be used to transfer files, such as music, photos, videos and calendar appointments.

The easiest way is to transfer the data through a PAN. You can use a USB cable to connect the phone to the laptop. Then follow the **prompts** shown on the laptop, access the files from the phone's storage and copy them onto the laptop. The user can now easily access information.

You can also use another way to transfer data. You can sync both the laptop and phone using Bluetooth, and then sending data to the laptop, or vice versa.



#### How data is transferred

Watch this video to see how data can be transferred from the phone to the laptop:

[https://www.youtube.com/watch?v=gjsiD9i8l\\_8](https://www.youtube.com/watch?v=gjsiD9i8l_8)

## WHAT YOU NEED FOR A HAN

HANs can be both wired or wireless networks. In a typical HAN setup, a router is used as the central point of the network. This router allocates IP addresses and provides internet connectivity to all devices on the network. Any device in the household can then connect to the router, by either connecting to its Wi-Fi network, or by connecting to it with an ethernet cable. Once connected, the devices automatically have access to the internet and network resources.



## NETWORK DEVICES

In most cases, a wired or wireless home network requires only the computing devices, modem and router. Obviously, this depends on your requirements; the more complex you want the network to be, the more money you will be spending on the equipment required. In this section, we will discuss the different network equipment required to create a home network.

A **network adapter**, also known as a network interface controller (NIC), is a piece of hardware that can be added to a computer, allowing it to connect to a network. These days, most computers and laptops have a network adapter built into the motherboards, which makes setting up to the internet much easier.

There are three important types of networking equipment that can look very similar from the outside – i.e. the modem, router and switch. These devices can have ports for different types of cables, such as ethernet cables or digital subscriber line (DSL) cables. However, each has their own different function, as shown in the following table:

**Table 10.3:** *The different network equipment*

TYPE	FUNCTION	IMAGE
Modem	The function of a modem is to connect a computer or network to the internet.	
Switch	The function of a switch is to connect many computers on the same, internal network.	
Router	The function of a router is to organise and route data on and between networks. This may include routing data from a home network to the internet (such as a modem) and connecting many computers to the same network (such as a switch).	

Today, home routers cost roughly the same as home switches and modems. Therefore, for most setups, it is easier to simply purchase a router that can serve more than one function. However, for larger businesses, specialised equipment, such as dedicated modems and switches, may be better suited to the job.

## CONNECTING TO THE INTERNET

To connect to the internet, there are software and hardware requirements that must first be fulfilled. This section will look at those requirements and soon you will be able to create your very own home network with internet!

### SOFTWARE REQUIREMENTS

The software you need to connect to the internet is an operating system, a [web browser](#). A web browser, such as Firefox or Google Chrome, is used to display pages that you visit on the internet. Web browsers often come with their own operating systems.

### HARDWARE REQUIREMENTS

Connecting to the internet is quite simple. You will need the following hardware equipment to connect to the internet:

- A computing device, such as a computer or a smartphone
- A communication channel, such as a telephone line and ethernet cable
- A modem or router to connect to the internet

#### Example 10.1

#### How to set up a Wi-Fi network

Setting up a wireless router is quite simple. If you have purchased your router from an ISP, you will probably have an internet plan with them, and your router will come with all the things you need to connect to the internet, as well as a [subscriber identity module \(SIM\)](#) card.



Figure 10.4: Home Wi-Fi network

... continued



### Something to know

Do not worry if you want to connect a computer that does not have built-in Wi-Fi connectivity. You can purchase a Wi-Fi adapter that plugs into your computer's USB port.

### Example 10.1

### How to set up a Wi-Fi network

... continued

1. Insert the SIM card into the SIM slot of the Wi-Fi router.
2. Connect the router to the power supply. With some routers you might have to screw the two external antennae to the router.
3. Take note of the information that is on the label at the back of the router.
4. Plug the LAN cable into a port of the router and the other end of the cable into the LAN port of your computer.
5. Switch on the router by pressing the *Power* button.
6. Switch on your computer.
7. The power light will be on and will turn a specific colour. This means you are ready to install the software.
8. Follow the prompts on your computer.
9. The Wi-Fi light will be a specific colour to show that the Wi-Fi is enabled.
10. The strength bar on the router will show how strong the signal is.

After you have set up your Wi-Fi network and configured your router, you are ready to connect to the Wi-Fi. This procedure may differ, depending on the router and computing device.

To connect to the Wi-Fi network, you can do the following:

1. Click on your computer's network settings and search for nearby Wi-Fi networks.
2. Choose your network and enter the password you just created.
3. If the connection is successful, open your web browser and type in *www.google.com*. If the page loads, your Wi-Fi connection is working properly.



### Creating a WAN

Create a real-life video of creating a WAN. It can be made step by step, with lots of jump cuts:

1. Get a Wi-Fi router.
2. Plug in the Wi-Fi router.
3. Get the Wi-Fi router name and password.
4. Connect the notebook using the name and password.
5. Open the Wi-Fi router *Settings* page.
6. Set a new Wi-Fi router name and password.
7. Connect to the new Wi-Fi router.

You can use the following link as a guideline: <https://i.imgur.com/SqmxizL.gifv>.



### Activity 10.1

The Jackson family is made up of four people. The two children, Tristan and Jess, stay upstairs, and the parents have a small work-from-home office. The children always have to go downstairs to print documents, or even just use the internet. A friend recommended they set up a network.

1. Differentiate between a PAN and HAN.
2. Briefly explain what a network adapter is.
3. What type of network is best for this situation so that everyone has access to the internet?
4. What three hardware devices are required for this connection?
5. What is a router? Explain its function.
6. Answer the following questions regarding the scenario:
  - a. What type of network is best suited in this context? Motivate your answer.
  - b. Explain two advantages and disadvantages of the answer you gave in (a).

## REVISION ACTIVITY

1. Explain the difference between a HAN and a PAN. (4)
2. List one advantage and one disadvantage of a HAN. (2)
3. List one advantage and one disadvantage of a PAN. (2)
4. Three common network devices are modems, switches and routers. Match the description of the device to its name. Write down only the name of the device:
  - a. Used to connect computers or networks to the internet (1)
  - b. Use to organise and route data on and between networks (1)
  - c. Used to connect many computers on the same network (1)
5. Write down the letter that matches the correct or best answer. Which of the following devices is most likely to have a built-in network adaptor?
  - A. Microwave (1)
  - B. Refrigerator (1)
  - C. Telephone (1)
  - D. Sewing machine (1)
6. What communication medium is most likely to be used in a PAN? (1)
7. Sifiso has a desktop computer with the Windows 10 operating system installed on it. He has installed on it the Google Chrome browser on his computer. He wishes to connect his computer to the internet. He already has a 24-month contract with Telkom.
  - a. Does Sifiso have the correct software to connect to the internet? (1)
  - b. What additional hardware device, other than his computer, will Sifiso need to connect to the internet? (1)

**TOTAL: [15]**

## AT THE END OF THE CHAPTER

Use the checklist to make sure that you worked through the following and that you understand it.

NO.	DID YOU ...	YES	NO
1.	Understand the difference between the different networks.		
2.	Learn what the wired and wireless networks are.		
3.	Understand the advantages and disadvantages of PAN.		
4.	Identify the computing devices required for a PAN.		
5.	Learn how to connect to the internet.		

# THE INTERNET AND WORLD WIDE WEB

## CHAPTER OVERVIEW

Unit 11.1 The internet

Unit 11.2 The Web

Unit 11.3 Search engines

Unit 11.4 Downloads and uploads

At the end of this chapter, you should be able to:

- Explain what the internet and world wide web (WWW) are.
- Understand the concepts used in the Web.
- Differentiate between a website and web page.
- Understand what a web address is and the different elements that it consists of.
- Identify the different types of websites.
- Use the web browser.
- Open, close and switch between tabs.
- Use a search engine to browse the internet.
- Understand what uploading and downloading are.

## INTRODUCTION

The internet has become increasingly important in everyday life for people all over the world. It is the biggest network made up of billions of computers and other computing devices, such as smartphones, tablets, laptops, etc. The internet allows us to communicate with anyone across the world and access almost any type of information we need.

The biggest trend now, thanks to the internet, is social media. So, before you post anything new on Instagram, let's learn more about the internet and social media.

Social media and other interactive, crowd-based **communication platforms** reached new heights at the beginning of the 21st century. This has resulted in people being more up to date both in terms of their own lives and in the lives of others.

In this chapter, we will look at what the internet and world wide web (WWW) are, the different types of websites, as well as browsers and how to do some basic browsing.

## 11.1 The internet

The internet is a world-wide system of computer networks that are connected to each other. These networks connect with each other using cables, telephone lines and communication satellites.

When a computer is connected to the internet, it allows a person to access emails, music videos, pictures and any other relevant information. If a person is connected to the internet, this person is said to be working **online**.

### INTERNET ADDRESS

Have you ever wondered about the fact that if there are 250 billion emails sent every day from our smartphones, PCs or laptops, how exactly do they go to the correct place? The answer is that every device connected to the internet receives a unique IP address. Whenever a message is sent over the internet, it is sent to a device's IP address. An IP address consists of four sets of numbers, which are separated by dots, as shown below:

#### My IP Address Is:

IPv4: **197.98.0.86**

IPv6: Not detected

**My IP Information:**

---

ISP: Internet Solutions  
 City: Johannesburg  
 Region: Gauteng  
 Country: South Africa

↑ **Hide My IP Address** ↓  
Click Here

Click for more details  
 about 197.98.0.86



Leaflet | © OpenStreetMap Terms

Location not accurate? [Update your IP location](#)

Show Me More About My IP

**Figure 11.1:** An example of a South African IP address



#### WHAT IS THE INTERNET?

Watch the following interesting video to listen to what the co-inventor of the internet says:

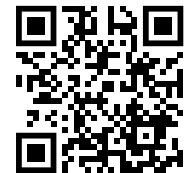

<https://www.youtube.com/watch?v=Dxcc6ycZ73M>



### Guided Activity 11.1

1. To see what the IP address is of the computer you are currently working on, do the following:
  - a. Open a web browser. Ask your teacher to show you how to do it if you do not know.
  - b. Go to the Google search engine.
  - c. Type in “What’s my IP?” in the search box.  
Your IP address will be displayed at the top of the search results.

As South Africa only has **dynamic IP addresses**, the IP address will change every time you connect to the internet.

## 11.2 The world wide web

The world wide web (WWW) is a part of the internet where documents and other resources can be accessed. The WWW is often called “The Web”.

The internet and the WWW are often confused. The internet is, in fact, the biggest network in the world; while the WWW is a collection of documents and other resources that you can browse, or access, through the internet.

Most resources are **websites** that can consist of text, pictures, audio clips, video clips, animations, etc. After connecting to the internet, you can browse websites using a type of application called a **web browser**.

You will learn how to browse the internet, as well as how to navigate to the different websites using **uniform resource locators (URLs)** and tabbed browsing.

### IMPORTANT CONCEPTS USED WITH THE WORLD WIDE WEB

There are some important concepts that you should learn in order to understand the Web better. Some of these concepts will be explained in more detail in the sections to follow.

A **web server** is a computer that hosts a website, for example if you want to access [www.wikipedia.org](http://www.wikipedia.org), the web server receives this request and uses **hypertext transfer protocol (HTTP)** to format and then present the website to you.

A website is a collection of web pages, for example Wikipedia is a website that has billions of web pages about different topics and articles. A web page is a single page of **hypertext mark-up language (HTML)** text, which can display text, media, images, or interactive material, such as audio files.

HTML is a type of coding language used on web pages to display text, images and audiovisuals. Documents on the internet that are not **encoded** in HTML are not web pages.

### USING A WEB BROWSER

A web browser is a type of software that lets you browse websites or web pages. Every time you Google something, you are using a web browser to read what is on the web page. There are different types of web browsers, for example Google, Mozilla Firefox and Internet Explorer.

In Chapter 5, we looked at the basics of connecting to the internet. Remember, you need to have a working internet connection to test out all of these things!



#### Something to know

People get confused between a web server and a website, for example, if someone is saying “my website is not loading”, they actually mean that the web server is not responding, which then results in the website not loading.



#### HTML BASICS

Just to pique your interest, you can read a bit more about HTML basics by clicking on this QR code:



[https://developer.mozilla.org/en-US/docs/Learn/Getting\\_started\\_with\\_the\\_web/HTML\\_basics](https://developer.mozilla.org/en-US/docs/Learn/Getting_started_with_the_web/HTML_basics)



## BROWSER BASICS

Have a look at this video to understand the basics of the web browser:



[https://www.youtube.com/watch?time\\_continue=195&v=FxirRVJWUTs](https://www.youtube.com/watch?time_continue=195&v=FxirRVJWUTs)

For the purpose of this book, we will use the Google Chrome browser. However, you can use whichever browser you want to. Browsers may have a different look or feel, but they all work pretty much in the same way.

To open a web browser, click on the *Start* menu and enter the name of one of the web browsers. You can then click on the icon to open the browser.

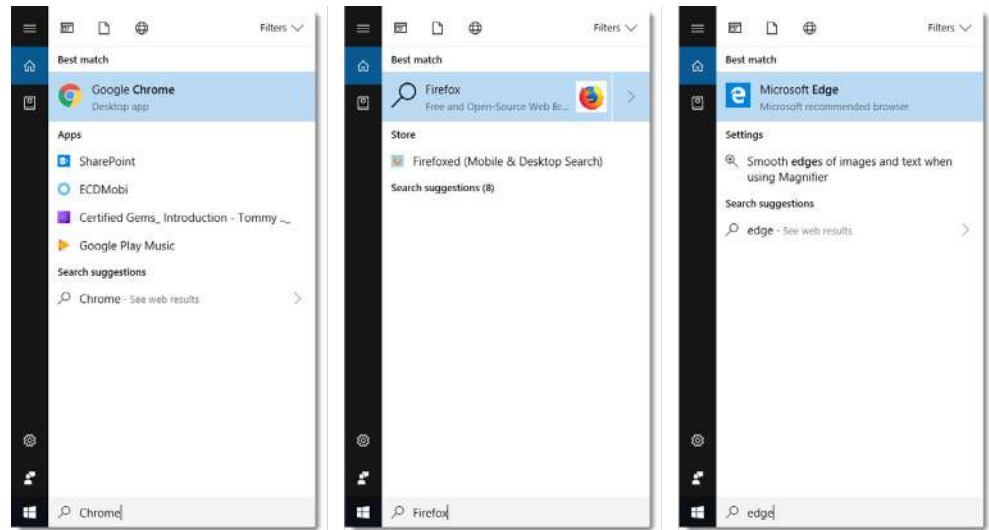

**Figure 11.2:** Opening the web browser

You will learn more about how to use the browser later in this chapter.

To browse to a website, you must know its unique web address, such as [www.instagram.com](http://www.instagram.com) for the Instagram website. Once you know the address, you can enter it into the address bar at the top of the browser.



### Guided Activity 11.2

Do the following activity in the class under the guidance of your teacher.

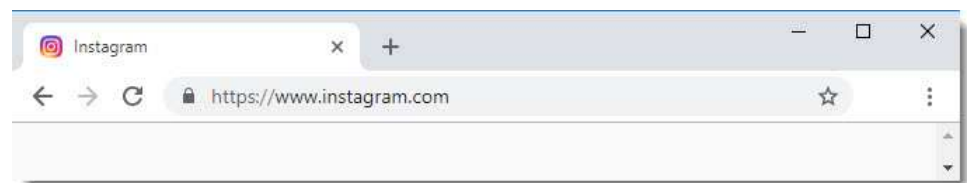

**Figure 11.3:** Entering the web address

As soon as you press *Enter*, the web page should begin to load.

... continued

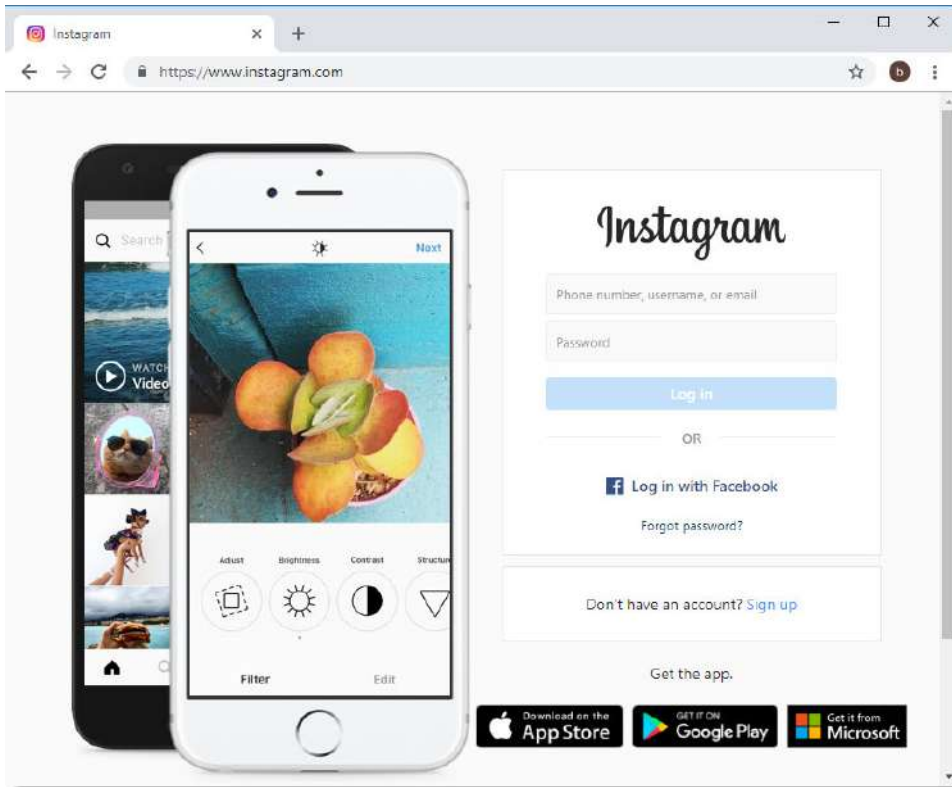

Figure 11.4: The Instagram web page

You can now browse the website by clicking on buttons and links, or following the instructions on the page.

## WHAT IS THE DIFFERENCE BETWEEN A WEB PAGE AND A WEBSITE?

A web page refers to the text, images, or graphics displayed in a web browser. A web page is generally a single page of content on a website. You can access a web page by entering the URL into the address bar of a web browser.

A website is a collection of web pages that are usually linked by **hyperlinks**. For example, if you go to the *Sunday Times* website, it consists of many web pages. On each page, you will find various articles, columns and content that have been grouped into different categories.

To help you understand the difference between web pages and websites better, look at the example on the following page.

### Something to know

If you are still a little bit confused about websites, think of it as a book with many pages.

### Different types of websites

Make a screen capture video with text and voice-overs, explaining the different types of websites. For each type of website, you can quickly explain what the purpose of that type of website is, and then show an example that meets that purpose.

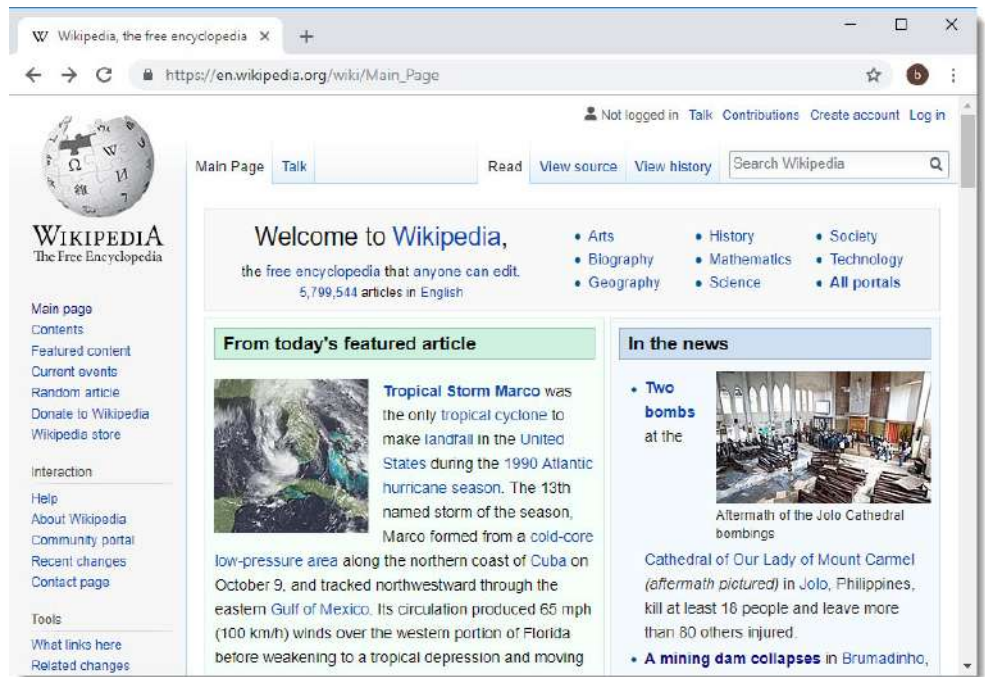

**Figure 11.5:** Wikipedia is an example of a website that has millions of web pages

There are many websites on the WWW; from how to remove a carpet stain, to the latest news on what is happening in the world. However, for the purpose of this book, we will focus on the following types of websites and their purpose.

**Table 11.1:** Types of websites

TYPE	PURPOSE	EXAMPLES
Blog, weblog or vlog	A website that posts short, informal stories about any topic. It is a good place to find information about a topic, place, or a hobby. This is usually run by an individual or a group of people.  A vlog is a video blog or video log. It is a blog where all, or most of the content is in video format.	<ul style="list-style-type: none"> <li>• <a href="http://www.cakewrecks.com/">http://www.cakewrecks.com/</a></li> <li>• <a href="https://boingboing.net/">https://boingboing.net/</a></li> <li>• <a href="https://mentalfloss.com/">https://mentalfloss.com/</a></li> <li>• <a href="https://catoverberg.wordpress.com/">https://catoverberg.wordpress.com/</a></li> </ul> Many examples of vlogs can be found on YouTube.
Social network	A website that connects you to people by making friends, seeing what they are up to, and posting your thoughts and photos.	<ul style="list-style-type: none"> <li>• <a href="https://www.facebook.com/">https://www.facebook.com/</a></li> <li>• <a href="https://twitter.com/">https://twitter.com/</a></li> </ul>
Web application	An application that runs directly on a website, such as a word-processing application, or a fitness tracker.	<ul style="list-style-type: none"> <li>• <a href="https://docs.google.com/">https://docs.google.com/</a></li> <li>• <a href="https://www.fitocracy.com/">https://www.fitocracy.com/</a></li> </ul>
Wiki	A website where people from across the world can edit or modify the information on a website. The most famous is <i>Wikipedia</i> , the online encyclopaedia. It also provides links to the original sources so that you can check whether the information is correct or not.	<ul style="list-style-type: none"> <li>• <a href="https://en.wikipedia.org/">https://en.wikipedia.org/</a></li> <li>• <a href="https://tvtropes.org/">https://tvtropes.org/</a></li> </ul>

## URLS, URL SHORTENER AND THE ADDRESS BAR

Each web page on the internet has its very own unique address called a URL, which tells the internet exactly what page you want to see on a website. Think of a URL as a street address that tells the web browser where to go on the internet.

When you type a URL into the address bar of the web browser and press *Enter*, the browser will take you to that specific page. For example, in the figure below, we typed *www.bbc.com* in the address bar (highlighted in green), which will then load the BBC web page.

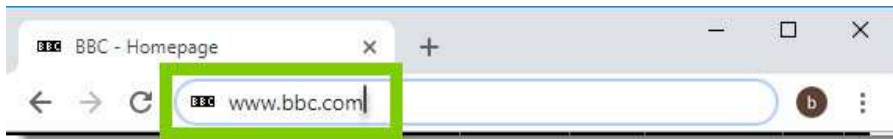

**Figure 11.6:** *Typing in a URL in the address bar*

In the following example, you will learn more about URLs. Each segment in a URL is a part that makes up the web address.

The **domain name** is the most important part of an internet address. This could be a word or a phrase that an internet site has identified as the name of the website. People use it to find information on the internet, for example businesses use it to get people to visit their websites.

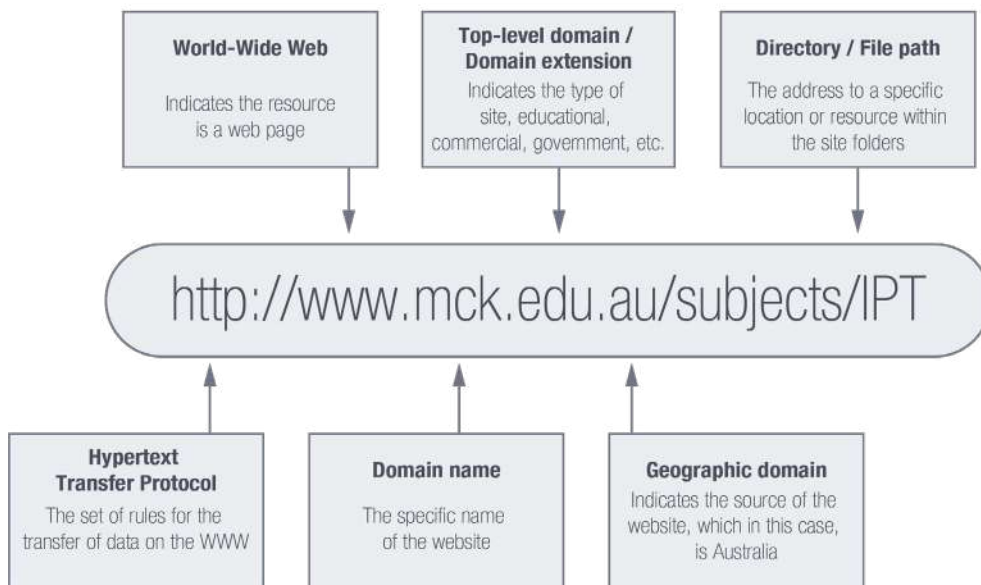

**Figure 11.7:** *The different parts of a URL*

The tables on the following page show the different codes you could come across indicating an organisation type and the country of origin.

## URL SHORTENERS

A URL shortener is an online application that converts a normal URL into a much shorter format. The user has to copy the website address into the URL shortener application and the tool will convert the address to a much shorter one.



### UNDERSTANDING URLS

Watch this video to understand the different parts of the URL:



[https://www.youtube.com/watch?time\\_continue=14&v=5Jr\\_Za5yQM](https://www.youtube.com/watch?time_continue=14&v=5Jr_Za5yQM)



### Guided Activity 11.3

Do the following activity in the class under the guidance of your teacher.

1. Open the website: <https://bit.do/>.
2. Copy then paste the following address to shorten it: <https://www.blog.google/products/maps/wheres-waldo-find-him-google-maps/>
3. Click on “Shorten”.
4. What were the results?  
Something like this – <http://bit.do/eCuFC>?

Each time you do this, a different URL is generated.

**Table 11.2:** Codes showing the different types of organisations

CODE	TYPE OF ORGANISATION
.com	Commercial
.co	Registered company
.ac	Academic institutions
.org	Organisation
.net	Network providers
.edu	Education

**Table 11.3:** Examples of country codes found in URLs

CODE	COUNTRY
.au	Australia
.ca	Canada
.uk	United Kingdom
.us	United States of America
.de	Germany
.za	South Africa

## LINKS

When you see a word or phrase on a web page that is blue or underlined in [blue](#), it is usually a hyperlink or link in short. Links are used to navigate the Web. When you click on a link, it will take you to a different web page. Also, sometimes when clicking on a link, the mouse cursor will change to a hand icon before you open the link.

In this example, we have opened a Wikipedia web page and have clicked on the Gauteng link to learn more about it.



Figure 11.8: Clicking on the link

Clicking on the Gauteng link will take you to the following web page:

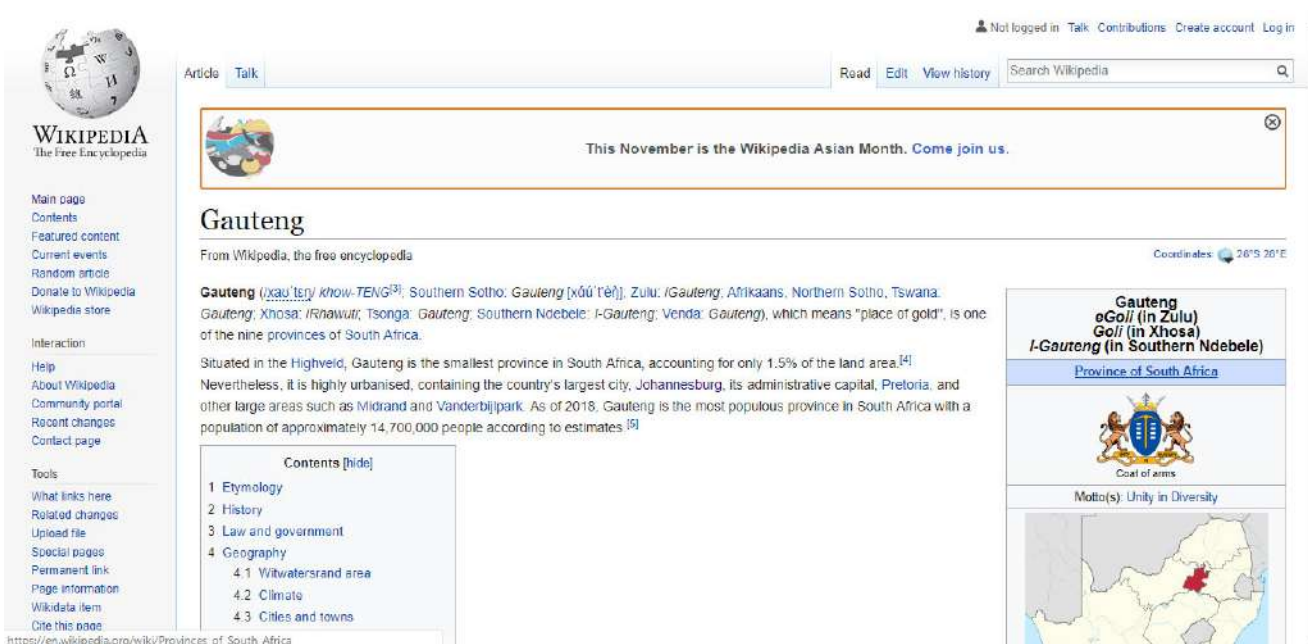

Figure 11.9: The opened web page

Each of the blue-coloured words in the text are hyperlinks to other web pages.



## Guided Activity 11.4

Do the following activity in the class under the guidance of your teacher.

Many websites use images as links. After clicking on the image, it will take you to a new page. In the example below, if we click on the image, it will open a page with more information about it.



**Figure 11.10:** An image link

Take note that links do not always go to other websites. Links can also allow you to download a file, such as a music file, software file and so on. When you click on a link like this, it will download the file to your device. In the example below, an installation file for a new application can be downloaded.



**Figure 11.11:** Link to download a file

As you have learned, links do not all look the same. Links can have the following different forms:

- Text that is **blue** and **underlined**
- Images, such as photos
- Tabs on a web page
- Text that is not underlined, but **bolded** and appears in another colour

Links play a very important role when using the Web. It allows you to access different web pages, navigate between these pages and download files.

## NAVIGATION BUTTONS

**Navigation buttons** are found on the web browser and allow you to do many things. The arrow buttons, which are called the *back* and *forward* buttons, let you go to the websites that you have recently visited. If you click and hold on one of the buttons, you can view the recent browsing history.

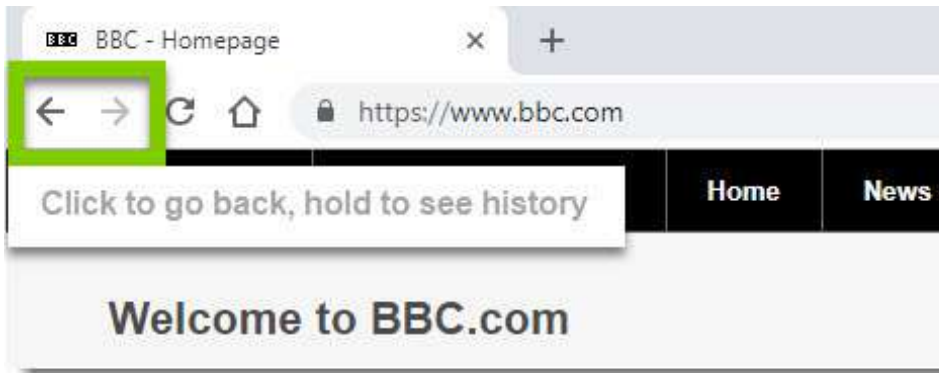

**Figure 11.12:** *Back and forward buttons*

The *Refresh* button will reload the current web page that you are on. If a website stops working, you can just click on the *Refresh* button.

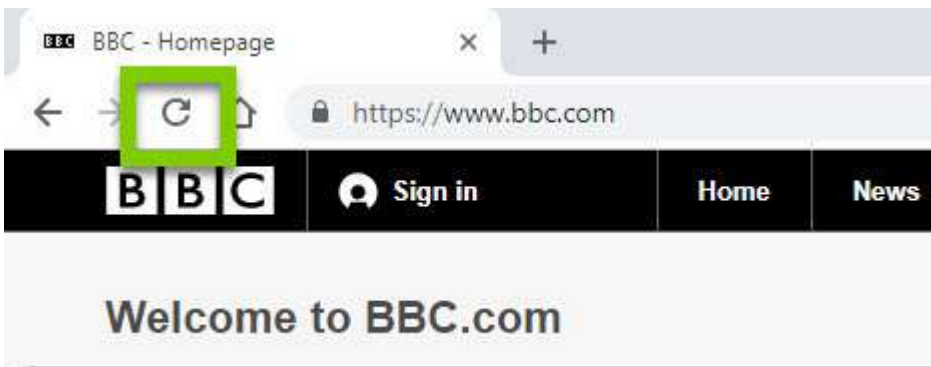

**Figure 11.13:** *Refresh button*

## TABBED BROWSING

Many web browsers let you open links in a new tab, which is great because you can open as many links as you need and they will all stay in the same browser window. This prevents separate browser windows from being open on the computer screen.



## Guided Activity 11.5

Do the following activity in the class under the guidance of your teacher.

To open a new tab, you can do the following:

1. Right click on the link and select *Open link in new tab*. Keep in mind that the wording might differ from browser to browser.



2. To switch tabs, click on any tab that is not selected.



3. The web page will then open.



4. To close a tab, click on the X.

... continued



5. To create a new blank tab, click on the button found on the right of the open tabs.



## ADVANTAGES OF TABBED BROWSING

Some of the advantages of using tabbed browsing, include the following:

- Allows the user to view many web pages at once.
- If users come across a link in the web page they are currently viewing, they can click on the link and a new web page will open in another tab without closing the current web page.
- Allows the user to move between web pages without actually closing any web pages.



### Take note

You can use the following useful hotkeys when browsing. Open the web browser and try doing the following using the keyboard:

- **Open a tab:** *Ctrl+T*
- **Switch between tabs:** *Ctrl+Tab*
- **Close a tab:** *Ctrl+W*



### Activity 11.1

1. Briefly explain the difference between a website and a web page.
2. Complete the crossword puzzle below by answering the questions that follow:

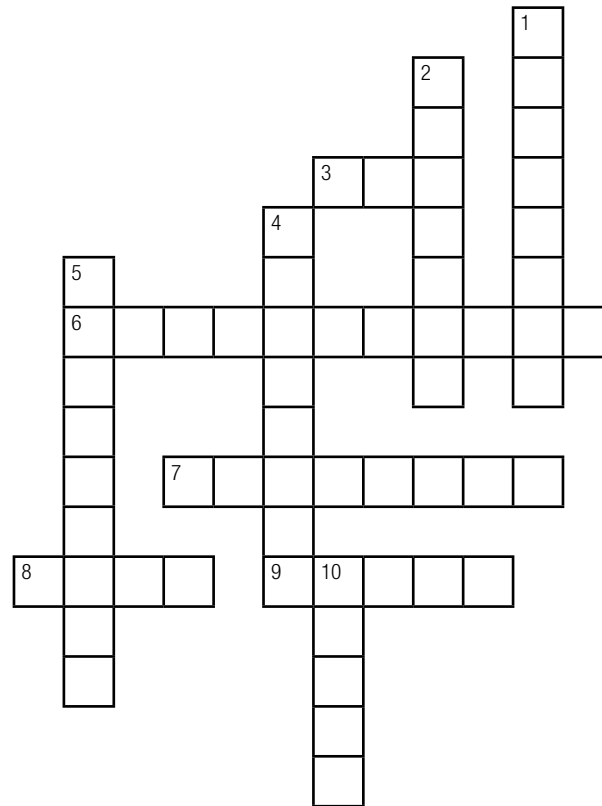

Down:

1. A social network website
2. A page made up of text, pictures, audio clips, video clips and animations
4. A website about a single person
5. An example of a news website
10. Brings several types of websites together

Across:

3. When you open a link, it opens in a new \_\_\_\_\_
6. A website you can check load-shedding schedules
7. A website that posts short and informal stories
8. A website that collaborators can edit and modify
9. An example of an educational website

## 11.3 Search engines

In the world we live in today, more and more things are being done online. You need basic computer skills to do research, be social and do many other things on the internet. The ability to search for information on the internet is an important skill to have and by improving this skill, you can find what you are searching for without going through many irrelevant websites.

Since there are billions of websites on the Web, there is a lot of information available. Search engines make access to this information much easier. We will look at the basics of using a search engine and some basic techniques on how to get more useful search results.

### SEARCHING FOR INFORMATION

Browsing to the correct website usually only works well when you know the address of the website, or if you need to visit a specific website. However, it is not practical to keep a list of web addresses on you all the time. You might be looking for something specific on the internet, shopping for something new but need to compare prices, or you might just be looking for new interesting websites. For that, you need a **search engine** to find the information you are looking for.

Three popular search engines are:

1. Google ([www.google.com](http://www.google.com))
2. Microsoft Bing ([www.bing.com](http://www.bing.com))
3. Yahoo ([www.yahoo.com](http://www.yahoo.com))

Of the three search engines, Google is the most powerful and easy-to-use search engine.

### BASIC BROWSING AND SEARCHING TECHNIQUES

In the following activity, we will search for “grey matter”.



#### Guided Activity 11.6

Do the following activity in the class under the guidance of your teacher.

To search for something on the internet, you can do the following:

1. Open the web browser and navigate to a search engine. Most web browsers generally allow you to search directly from the address bar. However, some browsers might actually have a separate search bar next to the address bar.
2. Type in one or more keywords (this is also known as the *search term*).
3. Press *Enter* on the keyboard.
4. After you have pressed *Enter*, you will see a list of all the relevant websites that match the search words. If a site looks interesting or looks like what you are looking for, click on the link to open it.

... continued

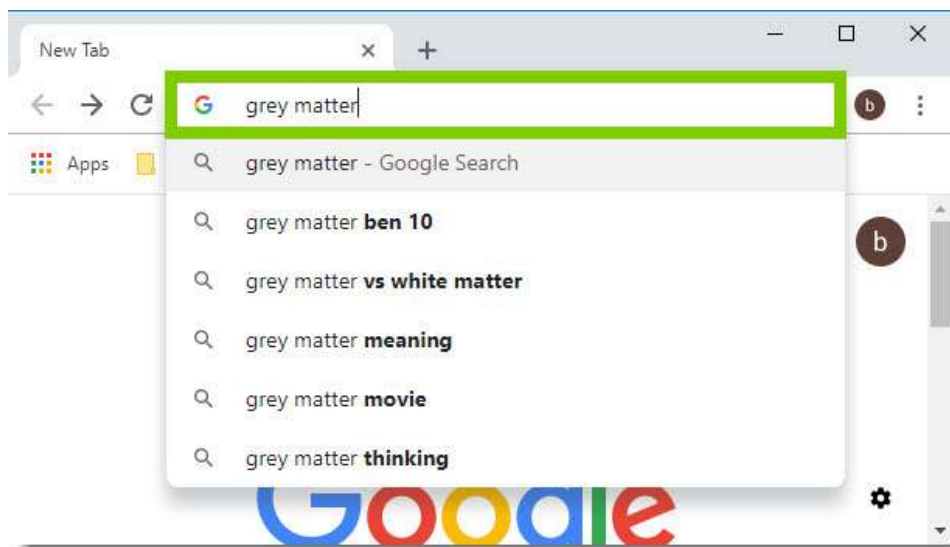

### 5. Skim through it.

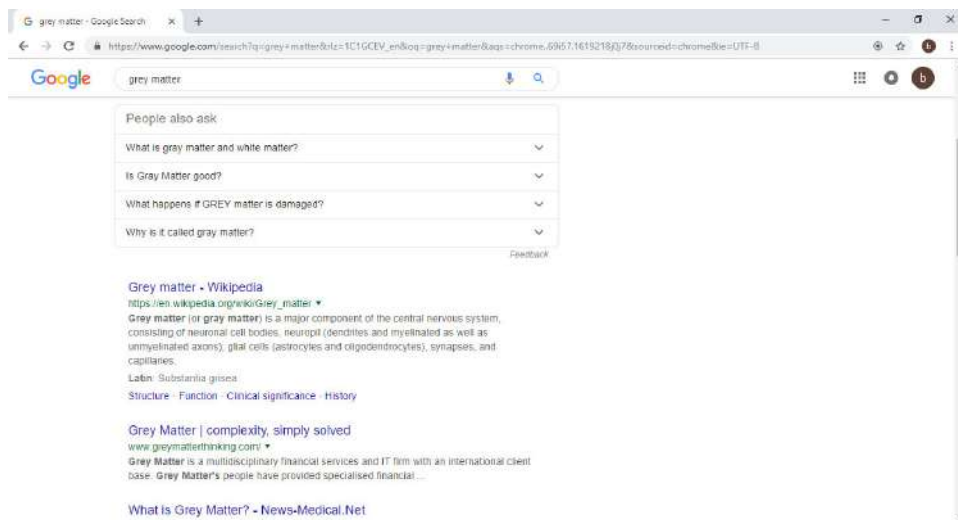

### 6. If it is not exactly what you are looking for, return to the results and look at other websites.



#### BASIC SEARCH STRATEGIES

Have a look at this video to get a better idea of search strategies:



<https://www.youtube.com/watch?v=7RIB1CJovTs>

## REFINING YOUR SEARCH

If you still have problems finding the exact website, you can use the following special characters to help refine your search:

- To exclude a word from the search, type in a hyphen (-) at the beginning of the word. For example, if you want to find grey matter results without mention of the movie with the same name, you could search for *grey matter - movie*.
- At the same time, if you use a (+) before the beginning of the word or phrase, the search results will show results with just the movie mentioned e.g. *grey matter + movie*.
- You can also search for the exact words or phrases, which can give you much better results. To do this, use quotation marks (" ") before and after the search words. For example, if you search for "grey matter songs", the search results will only have songs about grey matter.

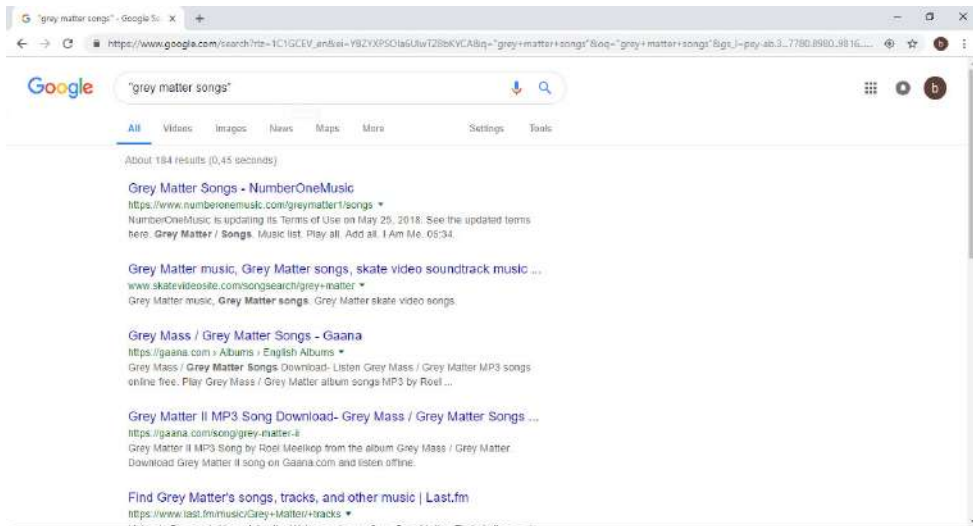

**Figure 11.14:** A refined search

The best results are usually shown on the top page, with the least popular or visited results appearing on the second and third search pages. Since the first search results are usually the best, if you do not find what you are looking for on the first page or two of the results, you should try a different search phrase, or try to use an advanced search technique.

## SEARCH TECHNIQUES

The following table highlights a few of the most useful search techniques.

**Table 11.4:** Search techniques

PURPOSE	METHOD	EXAMPLE
Search for a specific type of web page	Once you have opened Google Search, click on the <i>Images</i> , <i>News</i> , <i>Videos</i> or <i>Maps</i> button to search for those items.	Search: <i>Meghan Markle</i> Click on <i>News</i> and then type in <i>Meghan Markle</i> .
Search for web pages updated at a specific time	Once you have opened Google Search, click on the <i>Tools</i> button. Click on <i>Any time</i> and then select the time period for which you are looking.	Search: <i>Meghan Markle</i> <ul style="list-style-type: none"> <li>● Click on <i>News</i></li> <li>● Click on <i>Tools</i></li> <li>● Click on <i>Any time</i></li> <li>● Select <i>Past week</i></li> </ul>
Search for results from a specific website	Add the phrase <i>Site:</i> followed by the website to the search query.	Search: "violin music" site: youtube.com
Search on social media	Add the name of the social media website after the @ symbol in the search query.	Search: "violin" @twitter

These techniques can be very useful. However, because search engines have become extremely efficient, you can even find information without using these "special" techniques.



### Guided Activity 11.7

Using the information that you just learned, do the following activity during class. Your teacher will guide you through this activity.

1. Open a web browser.
2. Go to the Wikipedia website by typing in its URL: <https://www.wikipedia.org/>.
3. Click on the *English* tag.
4. Search for *Bafana Bafana*.
5. Click on the hyperlink *Nickname*. What does the double use of the name Bafana Bafana mean?
6. Open a new tab.
7. Type in *South African rugby*.
8. Click on *News*
9. Click on *Rugby: South African schools with the most Springboks*. According to this news article, which school has the most Springboks? How many does it have?
10. Right click on the tag *Golden Lions* at the bottom of the page.
11. Click *Open link in new tab*. What does the heading say about the Super Rugby final?
12. Open a new tab.
13. Search for *Sunspots without the inclusion of climate*.
14. To what do the search results you found on the first page refer?
15. Search for *Sunspots with the inclusion of climate*.
16. What do you find in the search results? List the names of the first three websites.
17. Do you see any reference to sunspots on the skin? Why or why not?
18. Close all the websites by clicking on the X of each tag.

## 11.4 Downloads and uploads

By now, you might have come across the terms downloading and **uploading**. Downloading is when the computer or smart device receives a file or data from the internet. Uploading, on the other hand, is when the computer or smart device sends a file or data to somewhere on the internet.

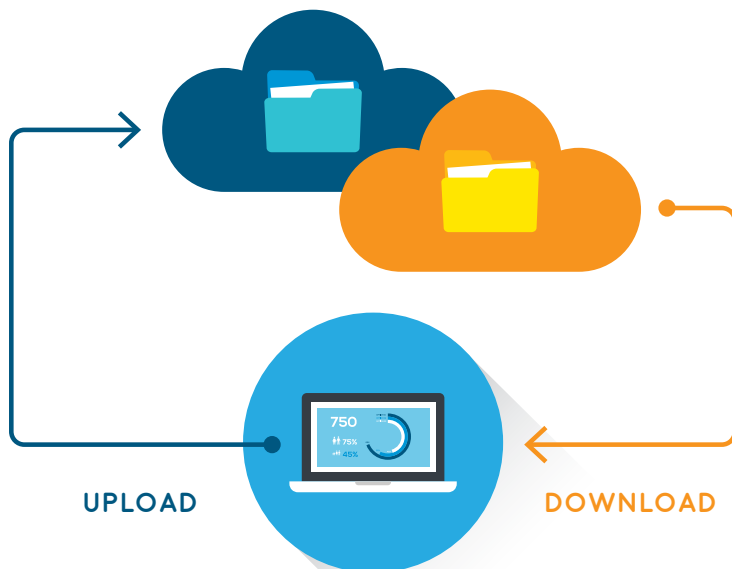

**Figure 11.15:** *Uploading and downloading with a PC*

You have probably, at some point, downloaded or uploaded a file or data from the internet. Do you remember downloading a music file or posting (uploading) a photo on your Facebook wall or Instagram?

### DOWNLOADING

To be able to download something from the internet, it is an important skill to learn as you will use it throughout your lifetime to download software programs, music, photos, documents, videos, etc.

To take you through a download process, you can look at the following example of downloading a video-player software program.



#### Guided Activity 11.8

Do the following activity in the class under the guidance of your teacher.

To download VLC, you can do the following:

1. Use the web browser to go to the website for VLC: <http://www.videolan.org/>.
2. Once the website has loaded, find and click on the *Download VLC* button. This will download the approximately 40 Mb-VLC installer onto the computer.

... continued



## Guided Activity 11.8

... continued

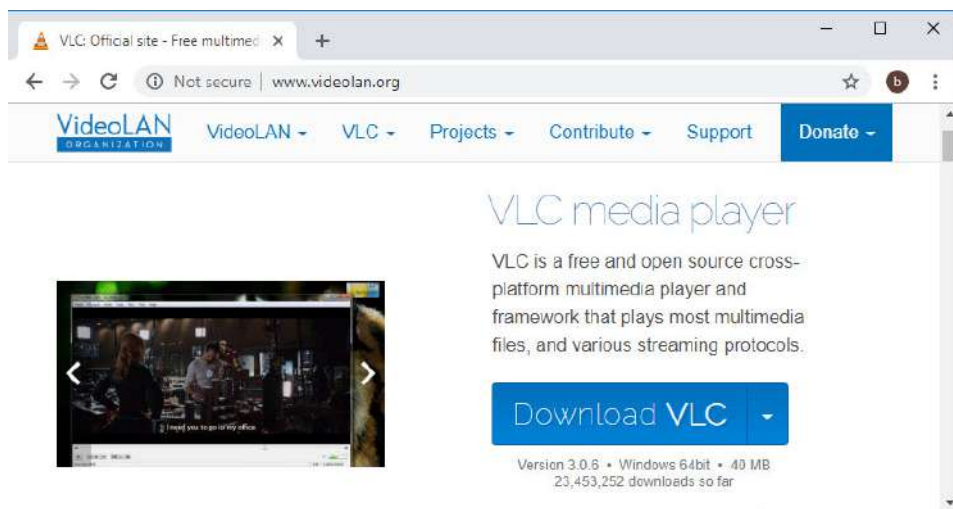

- When the download has completed, the file will be saved on the computer, or it will open with the program that you selected.
- If you have a problem finding the download, you can always do the following: Click on the three vertical dots found on the top right-hand side of the screen and choose *Downloads* from the drop-down menu. You will be able to see all the files that you downloaded and from that, you can choose the file you need.

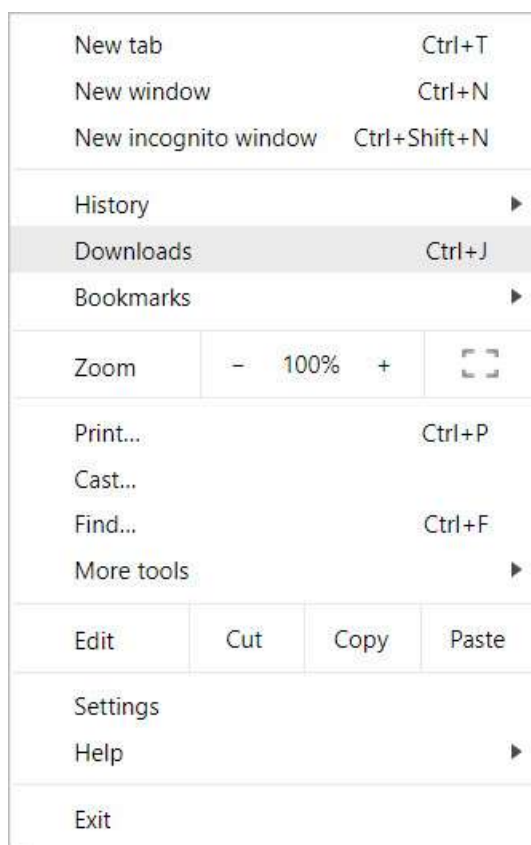

### Something to know

Some browsers or even files do not have the “automatic” download process when you click the link to the file. In such a case, you will have to right click the link and choose the *Save link as* option, and then choose a location to which you can download the file.



## Guided Activity 11.9

Do the following activity in the class under the guidance of your teacher.

1. Open the web browser.
2. Go to Google web page.
3. Google the following: Types of input devices "doc".
4. From the search results, browse for the website that best describes input devices.
5. Click on the website name.
6. Follow the instructions to download the document.
7. Open the document in Word.
8. Save the document as a PDF and call it: *Uploadeddoc*.

## UPLOADING

You can use the upload function to send emails, post photos on a social media site, upload files to Google Drive, etc.

If a site enables uploads, it will have an upload option to help perform the upload or file transfer. Every site has a different uploading process. A dialogue box opens after you click on the *Upload* button. For example, Facebook has an icon that is an image. This is Facebook's *Upload* button for an image, starting the upload process. You can upload an image or file to a website that allows it.

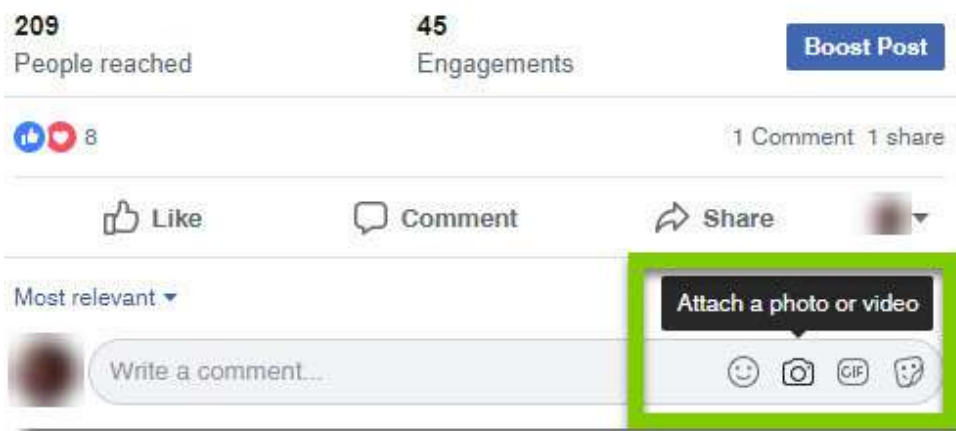

**Figure 11.16:** Upload button on Facebook

After clicking on this button, the dialogue box will appear, prompting you to select a file. Navigate to the location to where the file is stored and click on the *Open* button. A progress bar will track the upload process.

Some websites have a drag-and-drop interface. For example, when logged into Google Drive, you can upload files or even zipped folders from the computer to the browser window by dragging and dropping the file.

Let's look at the following example of *Ted Talks*, an organisation that uploads videos from expert speakers about a variety of topics, such as education and business.



### Guided Activity 11.10

Do the following activity in the class under the guidance of your teacher.

To upload a video on a website e.g. *Ted Talks*, you can do the following:

1. First of all, the user needs to log into the TED Media Uploader. If this is your first time, you can request the uploader [here](#).
2. Once you have logged in, select the event category of the video that the user wants to upload.
3. Click on “Upload Video” to upload a new video.
4. Follow the instructions, for example the type of file you are loading, as well as other personal details.
5. Include a video description.
6. Click “Upload”.



### Activity 11.2

1. Which one of the following is NOT a good technique used to refine an Internet/web search?
  - A. Using one word only
  - B. Specifying the domain
  - C. Using quotation marks
  - D. Using operators such as “and” and “not”
2. Define the following terms:
  - a. Search engine
  - b. Web application
3. Complete the table below by indicating in Column B whether the action in Column A is downloading or uploading. Only write the number and the answer down.

COLUMN A	COLUMN B
Putting photos up on a Facebook wall	3.1
Using a torrent to legally download movies	3.2
Getting music from beemusicplayer	3.3
Getting a PDF document from the internet	3.4

### REVISION ACTIVITY

1. Write down the letter that matches the correct answer:  
The letters “http” stand for:
  - A. Hypertype transport protocol
  - B. Hypertext transfer protocol
  - C. Hypertext transfer process
  - D. Hypertype transfer protocol(1)
2. Which of the following web browsers is installed with Windows 10?
  - A. Google Chrome
  - B. Mozilla Firefox
  - C. Edge
  - D. Safari(1)
3. Your friend thinks that the internet and the WWW are the same thing. Explain to her what the difference is between them.
 (4)

... continued

REVISION ACTIVITY

... continued

4. Study the screenshot below that shows the home page of a website and use it to answer the questions that follow:

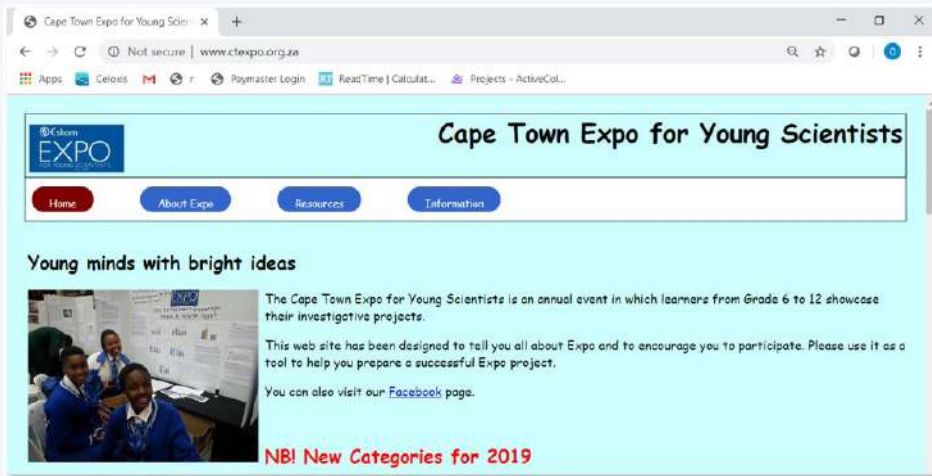

- a. What is the URL of the web page? (1)
  - b. What is the domain name of this web page? (1)
  - c. What is the geographical domain of this web page? Which country is this? (2)
  - d. Name two other web pages that are part of this website. (2)
  - e. Why is the word "Facebook" in blue and underlined? (1)
5. For each of the scenarios below, write down the type of website. Choose your answer from blog, weblog, social network, wiki or web application.
- a. Zanele has a website where she keeps a journal of the exotic foods she enjoys (1)
  - b. Rebogile has created a website that people can use to create a monthly budget and to track their expenses (1)
  - c. Julia, a Life Sciences teacher, has a website where her learners can go to find study tips, as well as answers to recent examination questions (1)
6. The screenshot below shows part of the Google Chrome browser. Use it to answer the questions that follow:



- a. The Google Chrome browser uses tabbed browsing. Mention two advantages of using tabbed browsing. (2)
- b. Which tab is currently active? Explain how you arrived at your answer. (2)
- c. What is the function of the + button after the second tab? (1)
- d. What is the meaning of the closed padlock in front of the URL in the address bar? (1)
- e. Give the name of another browser other than Google Chrome. (1)

... continued

## REVISION ACTIVITY

... continued

7. Francois wants to take some friends that are visiting from Europe to the top of Table Mountain in Cape Town. He plans to use the cableway to travel to the top of the mountain. Francois uses the Google search engine and types in "Cape Town" in the search box. He gets about 650 000 000 results.
  - a. How could Francois change his search phrase to only get results for the Table Mountain cableway? (2)
  - b. Name another search engine that Francois could use, other than Google. (1)
8. Explain the difference between downloading and uploading when using the internet. Give an example of each. (4)

**TOTAL: [30]**

## AT THE END OF THE CHAPTER

Use the checklist to make sure that you worked through the following and that you understand it.

NO.	DID YOU ...	YES	NO
1.	Understand the different concepts used with the Web.		
2.	Understand the difference between a web page and a website.		
3.	Learn about the different types of websites and their purpose.		
4.	Identify the different parts of a URL and what they mean.		
5.	Understand what tabbed browsing is and how it is useful.		
6.	Learn the different techniques on how to use search engines.		
7.	Understand the concept of uploading and downloading.		

# INTERNET COMMUNICATION

## CHAPTER OVERVIEW

Unit 12.1 Electronic communication devices

Unit 12.2 Email as a form of e-communication

Unit 12.3 Basic emailing

At the end of this chapter, you should be able to: 

- Describe what electronic communication is.
- Describe the different electronic communication devices.
- Electronically communicate using a PC.
- Discuss the different electronic communications.
- Explain the difference between ISP versus web-based email.
- List and explain the different features of email, such as the “Cc” and “Bcc” fields, attachments, and address books.
- Compose email messages.
- Understand how to send, receive, forward, Reply to and Reply to all using email.
- Apply netiquette rules over email.
- Understand email etiquette.

## INTRODUCTION

In the past, communication between people was done either face to face, using the telephone, or by writing letters. Now, we live in a world where electronic communication or better known as e-communication has taken over. Think about it, when last did you go to a family or friend gathering and no one took their phones out to message a person? This is how much electronic communication has taken over.

Electronic communication refers to any data, information, words, photos, **emojis** and symbols that are sent electronically to one or more people. This can be done through emails, social media, newsgroups, chat rooms, video conferencing, instant messaging, phone and fax. With just one click on the send button, you can say “hi” within seconds to your friend in Spain!



**Figure 12.1:** Examples of e-communication

Up to a few years ago, email was the best way to communicate with people online. However, these days there are many other ways to communicate, allowing you to do things such as:

- Making phone calls using your computer
- Sharing the same message with many people at the same time without sending the same message individually
- Interacting with different platforms on the internet and making comments and statuses, or even sending messages
- Seeing the person on the other side of the world you are talking to through video conferencing

In this chapter, we will look at the different electronic **communication devices** and the different types of applications used in electronic communications. We will also look at email and how to compose and send basic email messages, as well as basic email **netiquette**.



## 12.1 Electronic communication devices

An electronic communication device refers to any type of computerised device (instrument, equipment, or machine) with software that can compose, read, or send any electronic message using radio, optical or other electromagnetic systems. An electronic message can be a text message, email, an instant message such as WhatsApp, teleconferencing, social networking, Skype, blogs, or even access to an internet site. It can consist of signs, signals, writings, images and sounds, or artificial intelligence (AI).

When people are not communicating online, they make use of phone calls, face-to-face conversations and written letters, depending on each situation. The same applies to online communication; people make use of instant messaging, social networking or email, depending on the situation. You can choose the mode of communication that best suits you.

The following table shows how different people communicate online. We asked Zanele, Linda and Vusi how they communicate online. Their answers were as follows:

**Table 12.1:** *How people communicate online*

		
Zanele	Linda	Vusi
I use instant messaging to chat to my friends and family. I use email to communicate to my teacher about assignments and questions I have.	I love my blog, I use it to communicate my ideas and hobbies to the rest of the world. I also use video calling to call my parents every week.	I use email to chat to my clients and other co-workers. I use text and picture messaging to communicate to my cousins in the USA.

In this chapter, we will look at e-communication using a PC, with specific focus on using and receiving emails.

### E-COMMUNICATION USING A PC OR MOBILE DEVICE

There are many ways in which to use electronic communication when you have an internet connection. The most common type would be electronic mail, which is usually referred to as email, but there are also other forms, such as video chat, discussion forums, Skype and instant messaging. In this section, we will look at the different applications that are used to facilitate electronic communication.

#### EMAIL

One of the first and most popular forms of electronic communication is email, which allows users to send messages and files over the internet. One of the best things about email is that you do not have to wait for weeks to receive it. This type of mail arrives moments after it has been sent.



#### Something to know

Have you ever tried to think how many emails are sent per day around the world? In 2017, an average of 269 billion emails were sent and received each day. In 2018, 124.5 billion business emails and 111.1 billion consumer emails were sent and received each day.



### Something to know

According to recent statistics, teenagers regard email as a more formal mode of communication and they usually use it for school or exchanging messages with adults. Teenagers find emails to be too slow and time consuming, compared to instant messaging.

Email is used in the following ways:

- Communicating with clients or with other employees
- Keeping in touch with friends and family
- Sending files as attachments to another person
- Sending marketing messages to potential clients

We will learn more about emails and how to send them a bit later in this chapter.

### MAILING LISTS

Jenny receives an email from Takealot.com every day before 05:00 with their latest sale items and items that they have on promotion. Do you think that someone is sitting in front of a computer sending emails at 03:00 to everyone that subscribed to this website? That is definitely not the case; they use a mailing list.

A *mailing list* is a collection of names and addresses used by an individual or organisation to send information or materials to multiple recipients. There are two main types of mailing lists:

1. **Response list:** This list consists of names and addresses of people who have responded to an offer of some kind. Because these people are known responders, their names are generally priced higher than those in lists compiled by other means.
2. **Compiled lists:** These lists contain the names and addresses of people obtained from telephone directories, public records, direct mail and telemarketing campaigns, etc. This information is sometimes also obtained from a list broker who researches, analyses and evaluates the many individual lists available.

Other types of mailing lists include the following:

- **Team list:** Mailing lists that teammates use to communicate with each other within their teams
- **Group list:** Mailing lists used by a specified group of people to communicate with each other, for example a list of the parents of each learner in the school
- **Event list:** Mailing lists communicating information around a specific event that is happening, such as the upcoming athletics inter-schools event

### INSTANT MESSAGING

The internet has changed the way in which we communicate, with email being the most popular form of electronic communication. However, sometimes even email is just not fast enough. Let's look at the following example to understand this better.

#### INSTANT MESSAGES

In the smartphone-obsessed world in which we live, more people are sending messages through web-based application, such as WhatsApp, WeChat, Slack, LiveChat, Hangouts, Lync, Telegram and Snapchat.

These applications are short messages that are sent and read in real time, allowing you to communicate much quicker than normal emails.

There are also browser-based type instant messaging applications that do not require downloading, for example Facebook and Gmail. These applications allow you to chat to your contacts whenever you are logged in.



### MOST POPULAR INSTANT MESSAGING APPLICATIONS

Watch the following video:



<https://www.dw.com/en/the-worlds-most-popular-instant-messaging-apps/av-40684764>

Chat and instant messaging are mainly used when both, or all of the people are online so that everyone can read your message instantly, hence instant messaging! An email, on the other hand, will not be seen until the recipient actually checks the email, making instant messaging much more efficient for quick messaging.

Instant messaging is an online chat that allows you to exchange text messages, symbols, pictures and even documents, in real time, over the internet. It also allows you to see if a friend or co-worker is online and apart from sending text messages and files, you can also enjoy video and voice chats.

Instant messaging usually includes a list of your contacts (called a “Buddy List”) which lets you see who is online. This type of messaging is best used when it is one-on-one communication, but it is possible to send several people messages at the same time.

## WEB BROWSERS

There are different types of web browsers available, such as Google Chrome, Mozilla Firefox and Internet Explorer. Without these web browsers, it will be impossible to view web pages and websites! In the past, users had to download the software application to their PC so that they can chat, listen to music and watch videos. Nowadays, all these things can be done by just opening the web browser. All you need to do is open a web browser to access a website so that you can communicate via social networks, forums, emails and popular instant messaging services.

Websites are also designed to communicate with the user; whether it is a shopping site that lets their visitors know they have a 70%-off sale, or a small blog where one person talks about the different recipes they try out.

## TEXT AND PICTURE MESSAGING

Text and picture messaging are very popular and are usually sent from one smartphone to another. There are, however, applications that allow you to text and send pictures from your computer to a smartphone, or the other way around. Text and picture messages are fast and only take seconds to reach the other person. It is also useful to text someone if it is not possible to call the person, for example if you are in a meeting or in class.

It is easy to send text, pictures or even voice messages through different applications, such as WhatsApp, SnapChat, Facebook, Hangouts and many more.

People can instantly send these forms of multimedia anywhere in the world and it does not cost much.

## VIDEO MESSAGING

Video messaging is an easy way to make inexpensive phone calls anywhere in the world and from your computer. It does not even require a very fast internet connection. Many instant messaging and chat services have voice chat and allow you to talk to friends who are online. Video chat lets you see and hear friends, family or clients in real time. Whether you are talking to a friend or someone at work, video chat can add a personal touch to your chats!



### MOST POPULAR ACRONYMS AND ABBREVIATIONS

To check the most popular acronyms and abbreviations when texting, click on this code:

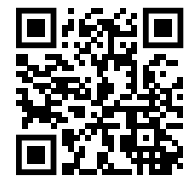

<https://www.netlingo.com/top50/popular-text-terms.php>



### Something to know

To decrease the cost of making voice calls, internet companies invented technologies that allow you to make voice calls over the internet (VOIP). Services, such as WhatsApp and Skype, allow you to make free voice calls to other WhatsApp and Skype users.

## WEBLOG

Have you ever wanted to create your own website, but never figured out how to? Well you can and best of all it is free and quite easy. Today, it is possible to create a website by creating a blog (short for weblog). So, what is a blog?

A blog is an online diary or journal that is located on a website and presented with the newest information first. It can contain text, pictures, videos, animated GIFs and even scans from old physical offline diaries or journals and other hard-copy documents. Although it is mostly run by individuals or small groups, it can also be run by an organisation, promoting itself and its products or services.

## FAX TO EMAIL

A fax (short for *facsimile*) is an exact copy of a document (text or images) that was scanned and transmitted as data by a telecommunication link. This usually goes to a telephone number that is associated with a printer, or other output device.

Fax-to-email, or email fax, is a system that allows users to send or receive a fax using email. This form of communication is used when you use the internet to send faxes. Basically, what happens is that the sender faxes the document using the receiver's fax-to-email number, who will then receive the fax as an attachment in his or her email inbox.



### Activity 12.1

1. Explain the term “e-communication”.
2. Describe an e-communication device and list three examples.
3. What do you understand by the term “mailing list”?
4. What application do you use the most to text and send pictures? How do you use text messaging?
5. Who normally uses blogs?
6. Vusi has no fax machine. However, his friend from Brazil must fax him a document that he urgently needs. His friend only has access to a fax machine.
  - a. What can Vusi do to make sure that he gets the document?
  - b. How do you think Vusi should go about doing it?

## 12.2 Email as a form of e-communication

Email is an electronic form of communication that is exchanged between people through computers, or other electronic devices, such as smartphones or tablets. You need the internet to send emails.

You also need software in the form of an email application that allows you to send, receive, forward and reply to email messages. With emails, you can also attach files, such as documents, photographs and even videos (restricted to a certain data cap).

In this section, you will learn more about email, how email addresses are written, and the features and tools that are included in having an email account.



### Something to know

You know that email is a way to send and receive messages using the internet. It is similar to traditional post, but with some important differences. The figure on the left shows what email is about, as well as its advantages.

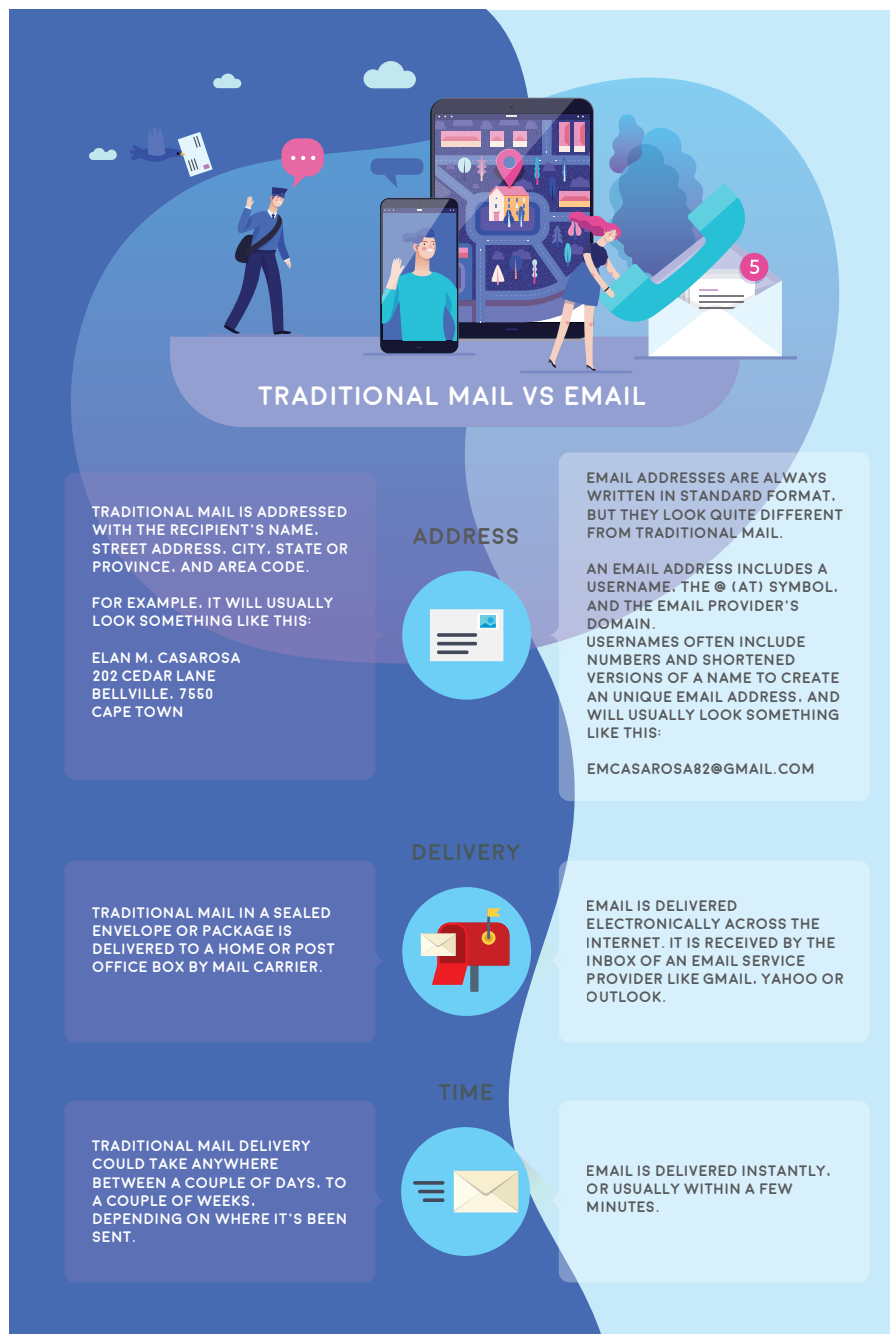

Figure 12.2: Traditional mail versus email

## COMPONENTS OF AN EMAIL ADDRESS

To receive emails, you will need an email account and an email address. To send emails to other people, you will need their email address details too. An email address is, therefore, the unique identifier for an email account.

It is important to understand how to type an email address correctly because, if entered incorrectly, it might not be delivered to the recipient, or it might even go to the wrong person!

Email addresses are always written in a standard format that consists of two parts, a local part or *username* and a *domain*-part, separated by an @ symbol. The local part is used by the receiving mail server to determine where the email must go and what must be done with it after it arrived at its destination.

These different parts are called an email's **taxonomy**. The taxonomy of the email address, `computer@mweb.co.za`, is explained below:

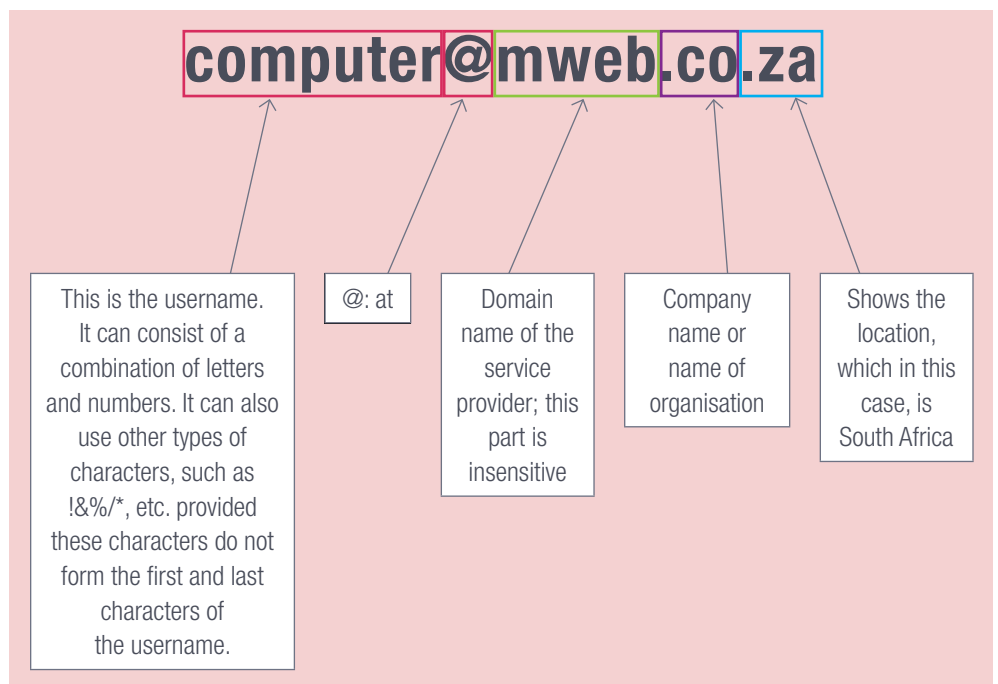

**Figure 12.3:** Components of an email address

## ISP VERSUS WEBMAIL

The first thing to decide when you are looking for an email service provider is whether to use a **webmail**, or to turn to an ISP to take care of your emails. As both have their advantages and limitations, it boils down to how much money you are willing to spend and the importance of maintaining your email.

**Table 12.2:** *ISP versus webmail*

	ISP	WEBMAIL
Advantages	The main advantage of having an ISP email account, is the support that you get when something goes wrong.	<ul style="list-style-type: none"><li>• Webmail does not charge for its services.</li><li>• Webmail refers to any email service that you can reach through a web browser. It also means that you can check for email messages on any computer with a web browser installed; whether you are at home, at work, or on holiday.</li><li>• You can also keep the same email address, even if you change your ISP.</li></ul>
Disadvantages	<ul style="list-style-type: none"><li>• An ISP provides a mailbox to end users as part of their paid services. When using an ISP, your emails will be on the ISP's servers. This means that you will have to connect to the ISP mail server to download your emails. If anything happens to these servers, there is no way that you can get your emails until the problem is fixed.</li><li>• If you have the wrong incoming or outgoing password, you will not be able to send or receive emails.</li><li>• ISPs charge for their services.</li><li>• Should you move or change your ISP, you will most probably have to get a new email address.</li><li>• There may be a limit to the amount of storage space for emails and attachments.</li></ul>	The main disadvantage is that it will send advertisements to your Inbox to help cover its costs. Some services, such as Gmail, will look for keywords in your email messages and show you relevant advertisements.

Top webmail providers currently are Google's Gmail and Microsoft's Outlook.com. They are the most commonly used as they allow you to access your email account from anywhere in the world, provided that you have an internet connection. You can also access webmail from a smartphone or tablet!

## HOW EMAIL WORKS

The following happens when an email is sent:

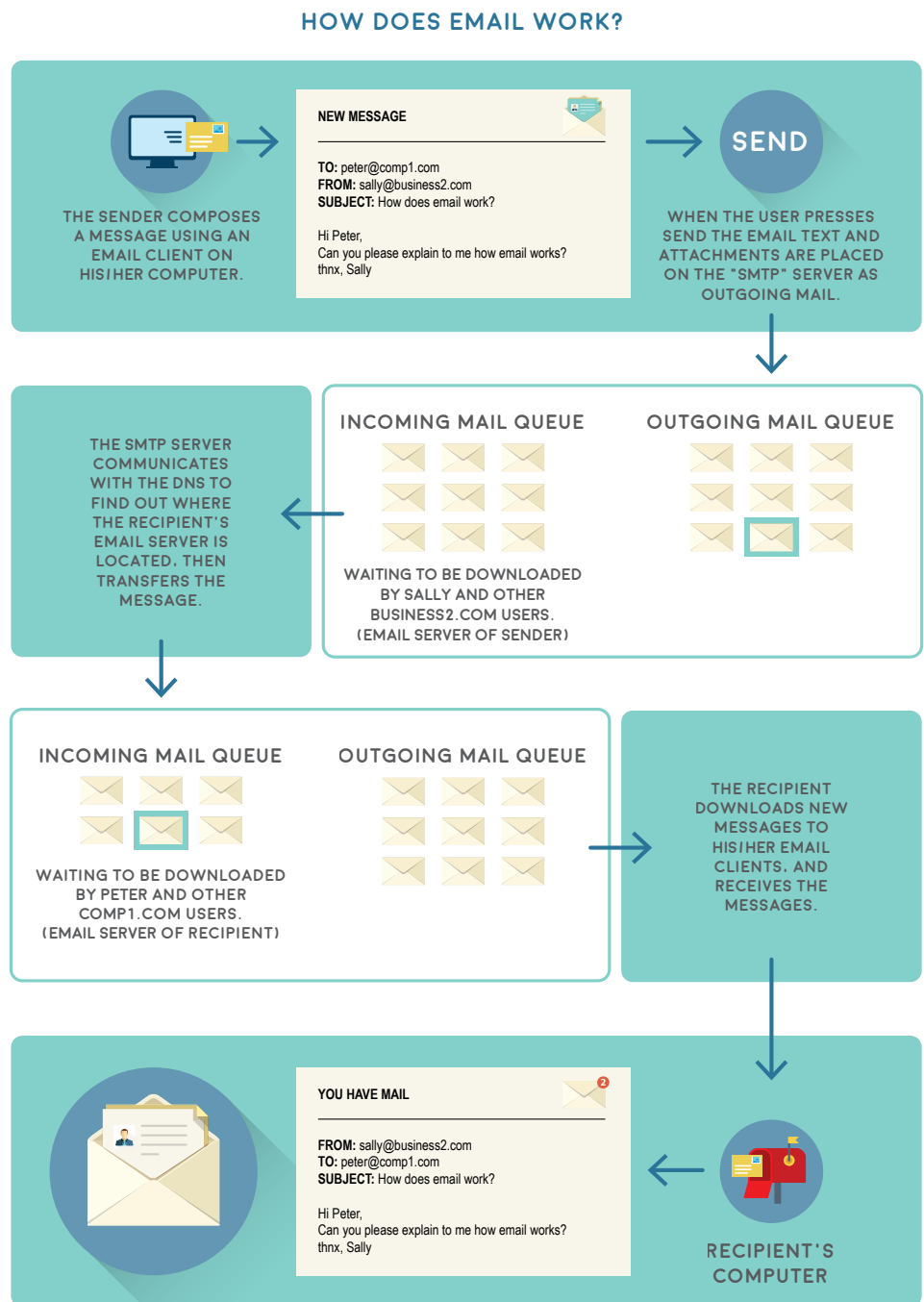

**Figure 12.4:** How email works



## Activity 12.2

1. Which of the following emails in the tables are valid or invalid? Explain why it is invalid each time.

EMAIL ADDRESS	VALID OR INVALID?	WHAT MAKES IT INVALID?
a. @domainsample.com		
b. anonymous@domainsample.com		
c. -autumn-dancer@domain.com		
d. jane.doe43@domainsample.co.uk		
e. janwa kitty@domain.com		
f. janwa_kitty@domain.com		
g. joesmith.nospamplease@nospam.example.com		
h. john.doe@.net		
i. john.doe@domainsample.ne		
j. john.doe43@domainsample		

2. What is the difference between an ISP email and a webmail?
3. Give two advantages and disadvantages of ISP and webmail.

## 12.3 Basic emailing

Before composing and sending email messages, you first need to know how to use an email account. In this section, we will use Gmail to show you the basics of using an email account. If you decide to choose another email provider, the interface might be different, but the basics will still be the same. You will learn how to:

- Sign up for an email account
- Navigate and familiarise yourself with the user interface
- Compose, respond, receive and forward email messages

In this section, we will look at the email interface, the terms and actions used in email, as well as features commonly used with email.

### EMAIL INTERFACE

Whichever email service provider you choose, you will still need to get to know the email interface. This includes the *Inbox*, *Message* pane and *Compose* pane. Although the interfaces will look different depending on the email provider, in the end, they all function in the same way.

### INBOX

The *Inbox* is where you will see and manage any emails that you receive. Emails are listed according to the date or time received, the name of the sender and the subject of the email message.

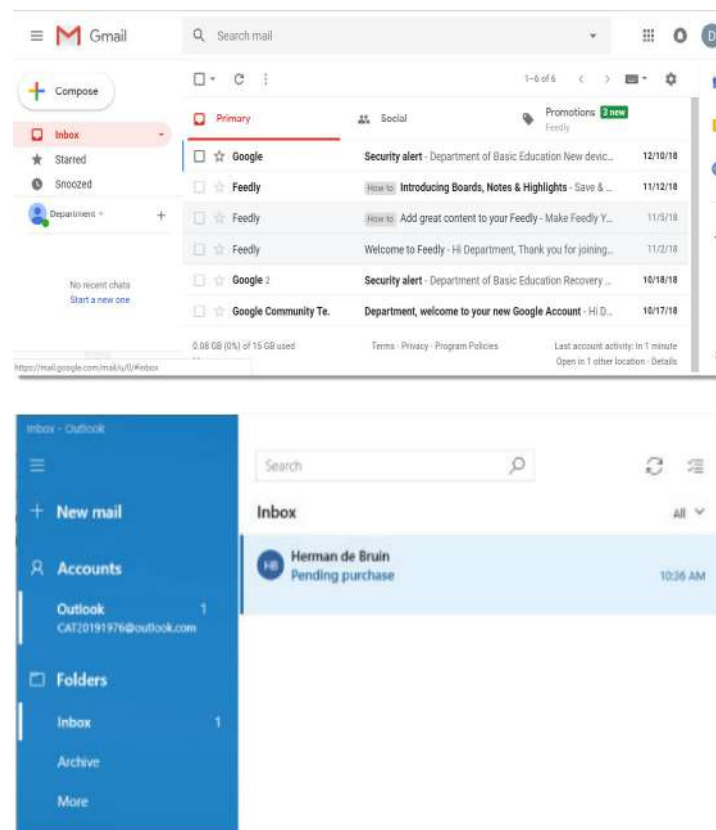

**Figure 12.5:** An example of an email interface

## MESSAGE PANE

After you select an email in the *Inbox*, it will open the *Message* pane where you can read it and then choose how to respond, using a variety of commands.

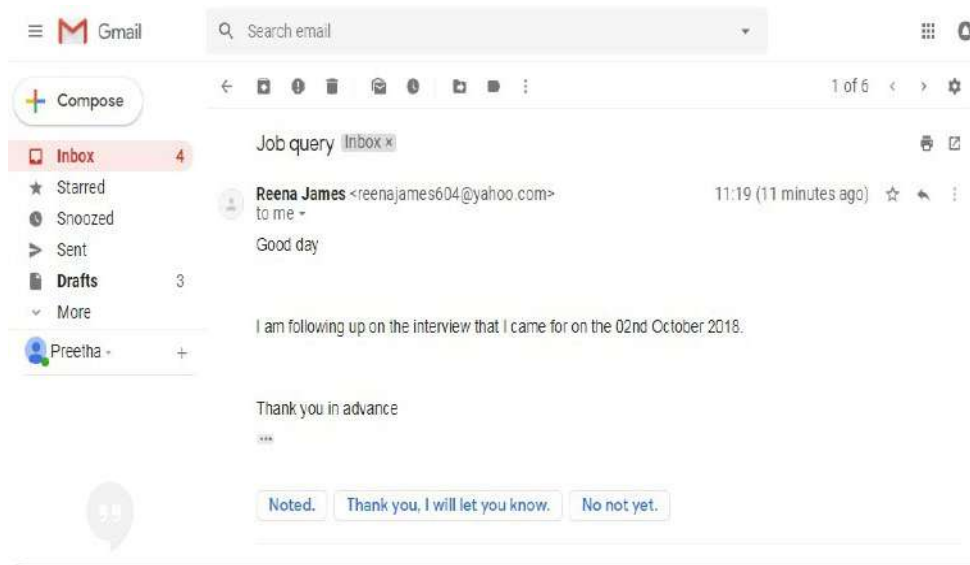
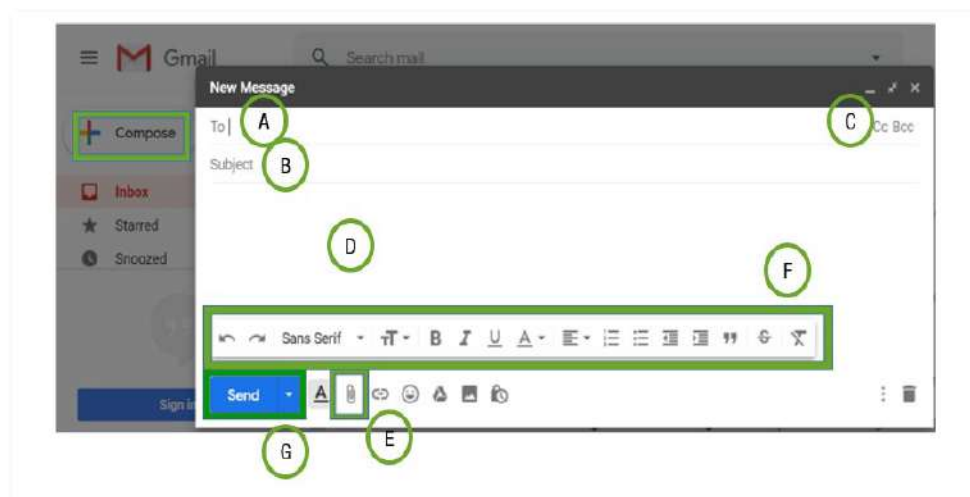

**Figure 12.6:** *The Message pane*

## COMPOSE PANE

When you click on the *Compose* button from the *Inbox*, it will let you create your own email message. From here, you will have to enter the recipient's email address and a subject. If you need to upload files, such as photos or documents, you can do that by adding an attachment.

Figure 12.7 shows the different parts of the *Compose* window.



**Figure 12.7:** *Compose a New message window*



### Something to know

If the details of person that you are sending an email to is already in your address book, then you can actually start by typing in the person's first name and Gmail will display the contacts below the "To:" field. Then press *Enter* to add the person as a recipient. This saves you time from actually typing in the whole address.



### HOW TO SEND AN EMAIL

Watch this video to understand how to send an email:



<https://youtu.be/2eH0JbEE-6k>

- A:** Recipients are the people to whom you are sending the email. For each recipient, you will have to type in the email address. In most cases, you will add recipients to the "To: Field", but you can also add recipients to the "Cc": or "Bcc": fields.
- B:** **Cc** stands for carbon copy and is used when you need to send an email to a person who is not the main recipient. It helps to keep everyone updated, but at the same time, it lets the person know that he or she does not need to respond to the email. **Bcc** stands for blind carbon copy. It is almost the same as Cc, but the email addresses in the Bcc fields are always hidden. This type of emailing is perfect if you need to send the same email to a large group of people, but keep their email addresses private.
- C:** The subject of the email is used to say what the email is about. The subject should be short, but clearly state what the message is about.
- D:** This is the body of the email. The body of the email is the actual text of the email, similar to that of a normal letter. It starts with a greeting, adds a paragraph or two and ends with a closing statement with your name at the end of it.
- E:** An attachment is a file, for example an image or document, that can be sent along with the email message by clicking on the *Attachment* button. Gmail allows you to attach more than one file, as long as it is not bigger than 25 Mb in total. However, by integrating its cloud storage service, Google Drive with Gmail, it is now possible to attach files as large as 10 Gb.
- F:** The *Formatting* button allows you to access the different formatting options for example, changing the font colour, look and size of the message, as well as include hyperlinks.
- G:** When you are happy with the message, you can click *Send* to send it to the recipient(s).

## SENDING EMAILS

Now that you have created an email account and understand how the email interface works, you can start sending email messages.

In this section, we will look at how to compose an email, add an attachment, reply and forward emails.

When you type an email, you will be using the *Compose* window. In this window, you will add the email address of the recipient(s), subject and the message itself. You will also be able to add one or more attachments in this window.



### Guided Activity 12.1

Do this activity in your class. Your teacher can help guide you in creating an email account. Use the account you created for this activity.

To send an email, you can do the following:

1. Click on the *Compose* button found in the left-hand pane.
2. The *Compose* window will appear on the right-hand side of the page.
3. In the "To" field, add one or more recipients. This is done by either typing in the email addresses manually, or by using the *Address Book*.
4. Type a subject for the email message.
5. Type a message in the body field. When done click *Send*.

## ATTACHMENTS

An attachment is a file, image, or document that is sent with the email. For example, if you are applying for a bursary, you can send your results and other documents as an attachment, while the body of the email serves as the covering letter. It is always a good idea to let the recipient know that you have attached a file or files.



### Guided Activity 12.2

Let's look at how to add an attachment. Do the following activity in your class with the help of your teacher.

1. When you are writing the email, click on the paperclip (attachment icon) icon at the bottom of the *Compose* window.

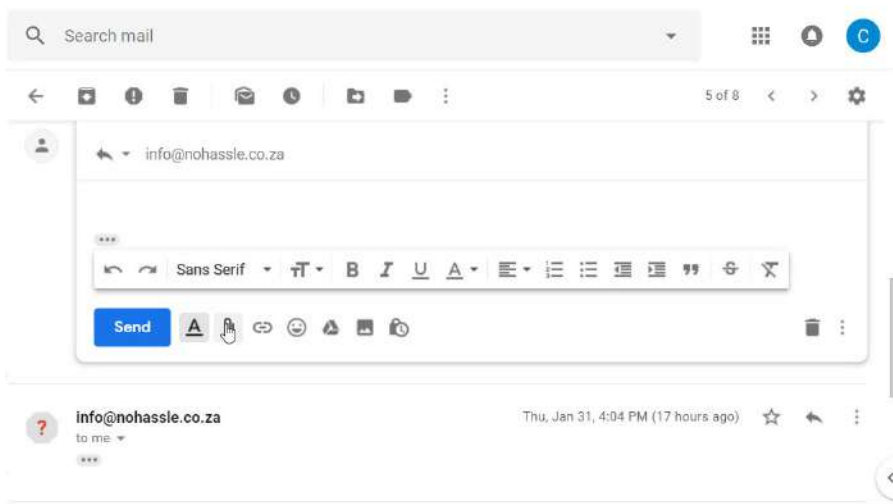

#### 12.8: Dialogue box with the attachment icon

A dialogue box will open with files that you can choose to attach.

2. Choose the file you want to attach and click *Open*.



#### 12.9: The Open window

... continued



### Something to know

Always remember to attach the file before sending it, it is extremely common for people to send an email without actually attaching the file!



## Guided Activity 12.2

... continued

The attachments will then start to upload. Most attachments just take seconds to upload. Large attachments can take longer.

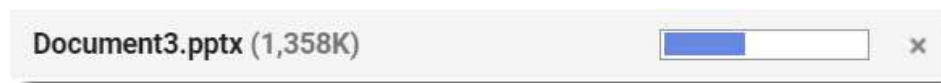

Figure 12.10: Upload status bar

3. When you are ready to send the email, just click *Send*.

You can click on the *Send* button before the attachment is finished uploading.

## REPLYING TO EMAILS

Emails are not only sent; they are received as well. After reading an email, there are certain actions you can take, for example, replying to the message, forwarding the email to someone else, or opening an attachment if there is one.

## READING EMAILS

Any email that you receive will be in the *Inbox* and you can tell which emails are unread, because they are marked in bold. From the *Inbox*, you can see the name of the sender, the subject of the email, as well as the first few words of the email. This means that, before you even open an email, you can already gauge a few things about it.



## Guided Activity 12.3

Do the following activity in your class with the help of your teacher. This activity will help you learn how to read an email:

1. Go to the *Inbox* and click on the email you want to read.

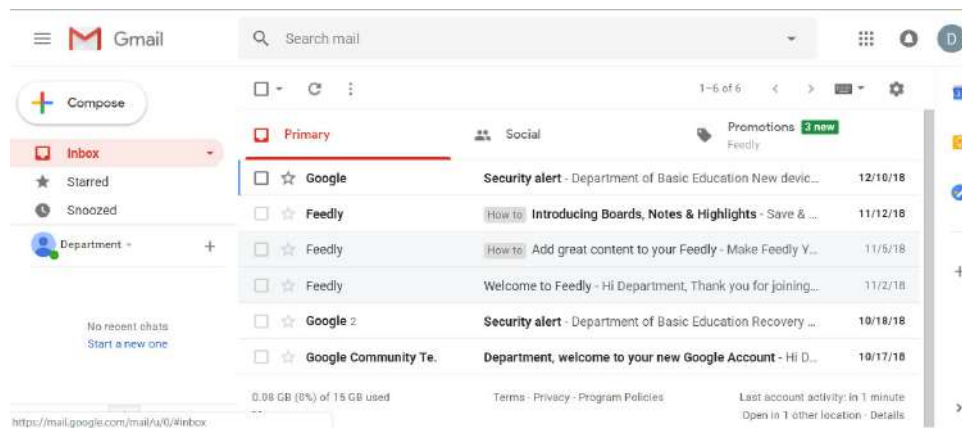

Figure 12.11: Inbox

... continued



The email will then open up in the same window:

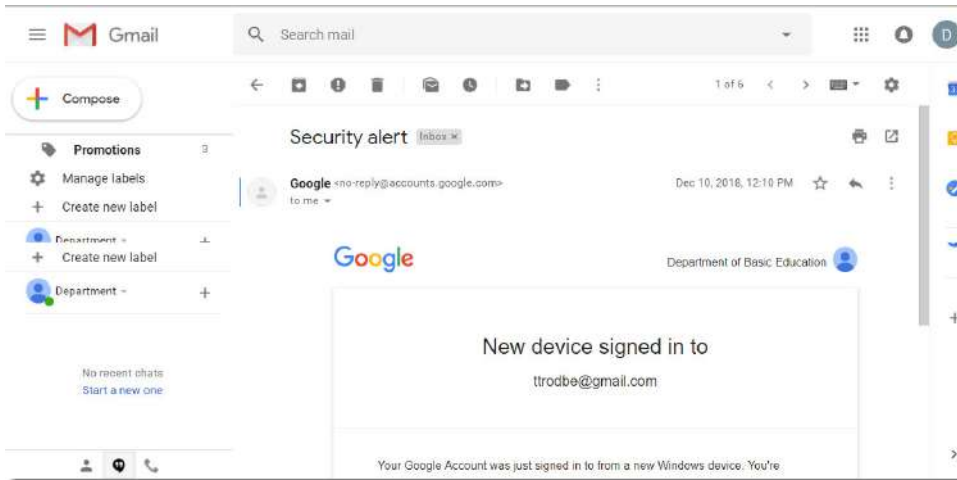

Figure 12.12: Opened email message

After reading the email, you can choose to *Reply*, *Reply to all*, or *Forward* the email to someone else. To perform any one of these actions, click on the three-dot icon found on the right-hand side of the email window.

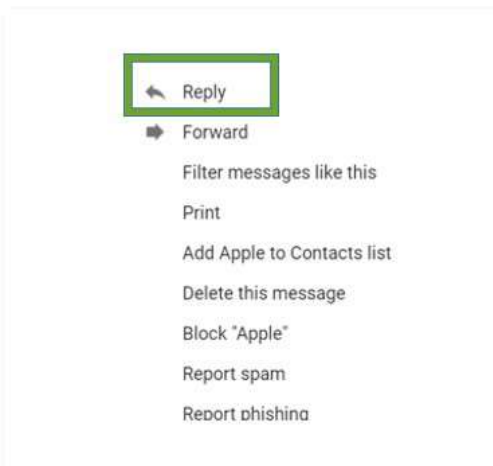

Figure 12.13: Reply, Forward and Reply to all

### REPLY, REPLY TO ALL AND FORWARD AN EMAIL

What is the difference between *Reply*, *Reply to all* and *Forward*?

Table 12.3: The difference between Reply, Reply to all and Forward in an email

TYPE	DESCRIPTION
Reply	When you click on <i>Reply</i> , this sends a response to the person that sent you the email. So, even if people were Cc'd in on the email, they will not receive the response.

... continued



## DEALING WITH EMAILS

To understand more about the different actions you can take after reading an email, watch the following video:



<https://youtu.be/a9e7XNo4agE>



## Something to know

You should only open attachments from a trusted source. Some attachments could contain a virus, especially if it ends with the .exe in the file name.



## HOW TO ADD A HYPERLINK

Have a look at these videos on how to add a hyperlink in Outlook and Yahoo Mail:



<https://www.youtube.com/watch?v=0FIFZ6-xuJc>



[https://www.youtube.com/watch?v=3iq00W\\_-uc0](https://www.youtube.com/watch?v=3iq00W_-uc0)

TYPE	DESCRIPTION
Reply to all	When you click on <i>Reply to all</i> , this sends the response to everyone that was a recipient, including those that were Cc'd in the original email. Take note that, if anyone was Bcc'd in the original email, they will not receive the response, even if you click <i>Reply to all</i> .
Forward	By clicking on <i>Forward</i> , this will send the message to one or more people (group) and will include any of the attachments that were initially included in the original email. The person or people to whom the email was forwarded, will see all the details that were in the original email. You can also edit the original message and remove any attachments before forwarding the email.

## ATTACHMENTS

There are times when you will receive an email containing attachments. To view the attachment, you will need to download it. In some cases, for example if the attachment is a Word document or an image, you can view it in the web browser.

In the *Inbox*, even before opening the email, you can tell if the email has an attachment by looking for a paperclip icon to the right of the subject.

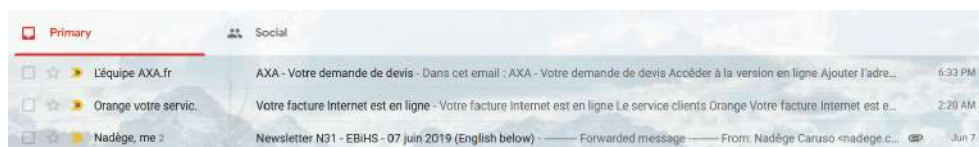

Figure 12.14: Attachment button

## HYPERLINKS IN EMAILS

Hyperlinks are added to emails so that the recipient can follow a link to visit a particular website or web page. Many businesses send emails with hyperlinks to promote or market their services or products. Note that the concept of how to create a hyperlink might be different in the various email applications.



### Guided Activity 12.4

Do this activity in your class with the help of your teacher. This activity will look at how to create a hyperlink in Gmail.

1. Sign into your Gmail account and compose an email to create a new message, or you can reply to an email that is already in the inbox.
2. Click on the *Link* icon in the Gmail toolbar, which is usually found next to the paperclip icon.

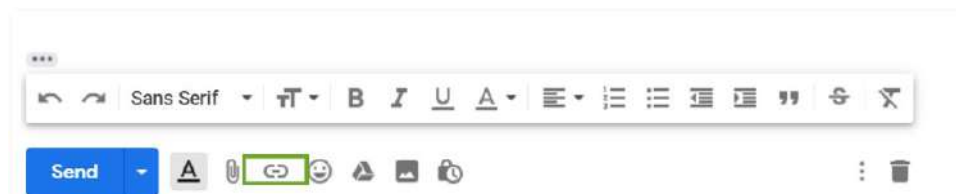

Figure 12.15: Hyperlink icon

... continued



- After clicking on the hyperlink icon, a dialogue box will appear asking you to insert the *Text to Display* and the *Web address*.

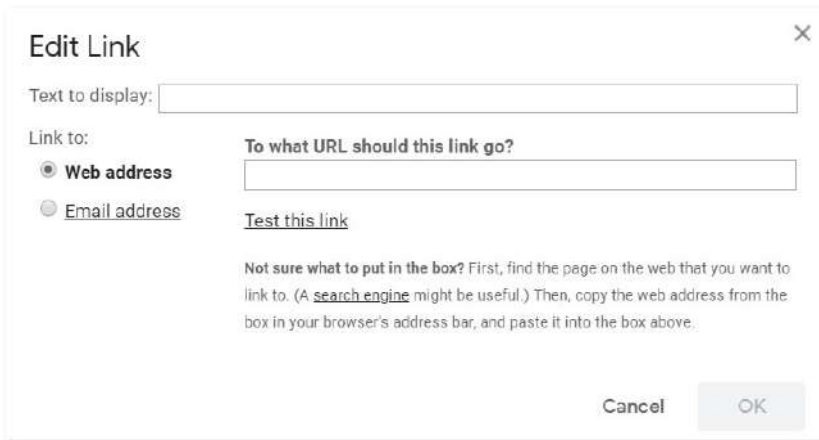

Figure 12.16: Dialogue box

- Enter the web address link you want the recipient to open in the *To which URL should this link refer?* field, such as "www.cnn.com".

Then enter the text you want the hyperlink to appear as in the *Text to display* field, such as *News*. Then click *OK*.

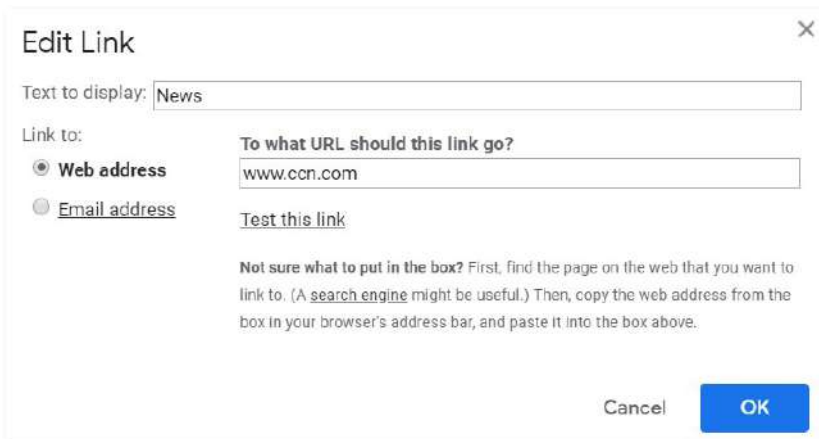

Figure 12.17: Adding a link

The link will then be added in the email, usually in a different colour and underlined so that the recipient knows that it is a link. The recipient can then click on the link and the link will open in another tab.

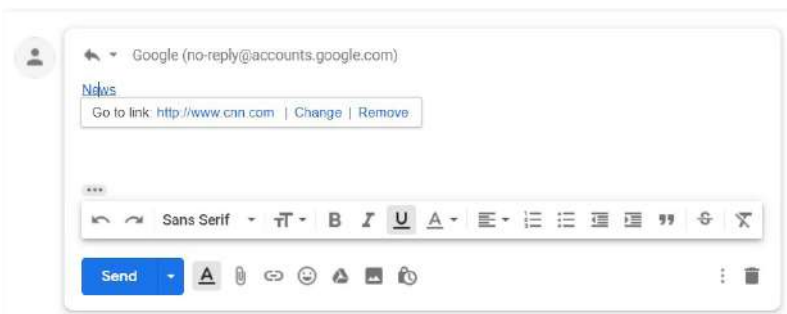

Figure 12.18: Link added



Something to know

By pressing *Ctrl+K* in Gmail, the hyperlink dialogue box will open immediately.

## ETIQUETTE IN EMAILS

As with any other form of communication, it is always important to practise good **netiquette** in emails. *Netiquette* is short for network and email etiquette. Netiquette means to use good manners when communicating electronically, or when using the internet; whether it is in the workplace, or on a personal level. It is also about respecting other people's privacy.

In this section, we will look at email etiquette, as well as why spelling is important when sending emails. Look at the following guidelines to practise good netiquette:

- **Messages:** Do not **spam** people at work, your friends or family with unwanted email messages or chain emails. Spam refers to unwanted or irrelevant messages that are sent over the internet or through emails.
- **Concise:** Make sure that when writing emails, they are clear and to the point. Also make sure that they do not contain spelling and grammatical errors.
- **Subject line:** Make sure the subject line is clear so that the recipient knows what the email is about.
- **Identify yourself:** Always say who and what you are at the beginning of the email and add a signature with your phone number at the end of the email.
- **Action required:** Let the recipient know right away if any action is required from his or her side. You can do this by marking emails that do not require any action with "FYI" in the subject line.
- **Capital letters:** Do not type emails in capital letters as it gives the recipient the idea that you are shouting.
- **Exclamation marks:** Avoid using exclamation marks or if really needed, use them sparingly. The use of exclamation marks sends a message to the recipient that you are demanding.
- **Large attachments:** Compress large files before sending them. This helps the recipient to save time instead of waiting for a long time to download files. You can always ZIP or compress files (as learned in Chapter 5) to make it easier to send.
- **Gossip, inflammatory remarks and criticism:** Avoid gossiping about others through email, especially at the workplace. Also, do not send insulting, abusive or threatening emails. You cannot withdraw such an email and it can easily be forwarded to unintended recipients. This could lead to unnecessary disputes and grudges in the workplace and in a personal environment.
- **Focus on what is in the email:** Make sure that you read the email properly and address the sender's questions.
- **Proofread the text:** Before sending the email, read through it again to make sure that it is saying what you want it to say and that there are no spelling and grammar mistakes.



### Case study 12.1

Julie works at a big auditing firm and deals with different clients on a day-to-day basis. She has made good friends with people at work, so occasionally she gets funny emails from them. However, she found one email to be extremely funny and decided to send it to her friend who works in another company. She just added the friend's name and after a few clicks, the email was sent.

In the space of five minutes, she got some out-of-office replies. She did not realise that she had sent it to all the staff in her department and worst of all, she sent it to her senior manager.

... continued



## Case study 12.1

This is an example of the email she sent.

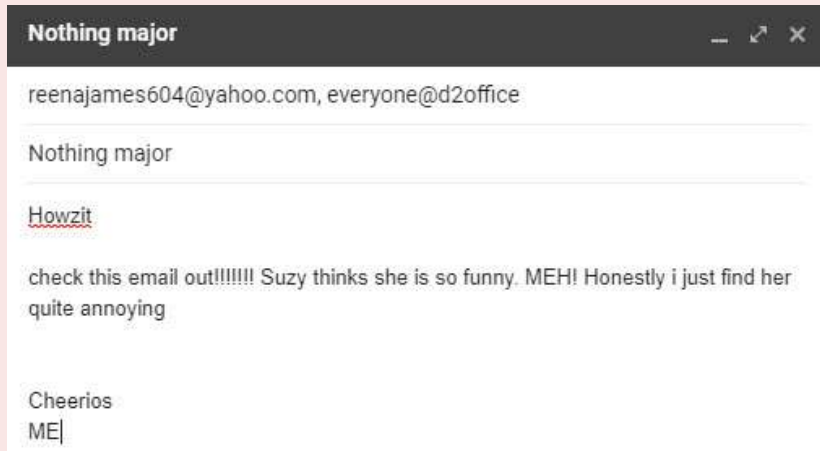

**Figure 12.19:** Julie's email that was accidentally sent to everyone in the office

1. What is the first problem with this email?
2. Discuss two email etiquette rules that are broken by Julie.
3. Explain what Julie can do to save her reputation.

## SPELLING AND EMAILS

Spelling is important in emails; whether it is emailing your manager, a co-worker, teacher, or even a friend. You need to make sure that you are sending an email that has no spelling errors. Sending an email with spelling errors does not reflect well on you.

Did you know that your email application has a *Spell Check* tool that is used to correct spelling mistakes when writing an email? In some applications, if a word is spelt incorrectly, it will be underlined in red or green wavy lines. By right clicking on the misspelt word, you can choose the corrected word from the *Context* menu.

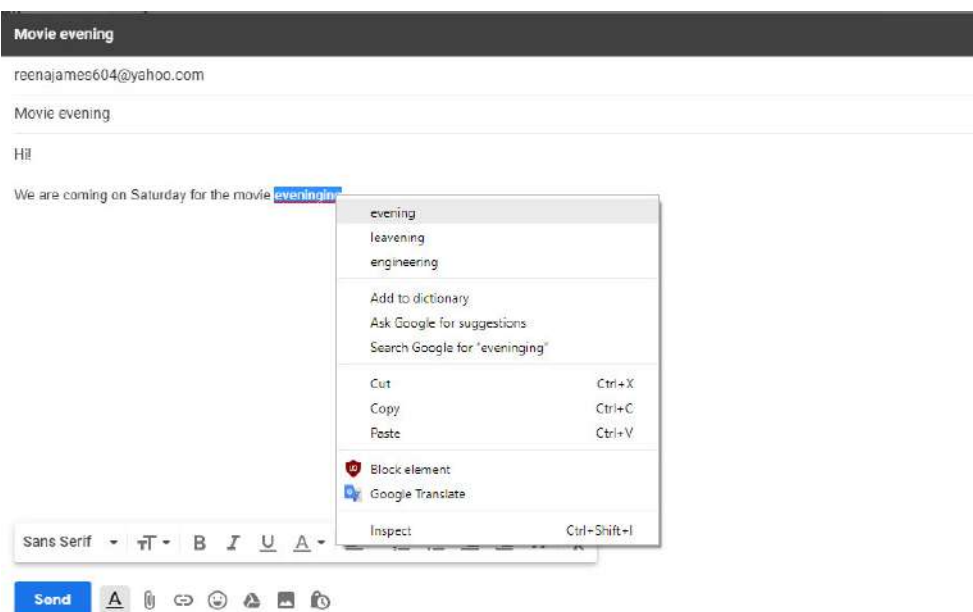

**Figure 12.20:** Spell checks



### Something to know

According to Emily Gorton, HR assistant at Powder Byrne Travel Agency, it is a cardinal sin getting someone's name wrong in an email. It shows a lack of interest and no attention to detail, and can negatively change a person's impression about the sender. The best thing to do then is to own up and apologise by sending another email as soon as possible.

It is always important to read the content and grammar of an email before sending it off. Something as small as making an error in someone's name, can make a very big difference in the way people perceive you.

In some email applications, you can enable the *Spell Check* function. This will automatically correct any spelling or grammatical errors.



### Activity 12.3

1. When sending a file as an attachment via an email, the email bounces back and displays the following message:

This is the mail delivery agent at [messagelabs.com](http://messagelabs.com).  
 I was unable to deliver your message to the following addresses:  
**Sales@telkomsa.net**  
 Reason: 552 Message size exceeds maximum permitted

- a. Why did the error message occur?
  - b. Briefly describe how the error can be fixed.
2. Study the following email:

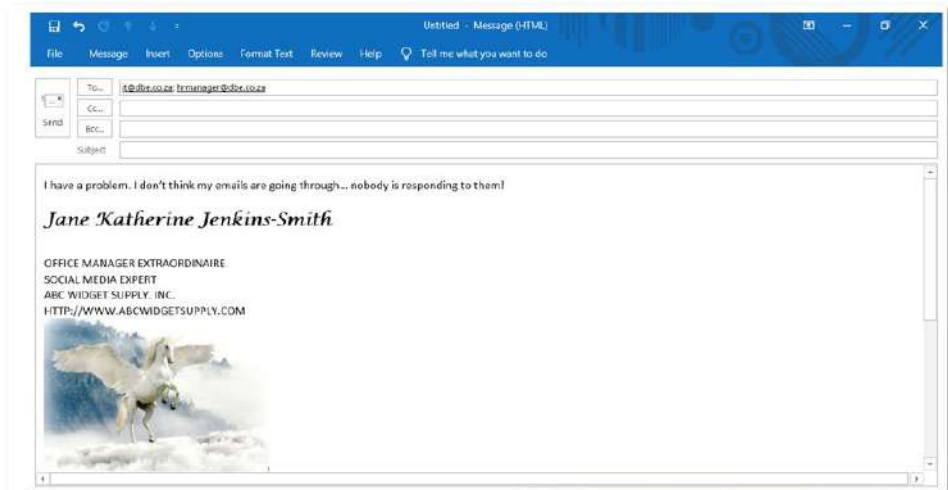

- a. Compare the **Cc...** and the **Bcc...** section in the email.
  - b. Consider the context of the email message on page 196 and list two email etiquette (netiquette) rules that have been violated.
3. Read the following scenario and answer the questions that follow:

The Motaung family's ISP is *Polkadot*. As part of their contract, the Motaung family receives one free email address. Should they need more email addresses, they need to pay an additional fee per month for each additional email address. Mrs Motaung's business's name is *Haybo! Catering*.

- a. Suggest a suitable email address for Mrs Motaung's business. Motivate why you suggested this email address.
- b. Suggest how Mr Motuang could get his own email address at no cost.

## REVISION ACTIVITY

1. Explain what is meant by “e-communication”. (3)
2. Write a short paragraph to explain the difference between email and instant messaging. (4)
3. Study the following screenshot and use it to answer the questions that follow:



- a. What is the username of the email address in the Bcc field? (1)
  - b. What is the domain name of the group to whom the email is being sent? (1)
  - c. The email address *designteam@weborg.co.za* is being sent to a mailing list. Explain what is meant by a mailing list. (2)
  - d. Will the members of the design team know that the email has been sent to their manager? Explain your answer. (3)
4. Innocent has two email accounts. The email addresses are *innocent25@gmail.com* and *inno.mhlebi@mweb.co.za*.
    - a. Which email address is a web-based email account? (1)
    - b. List one advantage and one disadvantage of having a web-based email account. (2)
    - c. What is the domain name of Innocent’s ISP? (1)
  5. Amahle is a long-distance runner who participates often in marathons.
    - a. Amahle would like to keep an online journal of her experiences. What e-communication application should she use? (1)
    - b. Mention two things that she could write about each day. (2)
  6. Study the screenshot of an email below and use it to answer the questions that follow:

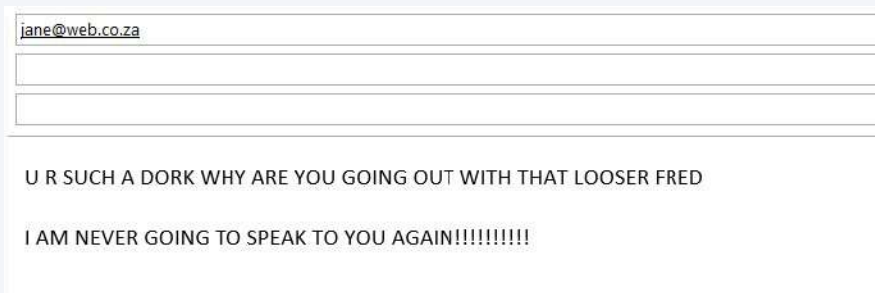

This email does not follow good netiquette.

- a. What is meant by “netiquette”? (2)
- b. Mention three ways in which the writer has not followed good netiquette. (3)

**TOTAL: [26]**

## AT THE END OF THE CHAPTER

Use the checklist to make sure that you worked through the following and that you understand it.

	DID YOU ...	YES	NO
1.	Learn what electronic communication is.		
2.	Identify the different electronic communication devices.		
3.	Learn what ISP and web-based mail are.		
4.	Learn about the advantages and disadvantages of ISP versus webmail.		
5.	Understand the different features of email, such as the “Cc” and “Bcc” fields, attachments, and address books.		
6.	Learn how to compose email messages.		
7.	Understand how to send, receive, forward, reply to and reply to all using email.		
8.	Learn about netiquette over email.		

# SOCIAL IMPLICATIONS: EMAIL AND INTERNET

## CHAPTER OVERVIEW

### Unit 13.1 Social implications: Email and internet safety

At the end of this chapter, you should be able to: 

- Identify email threats, issues and prevention methods.
- Use email and the internet safely.

## INTRODUCTION

The email and internet are not always safe and secure. You might receive emails from scammers and cybercriminals who are looking to get information from you, such as your banking information and passwords. You should, therefore, avoid storing any sensitive information, such as credit card numbers and passwords on your computer, or sending details to anyone asking for them. In this section, we will look at email threats and what you can do to ensure safe email and internet use.

## 13.1 Social implications: Email and internet safety

In 2015, a computer security firm called Kaspersky Inc. uncovered a computer attack by a group of Russian hackers against banks from around the world. These hackers used a “phishing attack” to infect computers on the bank’s internal network with a virus. Once they gained access to a bank employee’s computer, they used the computer to gain access to the security cameras inside the bank’s offices.



**Figure 13.1:** Cybercrime

The following table shows the common email and internet threats, as well as what you can do to protect yourself from potential threats.

**Table 13.1:** The most common threats

TYPE	DESCRIPTION	PROTECTION
Virus	A computer <i>virus</i> is any program that infects a user’s computer and acts in a way that will harm users without their knowledge. Users do not install viruses; viruses spread automatically, without the users knowing about them.	Keep software up to date, especially your antivirus software. Do not install or run any programs you do not know or trust. Do not download executable email attachments. Run a virus scan on any flash disk that you do not know, before using it.
Trojans	A <i>Trojan horse</i> is another type of virus that pretends to be a useful piece of software. However, once you install it, the Trojan horse infects the computer and can damage it in many ways. One of the most dangerous types of trojan horses is called a <b>keylogger</b> , which records every key you press on the computer and sends the information to a hacker on the internet. This allows the hacker to easily figure out your internet usernames and passwords.	The easiest way to protect yourself from Trojan horses would be to NOT open any emails, or download any attachments from unknown sources. Delete these messages to take care of this problem. Also, by installing antivirus software, this will scan every file that you download to protect you from these types of threats.

... continued

TYPE	DESCRIPTION	PROTECTION
Worms	A <i>worm</i> is a type of virus that can travel from one computer to another computer, without any human interaction. Worms make duplicates of themselves and can send thousands of copies to computers on the same network. This allows worms to quickly spread over networks, making them very difficult to remove!	To prevent worms, you should not click on any links on emails from unknown sources, or even instant messages. Avoid downloading attachments from emails and instant messages from unknown sources. Also, install antivirus software, with a software firewall so that it can block any potential threats from the network.
Hoax	<i>Hoax warnings</i> are used by people as “scare alerts”. Hoax warnings are passed on by users who think that they are helping other people by spreading the warning. The most common virus is the “email hoax”. The email will probably notify the recipient that there is a new destructive virus and that they should pass on this email to everyone in their address book. This results in thousands of unwanted emails that overload the system.	To protect yourself from hoaxes, do not open any emails, or download any attachments from unknown sources. Delete these messages to take care of this problem. Also, by installing antivirus software, this will scan every file that you download to protect you from this type of threat.
Phishing and email spoofing	<i>Phishing and email spoofing</i> attacks try to obtain sensitive information (such as usernames, passwords and banking details) by sending emails to users that look like official emails. These emails will either directly request the sensitive information, or redirect users to an official-looking website from where their information will be stolen.	Never send sensitive information, such as usernames and passwords over email. No company will ever ask for this information via email or phone. Make sure the email address and domain name are correct for any email that looks suspicious.
Pharming	Much like phishing, <i>pharming</i> attacks create an official-looking website that requests sensitive information. A very common pharming attack allows users to “change” their passwords. Instead of changing their passwords, the user’s username and password are recorded and their account is taken over.	Do not follow any links to change your password, unless you have requested the password change. Verify the domain name and web address of any website that requests sensitive information.
Ransomware	<i>Ransomware</i> is a particularly malicious virus that locks all of a user’s files. Thanks to the strong encryption, it can be physically impossible to unlock these files on your own. The only way to gain access to the file is by paying the virus creator a specific amount of money (usually around R3 000) within 72 hours.	Ransomware is simply a virus; so the same advice applies to ransomware. If your computer is infected with ransomware, do research online to find out what happened to other users who either paid, or who did not pay the ransom and then decide if your files are worth the amount being asked.



## UNDERSTANDING SPAM AND PHISHING

Have a look at this video to understand more about spam and phishing:



<https://youtu.be/NI37JI7KnSc>



### Something to know

Computer crimes are also referred to as “cyber crimes” or “e-crimes”.

## COMPUTER CRIMES

Although ICTs are useful, various computer crimes can take place if you are not careful enough. In this section, we will look at the following different types of computer crimes:

- Information theft
- Data theft
- Identity theft

### INFORMATION THEFT

Information is one of the most valuable resources available to people who are looking to exploit or cause others harm. These kinds of people commit fraudulent acts and can access personal information through hacking into someone’s computer files. We call them *cybercriminals*.

A cybercriminal can have access to the following types of information:

- **Personal information:** Personal information, such as your identity number, can be used to steal your identity. This allows the cybercriminal to open store accounts and apply for loans using your personal information.
- **Financial information:** Information about your banking details can give the cybercriminal access to your banking accounts, steal your money and do online purchasing.
- **Social media information:** If a cybercriminal has access to your social media accounts or information, the cybercriminal can exploit your friends and family by impersonating you. This can be done by sending a message to people asking them for money, or a message containing a virus that will allow the cybercriminal to exploit more people.
- **Interests:** Information, such as your likes and interests, can be very valuable as it can be sold to companies. The companies then use this information to tailor make advertisements and specials that are specifically aimed at you.

To avoid these problems, do not share your sensitive information unnecessarily and make sure to protect your information using a strong and secure password. While sharing information is part of using the internet, be selective about the websites with which you choose to share your information. If you use your email address for every website you visit, do not be surprised if you start receiving consistent spam emails.

### IDENTITY THEFT

*Identity theft* is when someone else pretends to be you. This is very similar to information theft. Here, the criminal is illegally obtaining information about you. This type of criminal can use information, such as your full name, date of birth, passwords, email address and bank card details to gain access to your bank account or smartphone.

Cybercriminals can use this information to steal money from you, or even sell your information to others.

## DATA THEFT

*Data theft* can refer to two different crimes. We will now take a look at each of these in some more detail.

The first is the theft of data caused due to a third-party gaining access and using your internet connection without your knowledge. To protect yourself against this form of data theft, you can do the following:

- Protect your network by using a username and password.
- Make sure to keep your username and password secret and do not share it with people you do not trust.
- If you suspect that someone has obtained access to your network, change your username and password.

The second type of data theft is *hotlinking*. Hotlinking is when someone takes a file or video from their website and links it to your website. This is problematic, as each time a user clicks on the link to download the file or view the video, your bandwidth will be used.



### Activity 13.1

Mrs Abrahams loves shopping online. She surfs the internet and every week, she purchases something new. One day she realised that there were purchases made that she did not make herself.

1. Explain how ICTs have benefited Mrs Abrahams in this context.
2. List one disadvantage of ICTs used in this context.
3. Briefly explain what Mrs Abrahams could possibly be the victim of.
4. Suggest what she can do to remedy the situation. Motivate your answer.

## SAFE INTERNET AND EMAIL USE

To avoid most of these problems, computer experts suggest the following rules:

- **Use a secure password:** A good way to create a secure password is to use three or four randomly selected words as your password. Also, include numbers and symbols. “Correct!Horse2Battery&Staple” for example, is easy to remember and difficult to hack.
- **Pay careful attention to the websites and links you open:** Make sure you know where a link is taking you to and verify that the web address is the same as the website you expected to visit.
- **Do not share sensitive information unnecessarily:** While sharing information is part of using the internet, be selective about the websites with which you choose to share your information. If you use your email address for every website you visit, do not be surprised if you start receiving reams of spam emails!
- **Do not open suspicious emails:** You can identify suspicious emails when they are from unknown or suspicious email addresses, emails that seem too good to be true, emails that request sensitive information, emails with executable attachments and emails with poor spelling or grammar.
- **Do not download suspicious programs or attachments:** If you do not know who the sender of the email is, never download the attachment. Even if you know who the sender is, but you are not expecting an attachment, do not open it. Your friend may have been hacked and sending a virus!
- **Keep antivirus applications up to date:** The antivirus application is your last line of defence against viruses. By keeping it up to date, you make sure that it knows how to detect all the latest security threats.

- **Keep other software up to date:** Software weaknesses or vulnerabilities can be used by hackers to gain access to your computer. One of the main reasons that programmers release updates, is to fix these vulnerabilities.
- **Use two-factor authentication whenever possible:** Two-factor authentication prevents anyone from logging into your accounts using just your username and password. Instead, it needs a second factor (which is usually a physical device, such as your phone) to access your account. This means that your account can only be hacked by a small number of people with access to your phone.



### Activity 13.2

1. Define the following email terms:
  - a. Hoax
  - b. Spam
2. Study this example of phishing:

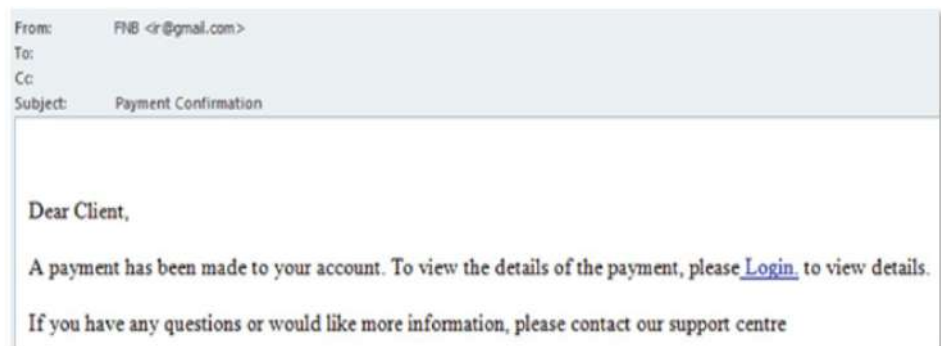

- a. Describe two features in the email that confirm the email to be a phishing attempt.
  - b. Explain the main difference between phishing and pharming.
3. Study the following extract from a case and answer the questions that follow:

Mike was the head of a new division of End Corp., a small company with about 45 PCs. Mike was hired to reduce expenses for the company and so he would only authorise the purchase of one copy of each software program that the company uses. His rationale was, “we bought it, and we can do what we want to do with it”.

*Adapted from: [http://www.siaa.net/index.php?option=com\\_content&view=article&id=338&Itemid=351](http://www.siaa.net/index.php?option=com_content&view=article&id=338&Itemid=351)*

- a. Identify the term that describes this extract.
- b. State one possible consequence for the developers of the software programs.
- c. State why the URL was provided in this extract.

### REVISION ACTIVITY

1. Write down only the letter matching the correct or best answer.
  - a. A worm is a type of virus that does which of the following?
    - A. Locks your files and demands that you pay money to unlock them
    - B. Spreads itself without human intervention
    - C. Hides your files away
    - D. Pretends to be a legitimate program

(1)

... continued

## REVISION ACTIVITY

... continued

2. Bandile is a Standard Bank client. He received the following message from them:

26 February 2019  
Good day

Welcome to our digital NEXT, and the old Online Banking site has been discontinued. Upgrade to continue Banking with a two-step sign in feature.

Click Here to sign in and upgrade, you will be required to first enter your email address and then your Password on the next screen.

Note: Registered phone number or Email address we have on our record must be confirmed as we will verify by sending One-Time-PIN to validate your details.

Gmail placed the message in a Spam folder and inserted the following message at the top of the email:



- a. What is this type of email called? (1)
  - b. Gmail disabled all the hyperlinks in the message. Why was this done? (2)
  - c. Mention one way that Bandile could recognise that this email was not legitimate. (1)
  - d. What are spam emails? (1)
3. Explain what a hoax email is. Does this type of email normally pose a threat? (2)
  4. Explain the difference between data theft and identity theft. (4)
  5. You have been asked to create a short presentation for your class on how to stay safe when using the internet and email. Write down five points that you would include in your presentation. (5)

[TOTAL: 17]

## AT THE END OF THE CHAPTER

Use the checklist to make sure that you worked through the following and that you understand it.

NO.	DID YOU ...	YES	NO
1.	Identify email threats and remedies.		
2.	Understand the different computer crimes.		
3.	Identify ways on how you can protect yourself from being a victim of a computer crime.		
4.	Understand the importance of using email and the internet safely.		

# INFORMATION MANAGEMENT

## CHAPTER OVERVIEW

- Unit 14.1 Concepts used in information management
- Unit 14.2 Practical Assessment Task (PAT) overview
- Unit 14.3 Sifting data
- Unit 14.4 Processing data
- Unit 14.5 Presenting data

At the end of this chapter, you should be able to:

- Understand data versus information.
- Describe the problem-solving steps.
- Explain how to gather data and information from different sources.
- Understand the difference between information and knowledge.
- Understand the importance of questionnaires and surveys.
- Sift out data.
- Process data.
- Present the data in the form of graphs or a report.

## INTRODUCTION

We are bombarded with a large amount of information on a daily basis. This information comes in many different forms. In order to gain knowledge and understanding, you need to know how to manage this information.

Information management (IM) is the process of gathering, selecting, processing and then presenting the information to people. In this chapter, we will look at data versus information, and how to understand a problem or task, as well as the importance of questionnaires. Lastly, we will look at different information sources and data-gathering tools.

# 14.1 Concepts used in information management

The information management process is used in every environment; be it at school or in a business. This process is used to determine if set goals are being achieved, or whether or not a company is making a profit. Managing information can be broken down into the following three steps:

1. Inputs
2. Processing
3. Outputs

Data is an example of input. In Chapter 1, we looked at data and information. You learned that data is raw, unorganised numbers, signals, or facts and by processing this data, it becomes information. Information consists of facts and numbers that have been organised so that they are useful for people.



### Case Study Tracking class performance

For example, if the Mathematics teacher wanted to see how well the current class is performing compared to last year's class, she might ask the school's database to convert its data into averages for the two years. That way, many pages of data are converted into two numbers that can be compared easily. Similarly, the report you receive at the end of each school year takes all the data that the teachers collected throughout the year and turns that data into a single report that you can use to measure your performance.

#### DATA

sector	message
00nl_Combined_Sector	14625
00nl_Combined_Sector	10125
00nl_Combined_Sector	4500
churches	1350
year	3150
00nl_Combined_Sector	5625
churches	4950
year	675
00nl_Combined_Sector	4500
00nl_Combined_Sector	1090

#### INFORMATION

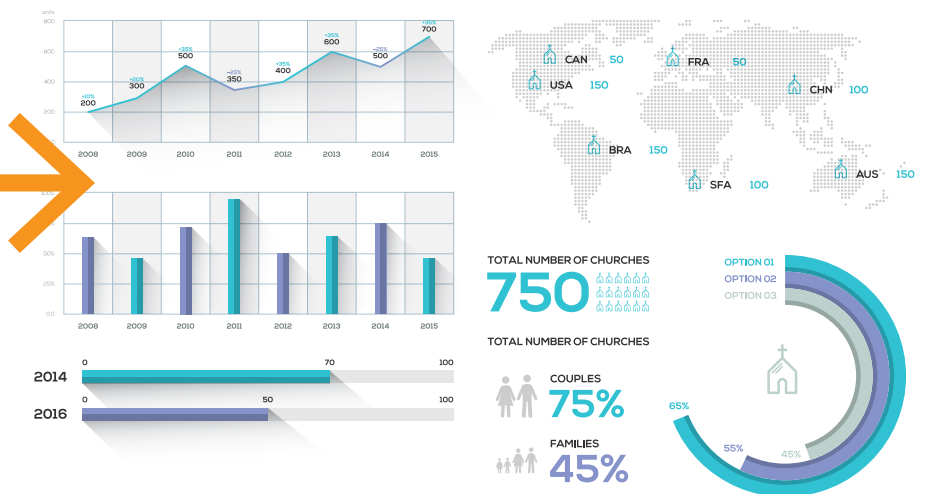



Figure 14.1: Data converted into information



The information management process in the Practical Assessment Task (PAT) can be broken down into the following phases:

- **Phase 1 – Inputs:** This phase is characterised by the gathering of *quality* information. For example, you have to research a specific topic. At this phase, you will have to create questions that identify what problems you will encounter with this topic. This will help you to understand the kind of quality information for which you will need to ask. After identifying the problems, you will need to get the relevant data and information from different sources. This could be in the form of printed media, or searching for information on the internet that you learned about in Chapter 6.
- **Phase 2 – Processing:** After gathering all the data (inputs), you will need to process it. You must understand what the information is and you will have to find solutions to the problems that you identified in Phase 1. For example, if you used a questionnaire, you will need to use a computer application like a spreadsheet to process the data and analyse the information.
- **Phase 3 – Outputs:** The last phase involves presenting that analysed information in the form of a report or presentation. Therefore, you will need to apply what you learned in word processing, spreadsheets and presentations in order to make the information understandable to other people.

## 14.2 Practical Assessment Task (PAT) overview

Before you can start a research project, such as the PAT, you must understand what the task is about. The purpose of the PAT is to test:

1. Your information management skills
2. Your application skills (to produce quality outputs using what you learned during the year)

Take note that the PAT is an important component in your year's marks. You need to complete the PAT on time; otherwise, it will affect your overall results.

### TECHNIQUES USED IN INFORMATION MANAGEMENT

There are different techniques used in the information management process. These techniques include identifying the task definition and information sources.

The PAT is usually broken up into three phases:

- Phase 1 (Term 2): Understanding the task, using information-gathering tools and using questionnaires to obtain data (input).
- Phase 2 (Term 3): Processing the data that you obtained in Phase 1, including using the knowledge you acquired earlier in the year (i.e. using spreadsheets) (processing).
- Phase 3 (Term 4): Presenting the information that you analysed in Phase 2 in the form of presentations or reports (output).

### UNDERSTANDING THE TASK

First of all, you need to understand what the topic is about, as well as what the task requires you to do.

It is important to manage your data and information effectively. You should ensure that you have a good filing structure.

### CREATING A GOOD FILING STRUCTURE

To make your life easier, create folders and sub-folders to store the data and information according to the three phases. Make sure you name all the folders and sub-folders correctly so that it saves you time and effort.

You can name the main folder using your name and surname, and name the three sub-folders Phase 1, 2 and 3, as shown below:



**Figure 14.2:** Folder structure

## TASK DEFINITION

The *task definition* given by the PAT will not explain the task in much depth. You will be required to interpret, as well as apply the instructions and problem definition given in the PAT.

It is important that you develop your own task definition written in your own words. When developing your own task definition, you can expand on the definition of the task by using mind maps or bulleted lists.

An example of a task definition is shown below:

I am doing this investigation to report to <insert target audience> about <insert PAT topic>.  
I will find information on <insert PAT topic>.  
I will use the following <source> <information-gathering tools> and create questionnaires to conduct interviews.  
I will also use the internet to help me find more information.  
After I have received all the data, I will use spreadsheets to process and analyse the data so that it converts to meaningful information.  
Using this information, I will then create a report. I will also use the questionnaire answers to create a report using a word processor.  
Lastly, I will translate the information into a slide presentation to show my <insert target audience>.

**Figure 14.3:** An example of a task definition

A PAT project requires you to think and apply your own creativity. When you are given a PAT project and before you can even start with Phase 1, you need to think of the following:

1. Read the PAT task scenario.
2. Write down what your initial thoughts are about the scenario.
3. Jot down the information that is given and required.
4. Identify a focus area that is related to the scenario.
5. Write down the possible sub-topics.

## PROBLEM SOLVING

*Problem solving* is the process of looking at a situation and finding exactly what the problem is, what the causes of this problem are, possible solutions, or how the problem can be removed.

In any problem or scenario where a decision must be made, there are steps that you can follow. The problem-solving process can be broken down into the following five steps:

1. Identify the problem
2. Understand the problem
3. Gather information
4. Find a strategy
5. Implement the strategy

You can ask yourself the following questions when identifying a problem:

1. What is the problem?
2. Is it my problem?
3. It is worth solving?

After defining the problem or task, you need to think about how to take the process further. You need to decide on how you will take on the task. The best way to do this is by finding the information. To get the information, you must ask yourself questions, such as:

- What, when, where and why?
- If, what if and how?

We just spoke about problem solving in general. In Phase 1 of the PAT, you need to identify the task that is given to you and set questions in order to help you investigate the task efficiently.

When setting questions, keep the following in mind:

- Questions can be arranged according to sub-topics.
- You can write down all your questions and then later categorise them according to their sub-topics.
- Questions can be arranged into levels and when sorting out your questions, you can sort them according to the question level.

**Table 14.1:** *Sorting questions into levels*

LEVEL	TYPE OF QUESTION
Level 1	These are questions that can be answered simply by the facts and starts with words, such as: What? When? Where? Who? How many?
Level 2	These are questions that help you explore or investigate and starts with the word, such as: Why? How?
Level 3	These are questions that will help you to predict or assume and starts with the word: 'If'. For example: <i>What if _____?</i>
Level 4	These are questions that will help you to review, or make a judgement or a conclusion of some sort and usually starts with questions, such as: Would it be better if _____? What recommendation? How can I determine what would be the best way?

#### INFORMATION SOURCES

Once you have an understanding of the task and have developed the task definition, you will need to gather data and information. In this phase, you must consult several types of information sources to understand the subject better.

Information can be gathered using the following sources:

- **Electronic media:** Web pages, e-books, the internet, online books and encyclopaedias
- **Printed media:** Books, encyclopaedias, journals and magazines
- **People:** Surveys, interviews and questionnaires
- **Other sources:** Social media and your own knowledge

**Table 14.2:** *The different types of information-gathering sources*

TYPE OF SOURCE	DESCRIPTION	ADVANTAGES	DISADVANTAGES
Electronic media	Data and information can easily be accessed on the internet. This can be done by using online resources, such as Wikipedia, Google searches and internet articles, books, and magazines.	<ul style="list-style-type: none"> <li>• A wealth of information available</li> <li>• Easily accessible</li> <li>• A variety of resources</li> </ul>	<ul style="list-style-type: none"> <li>• Lots of information to sift through</li> <li>• Time consuming when looking at specific types of information</li> <li>• Not all sources are accurate or reliable</li> <li>• Source can be removed and made no longer available</li> </ul>
Printed media	Data can also be gathered from printed media, such as books, newspaper articles, magazines and procedures.	<ul style="list-style-type: none"> <li>• Information can be stored and is available when needed</li> </ul>	<ul style="list-style-type: none"> <li>• Have to carry media around</li> <li>• Limited amount of information</li> <li>• Can sometimes be outdated</li> </ul>
Questionnaires	Questionnaires are a set of written or printed questions, usually with a choice of answers. They can be conducted online, or on paper. Questionnaires are usually constructed for the purpose of a survey or statistical study.	<ul style="list-style-type: none"> <li>• Reliability of the information can easily be verified</li> <li>• Cost effective</li> <li>• Data is received instantly if it is done online</li> <li>• Answers are usually easy to analyse</li> </ul>	<ul style="list-style-type: none"> <li>• Writing up a questionnaire with the correct questions can be difficult</li> <li>• Sometimes people do not elaborate when answering questions and might be limited to one-word answers</li> <li>• Respondents might not be easily reachable</li> </ul>
Surveys	A survey is the process of collecting information from a group of people.	<ul style="list-style-type: none"> <li>• Can be developed in less time than other data-collection methods</li> <li>• Cost effective</li> <li>• Can be conducted remotely, for example over the internet, on mobile devices, over email, or telephonically</li> <li>• Can collect data from a large number of people</li> <li>• A wide range of data can be collected, for example the attitudes, opinions, beliefs and values that people hold</li> </ul>	<ul style="list-style-type: none"> <li>• People may not necessarily give the most accurate, honest answers</li> <li>• Surveys with closed-ended questions may be less valid than other question types</li> <li>• Questions may be interpreted differently if they are not clear and, therefore, not give accurate answers</li> <li>• “Yes” or “no” answer options can limit the process of analysing the data</li> </ul>
Interviews	An interview is generally in the form of a formal meeting where a set of questions are asked face to face, over a software application such as Skype, or telephonically. Interviews can be conducted to find out if someone is suitable for a specific job, or a course of study, for example.	<ul style="list-style-type: none"> <li>• Information is reliable</li> <li>• Cost effective</li> <li>• Data is received instantly</li> <li>• Credibility of the information can be verified</li> </ul>	<ul style="list-style-type: none"> <li>• Creating an interview with the correct questions can be difficult</li> <li>• Sometimes people do not elaborate when answering questions and might be limited to one-word answers</li> <li>• Analysing responses can be time consuming</li> <li>• Respondents might not be easily reachable</li> </ul>

## MORE ABOUT INFORMATION-GATHERING SOURCES

In the PAT, you will usually be given the instructions to conduct a survey or questionnaire where you must interview people. They will answer the questions that you set in the questionnaire and you will then collect all the questionnaires and use the information gathered from the questionnaires for an important task when completing the PAT.



**Figure 14.3:** Example of a questionnaire

The following are tips on how to create questionnaires; whether it is on a Word document, or using an application, such as Google Forms:

- Try using existing questionnaires and adapt the questions to better suit the information for which you are looking
- Limit them to Yes/No questions
- Make sure that the response options make sense
- Ask questions in a logical order
- Ask one thing at a time
- Look for people who are actually willing to share information
- Make sure that the questions are short, clear and to the point
- Define difficult terms or spell out abbreviations
- Remember that the way you interview the respondent will determine the type of information gathered, the quality of the information and how much information you can gather.



### LEARN ABOUT INFORMATION GATHERING TOOLS

To learn more about information-gathering tools, have a look at this video:



<http://learn.mindset.co.za/resources/computer-applications-technology/grade-10/information-management/how-tos/01-information-sources-and-data-gathering-tools>



### Saving your documents

Always save copies of everything and remember to save all your documents in a good file structure. Another thing to note is that web pages should be saved in a folder and must be named “web pages”.



## Activity 14.1

This activity is broken down into three sections (Sections A, B and C).

### SECTION A

1. Use the instructions in the PAT and create a folder structure. Use what you have learned so far to create a folder structure.
2. Open Word.
3. Create a word-processing document.
4. Name this document: *PAT Phase1*.
5. Use the heading: *Task definition*.
6. Using the topic given below, create a task definition in the *PATPhase1* document.

Conservation is everyone's responsibility. Even if you don't spend a lot of time in nature or appreciate her beauty, everyone needs access to food, clothing, medicine, clean air and water, a variety of other resources you upon everyone's best interest to try to conserve natural systems.

Your school wants to inform learners about conservation issues, the importance of conservation and create an awareness to address these issues. The school management team wants you to investigate a conservation issue that may interest you. They also want a formal report on the investigation which they can use in their awareness campaign. The investigation should address a conservation issue/problem, the impact thereof, possible solutions and the role learners could play or any other interesting facts and statistics that will inform learners about this issue.

*(Extract from question paper DBE/PAT 2014)*

7. Create a sub-folder called *Task Definition* in the Phase 1 folder.
8. Save the Word document in the sub-folder.
9. Close the Word document.

### SECTION B

1. In pairs, brainstorm headings that you could use for the topic. Write down a list of questions that can be applied to each heading.
2. Open the *PAT Phase1* document. Choose the headings that you think will help you complete this project. Transfer these headings and questions into the *PAT Phase 1* document.
3. Save the document.

### SECTION C

1. Open another Word document.
2. Create a table. It should look similar to this:

	QUESTION	SOURCE OF INFORMATION	REASON
1.			
2.			
3.			

3. Transfer the questions that you developed in the previous section to this table.
4. Indicate the information source to answer each question.
5. Briefly explain why you think this is the best-suited information source for that specific question.
6. Save the document with the name: *Phase1Information*.
7. Save it in the correct sub-folder.

## 14.3 Sifting data

The information management process has three phases. This section will focus on the second phase, which is sifting the data that was received or obtained from the first phase.

### INFORMATION VERSUS KNOWLEDGE

You have learned about data and information. But now, what about knowledge? How are data, information and knowledge related? It is simple: knowledge is the information that a person has collected in order to make an analysis. Let's learn more about how we will be using *knowledge* in Phase 2 of the PAT.

### QUESTIONNAIRES AND SURVEYS

The PAT usually requires you to conduct a survey using a questionnaire to gather your input data. This is a crucial element, because it is here, where data is processed into meaningful information. Remember, bad data = bad information. You need the data obtained from the surveys and questionnaires to input into the spreadsheet application.

### SIFTING INFORMATION

Before you can start with sifting information, you need to use information-gathering tools to find data. After you have obtained all the data from the different information sources, then only can you look at which type of data is relevant and which is not.

If you have documents in an electronic format, you can use an application, such as a word processor or PDF reader to highlight important information.

When you start with finding information for your PAT, you will probably notice that there are many websites from which you can obtain information.

However, you need to go through all the available information. From there, you need to choose the information best suited to your topic. In the PAT, the instructions given will give you an indication of what the main objective of the project or task is. The sub-headings that you choose will usually indicate what information is useful. The processing of finding this relevant information is called *sifting information*.



#### Activity 14.2

1. Briefly explain the difference between information and knowledge.
2. Do you think questionnaires are important in the PAT?
3. Differentiate between a questionnaire and survey.

## 14.4 Processing data

Data manipulation is the process where data is changed to make it easier to understand or read. The third phase of the PAT focuses on processing and using the data that is sifted in Phase 2. This section will look at how to use data manipulation, data processing and then finally, presenting the information.

### KNOWLEDGE VERSUS INSIGHT/DECISION MAKING

Knowledge is the information that people collect in order to make an analysis. Decision making (wisdom) is when people put everything together and actually do something about it.

An example of decision making is when Teacher A realises that her learners are struggling with certain sections in the curriculum, especially in Term 2. This is when she needs to use this information and plan on how to remedy the situation.

### THE IMPORTANCE OF INFORMATION MANIPULATION

In order to manipulate the information that you have gathered, you can do the following:

- Identifying the core meaning, which means to identify the most important points of the information that you collected.
- Summarising the information in your own words and then adding your own conclusions or opinions.
- Using graphs, tables and illustrations to show the information you collected visually.

**Table 14.3:** *Processing data and information*

STEP	WHAT TO DO
Group	Group data according to the questions that you asked. You can highlight the important data or information that group it accordingly.
Create hierarchies	Organise the information in an order to see where the highlighted information or data belongs.
Calculations	Using the skills that you learned in spreadsheets, you can use counting items in the spreadsheet, for example how many learners bought chips from the tuckshop on Tuesday. Functions, such as <i>MIN</i> , <i>MAX</i> and <i>AVERAGE</i> are also useful in analysing data.
Using graphs	Graphs are a good way to represent data. This will be taught when you learn about spreadsheets.

For data to be manipulated, it needs to be sorted and grouped so that the next person can understand what it means. This can be done using spreadsheets. Spreadsheets are extremely useful in sorting out data and making it look more understandable.

Microsoft Excel is an excellent spreadsheet program that allows the user to store, organise, sort and analyse information.

## DATA HANDLING USING A SPREADSHEET

The results that you got from the questionnaires are a small sample of the responses that you can analyse on a spreadsheet. Unfortunately, the reality is that when it comes to data handling, people usually sit with hundreds and thousands of data items that they need to analyse.

With your PAT, however, you are only using a small sample of data to show that you are capable of processing much larger samples. At this stage, the questions that you come across when dealing with data handling would be as follows:

- How many?
- What is the most popular?
- What is the least popular?
- How many more than?
- What is the average?

## PROCESSING DATA USING A SPREADSHEET

One of the best attributes of a spreadsheet program is that it can do all the calculations for you by using formulas. This application is like a calculator and can add, multiply, subtract and even divide. We will now learn about the basics of handling data using a spreadsheet.

### MATHEMATICAL OPERATORS

Microsoft Excel uses the standard mathematics signs, such as the plus sign (+), minus sign (-), an asterisk to multiply (\*) and a forward slash when dividing (/).

In Excel, all formulas begin with a sign.

You can also use the formulae and functions in Excel to help you process data. You will have seen most of these functions in action in your practical lessons on Excel, however, a list of basic functions is given below:

- SUM calculates the total of a range of numbers
- AVERAGE gives the average of a range of values
- MIN returns the minimum value in a list of values
- MAX returns the maximum value in a list of values
- COUNT counts the numbers in a list of values

Although these functions let you interpret large sets of data, it is not very good for visualising the data. For that, you can use charts and graphs, which will be explained in the next section.

After you have gathered the information, you need to transfer the data to an Excel spreadsheet. From there, you should use the *COUNTIF* function to count the number of answers for each question.



## Guided Activity 14.1

1. Open the workbook: *SurveyData.xlsx* containing the answers obtained from a target audience.
  2. Create a new table with headings for each answer.
  3. Use the *COUNTIF* function to count the number of times a specific answer was given.
  4. Repeat Steps 2 and 3 for the answers obtained from any other respondents.
- You will then get a sheet with valuable information.

The screenshot shows an Excel spreadsheet with a survey data table and a summary table. The survey data table has the following structure:

Questionnaire number	Preferred source of information	Knowledge on subject	Knowledge on use	Interested in use	Available device	WiFi availability
1	Physical	No	No	No	Smartphone	Yes
2	Physical	Yes	No	Yes	More than one	No
3	Physical	No	No	Yes	Laptop	Yes
4	Digital	Yes	Yes	Yes	Tablet	Yes
5	Digital	Yes	Yes	Yes	Smartphone	Yes
6	Digital	Yes	Yes	Yes	Smartphone	Yes
7	Digital	Yes	Yes	No	More than one	No
8	Digital	Yes	Yes	Yes	More than one	Yes
9	Digital	Yes	Yes	No	Tablet	No
10	Digital	Yes	No	Yes	More than one	No
11	Digital	Yes	No	Yes	Smartphone	Yes
12	Physical	No	No	No	Smartphone	No
13	Digital	No	No	No	More than one	Yes
14	Digital	No	No	Yes	Smartphone	Yes
15	Digital	Yes	Yes	Yes	More than one	Yes
16	Digital	Yes	No	Yes	More than one	Yes

The summary table below the survey data table shows the results of the COUNTIF function:

Preferred source of information	Knowledge on subject	Knowledge on use	Interested in use	Available device	WiFi availability									
Physical	Digital	Yes	No	Yes	No	Smartphone	Laptop	Tablet	Kindle	More than one	Yes	No		
COUNTIF	12	5	5	8	6	11	5	6	1	2	8	7	11	5

**Figure 14.4:** Using the *COUNTIF* function in Excel

The information that you get after using the *COUNTIF* function allows you to use proper figures to answer the initial sub-heading questions.

## 14.5 Presenting data

After you have analysed the data, you need to put it into a visual form so that the target audience can understand the results better. This is usually done in the form of graphs, tables and reports. In this section, we will look at ways in which to visualise information.

### GRAPHS AND TABLES

There are different types of charts and you can choose which of them best shows the information. The line graph, bar graph and histogram, pie chart and Cartesian graphs are the four most commonly used graphs.

**Table 14.4:** Application for the most common graphs

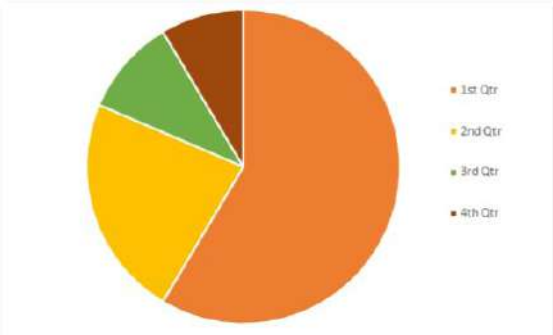
WHEN TO USE	EXAMPLE												
Bar graphs to show numbers that are independent of each other	 <table border="1"> <caption>Data for Bar Graph Example</caption> <thead> <tr> <th>Category</th> <th>Value</th> </tr> </thead> <tbody> <tr> <td>1</td> <td>38</td> </tr> <tr> <td>2</td> <td>40</td> </tr> <tr> <td>3</td> <td>46</td> </tr> <tr> <td>4</td> <td>56</td> </tr> <tr> <td>5</td> <td>68</td> </tr> </tbody> </table>	Category	Value	1	38	2	40	3	46	4	56	5	68
Category	Value												
1	38												
2	40												
3	46												
4	56												
5	68												
Pie charts when you are trying to compare the parts of a whole	 <table border="1"> <caption>Data for Pie Chart Example</caption> <thead> <tr> <th>Quarter</th> <th>Color</th> </tr> </thead> <tbody> <tr> <td>1st Qtr</td> <td>Orange</td> </tr> <tr> <td>2nd Qtr</td> <td>Yellow</td> </tr> <tr> <td>3rd Qtr</td> <td>Green</td> </tr> <tr> <td>4th Qtr</td> <td>Brown</td> </tr> </tbody> </table>	Quarter	Color	1st Qtr	Orange	2nd Qtr	Yellow	3rd Qtr	Green	4th Qtr	Brown		
Quarter	Color												
1st Qtr	Orange												
2nd Qtr	Yellow												
3rd Qtr	Green												
4th Qtr	Brown												
Line graphs to show how numbers have changed over time	 <table border="1"> <caption>Data for Line Graph Example</caption> <thead> <tr> <th>Quarter</th> <th>Value</th> </tr> </thead> <tbody> <tr> <td>1st Qtr</td> <td>8</td> </tr> <tr> <td>2nd Qtr</td> <td>5</td> </tr> <tr> <td>3rd Qtr</td> <td>3</td> </tr> <tr> <td>4th Qtr</td> <td>1.5</td> </tr> </tbody> </table>	Quarter	Value	1st Qtr	8	2nd Qtr	5	3rd Qtr	3	4th Qtr	1.5		
Quarter	Value												
1st Qtr	8												
2nd Qtr	5												
3rd Qtr	3												
4th Qtr	1.5												

... continued

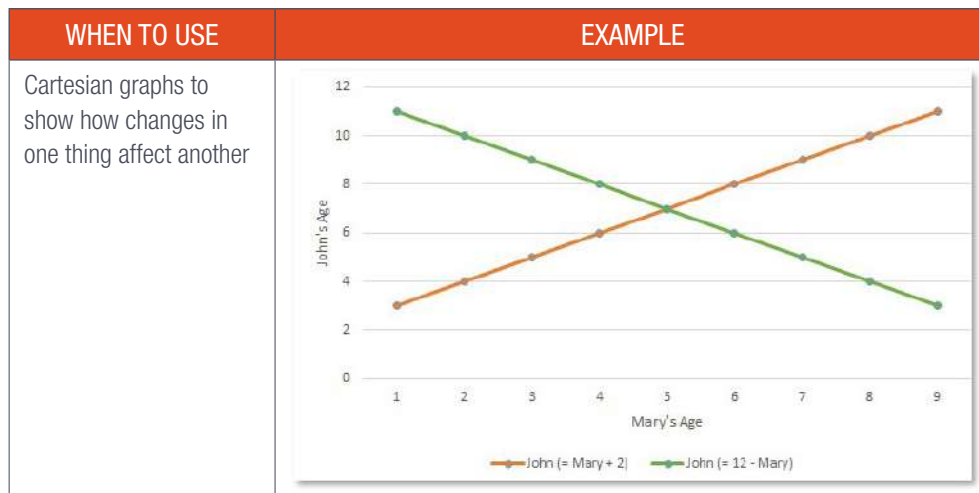

It is not always wise to put the graph on the same sheet as the data. It makes it cramped and might not be the easiest for a person to understand. Rather put all the graphs on the next sheet. It will make it easier for the PAT assessor to understand the information.

If you are unsure about what chart to choose, you can always go to the *Recommended Charts* tab that suggests the different types of charts based on the data.

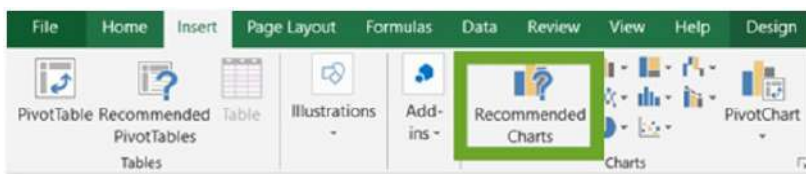

**Figure 14.5:** *The Recommended Charts tab*

## REPORTS

A *report* is another way of presenting information. It is a document that contains relevant information in an organised format. It helps us to clearly state the problem, the solution that was implemented to fix the problem, as well as how effective the problem-solving solution was.

A report consists of the following sections:

- **Introduction:** The introduction is used to state the purpose of the report and provide background on the issue. It is important that you make use of your knowledge on the subject to provide a clear description of the problem that has occurred and the solution that was implemented.
- **Body:** The body is used to describe the effect of the solution that was implemented. This can include a database containing all the data regarding the solution to the problem. However, simply supplying the data is not sufficient. You also need to process and analyse the data into useful information. The information should then be presented clearly and to the point. This can be done by extracting the core meaning of the data and writing it in your own words. You can make use of graphs and tables to help simplify the information.
- **Conclusion:** This section is used to indicate whether or not the solution was a success and if any other solutions might be needed. If the solution was not successful, you need to include which steps you are planning to follow in order to make sure that the problem is resolved.

- **Bibliography/References:** It is important to always reference the information that you use in your report. It shows the evidence of where you got the information from, how recent it is, the number of sources you used and if plagiarism was committed. You need to use a fixed method to correctly cite your references.

A reference list is a list of sources that were quoted in the report. A bibliography is a list of sources that were used for the report. There are different ways to reference; however, the most common method is the Harvard referencing technique and the American Psychological Association (APA) technique.

Always remember that it is important to draft the report as soon as possible. This is to ensure that you include all the details that you have observed. The longer you wait, the better the chance of forgetting something really important.

## PLAGIARISM

When writing a report, plagiarism is something that is really frowned upon. You learned about plagiarism earlier in this book.

Just to refresh your memory, plagiarism is a reproduction of someone's work as your own, without acknowledging the original source. This can be done in the form of directly using someone's findings (i.e. wording, sentences, or even the whole paragraph), pictures, etc., without referencing the original source.

When writing a report, make sure that you do not knowingly, or even unknowingly, publish or use someone else's work without acknowledging that person. To prevent plagiarism, you need to plan everything before drafting the report. Make sure you understand what the topic is about and how you are going to write the report.

It is extremely important to always hand in your own work. Therefore, when handing in your PAT, it is a good idea to hand in a declaration of authenticity, which indicates that you have not copied your work from someone else.

## COPYRIGHT

Copyright, as the name suggests, is the legal right of someone to make copies of something. It is a legal right originally given to creators and they can decide who and under what conditions, a person or company may copy their invention.

## INTELLECTUAL PROPERTY

Intellectual property is a term used to create something new or original. It can come in several forms. Examples could include any of the following:

- A new invention
- Design
- Brand
- Book or journal article

Using someone else's intellectual property without their permission is considered to be a crime.



### LEARNING ABOUT REFERENCING STYLES

Have a look at these videos to understand these two techniques a bit better:

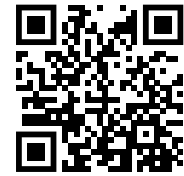

Harvard <https://www.youtube.com/watch?v=6RVrhIMUaS8>



APA <https://www.youtube.com/watch?v=wIOIOoMhDKc>



### Something to know

The PAT guidelines give you strict instructions on what the font sizes of the main headings and body text should be. If not stipulated, however, you can use a font size of 16 pt or 18 pt for the main headings and a font size of 11 pt for the body text.

## SLIDE SHOW PRESENTATION

The slide show that you need to develop for the PAT covers the same information as the report that you compiled. However, the presentation only deals with the key points and looks at the information very briefly. So, when creating a presentation, you need to think about which points are the most important.

## FINALISING THE PAT

When you hand in your PAT, make sure you take note of the following:

1. Check that you have done everything that was required of you by using the marking checklist.
2. Proofread your work and make sure that your work does not have spelling and grammatical errors. If you find errors, fix them.
3. Check that all the sources have been referenced and cited properly.
4. Check the layout of the documents; how the documents look actually makes a big difference. Make sure the layout, fonts and graphs all look visually appealing.



### Activity 14.3

1. List two different types of information sources.
2. Illustrate the difference between wisdom and knowledge by using an example.
3. Study the information presented in the following graph:

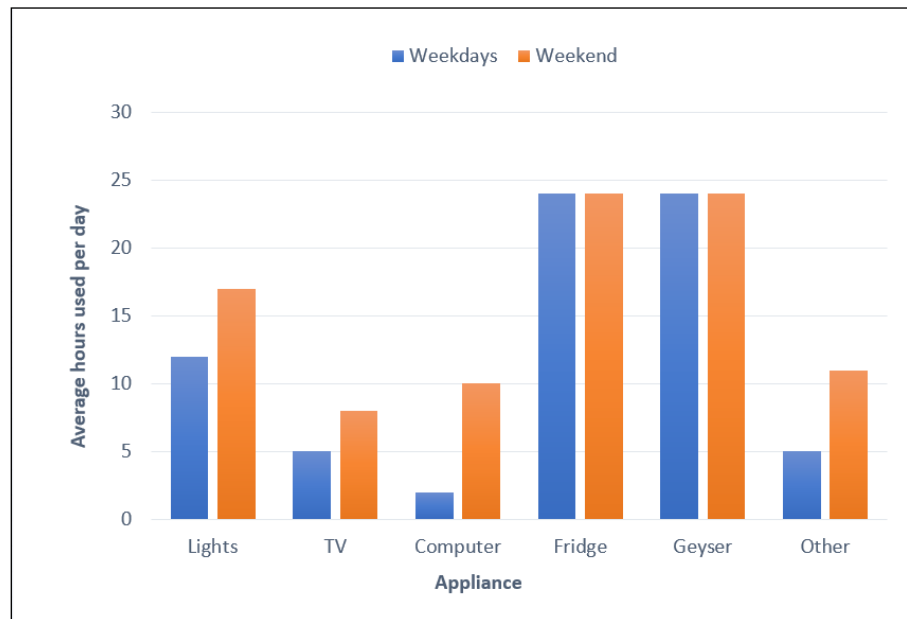

- a. Describe what the graph measures.
- b. Name the appliance with the least total usage.
- c. After the refrigerator and the geyser, name the appliance that is used most on week days?
- d. State why most appliances are used more during weekends than during the week.
- e. What advice will you give to households if they want to save electricity? Motivate your answer.
- f. List three different types of actions that you could perform on data to extract information, in other words, help to interpret it, or make sense of it.

## REVISION ACTIVITY

1. In the 2018 PAT, Grade 12 learners were required to investigate the topic of fake news.

### TOPIC 2 – FAKE NEWS

***Fake news is a type of news that consists of deliberate misinformation or hoaxes spread via print and broadcast news media or online social media.***

***There is a huge amount of interesting discussion happening about the spread of fake news on the Internet, including how to determine if news is fake or not, and what we as individuals and companies like Facebook, Google and Twitter, among others, can possibly do to minimise the effects of it.***

Your task is to:

- Investigate the current situation in **South Africa** at a national, provincial or local level
- Gather and analyse data relevant to the investigation
- Identify possible problems and solutions to any of the problems related to the topic you choose
- Identify a suitable audience (such as a school, your local community forums or business leaders) and present your research and findings in a report that would be suitable for use by the specific audience

Investigate how this topic affects the community in terms of:

- The existing problems and challenges we face in terms of this topic
- The impact in the local community, province or country
- (Partial) solutions for individuals, publishing companies, social media, et cetera

Source: <http://ecdoe.co.za/documents/learners/self-study-guides/pat-cat-english>

2. Use the information above and the following outline to write a task description for the PAT.

I am doing this investigation to report to <insert target audience> about <insert PAT topic>.

I will find information on <insert PAT topic>.

I will use the following <source> <information-gathering tools> and create questionnaires to conduct interviews.

I will also use the internet to help me find more information.

After I have received all the data, I will use spreadsheets to process and analyse the data so that it converts to meaningful information.

Using this information, I will then create a report. I will also use the questionnaire answers to create a report using a word processor.

Lastly, I will translate the information into a slide presentation to show my <insert target audience>.

Replace all the phrases between angle brackets <...> with suitable words that will match the topic of fake news. (6)

3. Thandolwethu is doing research into healthy eating habits amongst the learners in her class. She conducted a survey by asking each learner to pick their favourite vegetable from a list that she gave them. The number of votes that each vegetable received were tallied up. She then drew a graph to illustrate the votes for each vegetable.

... continued

## REVISION ACTIVITY

... continued

The following table shows the results that she obtained:

VEGETABLE	NUMBER OF VOTES
Peas	1
Carrots	3
Potatoes	16
Broccoli	0
Lettuce	5
Tomatoes	12
Sweet potatoes	5
Green beans	2
TOTAL	44

- a. Use this scenario to explain the difference between data and information. (4)
  - b. Thandolwethu conducted a survey to obtain her results. Explain the difference between a survey and a questionnaire. (4)
  - c. What sort of graph (chart) would best illustrate the above results? (1)
  - d. Use Microsoft Excel to draw a graph (chart) of Thandolwethu's results. Make sure the graph is easy to understand. You should not include the TOTAL on your graph. (4)
  - e. List two pieces of information that Thandolwethu obtained from her results. (2)
4. Chloe used a questionnaire as part of her PAT. Some of the questions had "Strongly Agree", "Agree", "Disagree", "Strongly Disagree" as options for her respondents to select. She captured the responses from each person in a spreadsheet. Which spreadsheet function should she use to determine the following?
- a. The number of respondents who answered each question (1)
  - b. The most popular response for each question based on the number of responses (1)
  - c. The number of respondents who answered "Strongly Agree" for each question (1)
5. List the four main sections of a report and state briefly what should be included in each section. (4)
6. Ntombikayise has copied and pasted three paragraphs of text taken from an online publication, into her report.
- a. She did not acknowledge the original writer of the text in her report. What is this known as? (1)
  - b. How could she use the information without making the mistake mentioned in (a)? (2)

[TOTAL: 31]

## AT THE END OF THE CHAPTER

Use the checklist to make sure that you worked through the following and that you understand it.

NO.	DID YOU ...	YES	NO
1.	Learn about the different stages in the information management process.		
2.	Learn about the problem-solving process.		
3.	Learn how to create a task definition.		
4.	Understand the different information-gathering tools and how they can be used.		
5.	Understand the connection between data, information and knowledge.		
6.	Understand the importance of using questionnaires and obtaining good data.		
7.	Learn how to use a spreadsheet application to input the data.		
8.	Learn how to sift information using a spreadsheet application.		
9.	Learn the difference between knowledge and wisdom.		
10.	Understand the importance of data manipulation.		
11.	Learn how to use data handling with a spreadsheet.		
12.	Learn how to process data with a spreadsheet.		
13.	Present data using different methods.		
14.	Understand the importance of using your own content when writing reports.		

# Glossary

## A

- accessory** a device added to a computer that performs an additional feature, but is not required
- active window** the currently selected window
- antivirus program** a software program designed to protect your computer against viruses
- application (app)** a type of computer software designed to perform specific tasks or a group of coordinated functions, or activities for the benefit of the user
- application software** computer software designed to perform a group of coordinated functions, tasks, or activities for the benefit of the user
- archive** an archive file is made up of one or more files that are compressed
- artificial intelligence (AI)** the ability of a digital computer or computer-controlled robot to perform tasks commonly associated with intelligent beings
- authentication** a process of identifying people to make sure that they are who they say they are

## B

- barcode** an optical, machine-readable, representation of data
- biometric** the technical term for body measurements and calculations
- bit** a single unit of information that can have the value of 0 or 1
- bluetooth** wireless technology that enables communication between other compatible devices
- bluetooth technology** wireless technology that works with radiowaves instead of wires or cables
- boot** the process where the computer loads the OS into its main memory or RAM and checks that all the components of the computer are in good order
- browse** reading or scanning through pages on the internet, or on your own computer
- browser** a type of software that lets you browse websites or web pages on the Web

## C

- CamCard** an app used to scan, manage, synchronise and exchange business cards
- Central processing unit (CPU)** the part of a computer responsible for processing general instructions

**cloud** a service provided over a network that provides massive, distributed storage and processing power, and can be accessed by any internet-connected device running a web browser

**cloud storage** a service model in which data is maintained, managed, backed up remotely and made available to users over a network

**codec** a device or program that compresses data to enable faster transmission and decompresses received data

**communication channel** a medium through which a message is sent

**communication device** any device that allows a computer to connect to a network and communicate with other computers on the network

**communication platform** a medium through which a message is channelled to an audience

**compress** to make something (a file or files) smaller

**computer-aided design (CAD)** software used by architects, engineers, drafters, artists and others to create precision drawings or technical illustrations

**computing platform** a computing platform or digital platform is a set of hardware or software that enables application programs to run

**container** a set of files that stores information about the digital file

**core** a processing unit that receives instructions and performs calculations or actions based on the instructions

**crowdfunding** online fundraising

**cursor** this is an indicator that shows the current position for user interaction – for example, a cursor will show you the place where text will be inserted in a document

**cursor positioning device** a touchpad or trackpad is a flat surface that can detect finger contact; it is a stationary pointing device that is commonly used on laptop computers

**cyclic** taking place in cycles

## D

**data** facts, figures, or information that is stored in, or used by a computer

**data link** a method used to connect one location to another in telecommunications to transmit and receive digital information

**decompress** restoring a compressed file back to its original form

**default** a pre-selected option adopted by a computer program

**default setting** the pre-existing value of a user-configurable setting that is assigned to a software application, computer program or device

**digital pen** a battery-operated writing instrument that allows users to digitally capture a handwritten note or drawing

**digitise** to convert (pictures or sound) into a digital form that can be processed by a computer

**directory** another name for a folder; file systems use directories to organise files within a storage device

**disk drive** a type of hardware that allows data to be read, written, deleted, or stored on a computer

**domain** the location of a website

**domain name system (DNS)** the phonebook of the internet

**dots per inch (DPI)** used when referring to a printed copy to measure the number of individual dots placed in a line within the span of one inch (2.5 cm)

**downloading** when your computer or smart device receives a file or data from the internet; to receive data from a remote system, typically a server such as a web server, an FTP server, an email server, or other similar systems

**dynamic IP address** dynamic IP addresses are not permanent; it is assigned to a node until it is connected to the network; therefore, the same node may have a different IP address every time it reconnects with the network

## E

**embedded device** a device that contains a special-purpose computing system

**emoji** an electronic pictograph (picture)

**encode** to change something into a programming code

**ethernet cable** a standard network cable

## F

**file extension** the suffix (letters) at the end of a file name that indicates what type of file it is

**file path** a path that defines the location of a file or folder in a computer's file system

**flash disc** a memory chip used for storage and transferring data, and keeps its data even if there is a break in the power supply

## G

**gigahertz (GHz)** measuring unit to measure computer-processing speed

**graphical interface element** elements used by the GUI to make it easier to interact with a computer, for example checkboxes, buttons, drop lists, icons, menu bars, etc.

**graphical user interface (GUI)** an interface through which a user interacts with electronic devices, such as computers, hand-held devices and other appliances

**graphics interchange format (GIF)** a compressed image file format

## H

**hard disk drive (HDD)** non-volatile memory hardware device that permanently stores and retrieves data from a computer

**hard drive (HD)** non-volatile memory hardware device that permanently stores and retrieves data from a computer

**hardware** refers to all the parts or components of a computer that can be installed inside, or connected to the outside of a computer

**hierarchical tree** a way in which data is organised into a tree-like structure

**home area network (HAN)** a network within a user's home that typically consists of a router and a modem

**hotkey** a keyboard shortcut used to perform a menu function or other common computer functions

**hyperlink** an icon, graphic, or text in a document that links to another file or object

**hypertext mark-up language (HTML)** a type of coding language used on web pages to display text, images and audiovisuals

**hypertext transfer protocol (HTTP)** a set of standards that allow users of the WWW to exchange information found on web pages

## I

**icon** a picture that shows a file, folder or a program

**information and communications technology (ICT)** information and communications technology is a field of study related to computers and communication networks

**interactive** software or hardware whose behaviour changes in response to interaction with a human

**internet protocol (IP)** the main protocol for communication on the internet

**internet service provider (ISP)** a company that provides internet access to its subscribers

## K

**keyboarding** refers to a set of skills required to operate a keyboard smoothly while typing; including being able to understand the computer keyboard layout and its functions

**keylogger** a software program that is used to monitor and log each key a user types on a computer keyboard

## L

**local area network (LAN)** a network used in a small area and in close proximity to each other to share resources and information

**locked documents** documents with content that is difficult to change, or modify once it has been created

**log-on screen** the screen that allows authorised users access to the computer

## M

**Mac** the Macintosh is a family of PCs designed, manufactured and sold by Apple Inc.

**malware** malicious software that is designed to change your settings, delete software, cause errors, watch browsing habits, or open computer to attacks

**memory card** a type of storage medium

**menu** a list of options or commands that the user can select to execute the proper app function

**Microsoft Wordpad** a free rich-text editor from Microsoft

**modem** a hardware device that connects a computer or router to a broadband network

## N

**navigation button** a set of images or icons that serve as a control point to link the user to sections on a website

**netiquette** unwritten rules on how to use the internet

**network adapter** a piece of hardware that can be added to a computer, allowing it to connect to a network

**network administrator** someone responsible for the maintenance and operation of a network or server

**network client** a piece of computer hardware or software that accesses a service made available by a server

**network server** a computer program or device used to manage network resources

**node** any active, physical, electronic device attached to a network

**non-volatile** refers to a computer's memory that will keep data even if there is a break in the power supply

**notification tray** contains miniature icons for easy access to system functions, such as antivirus settings, printer, modem, sound volume, battery status and more

## O

**online** refers to when a user, computer or device is connected to the internet

**open-source software** a software source code that is freely distributed

**optional** left to one's choice; not required or mandatory

## P

**password** a basic security mechanism that consists of a secret phrase created using alphabetic (abc), numeric (123), alphanumeric (a14b) and symbolic characters (\$%\*), or a combination thereof

**personal area network (PAN)** a local network designed to transmit data between PC devices and telephones

**pixel** a tiny dot of colour on a monitor

**plagiarism** taking someone else's work or ideas and passing them on as your own

**platform** the overall standard of a computer's hardware or software

**plug-and-play (PNP) device** a device that has the ability to detect and configure hardware automatically without requiring the user to physically configure the hardware with jumpers or dip switches

**port** a point of connection between a computer and peripheral devices, such as a mouse, keyboard, speakers, printer, monitor, flash drives and so on

**prompts** refers to text or symbols used to represent the system's readiness to perform the next command

**proprietary** relates to an owner or ownership

**protocol** a specific set of rules and instructions that allows computers to communicate with each other

**prototype** a first or preliminary version of a device from which other forms are developed

## R

**Random Access Memory (RAM)** a very fast storage device that can only store a small amount of information at a time

**read-only memory (ROM)** a storage medium used with computers and other electronic devices

**rich-text format (RTF)** a file format standardised by Microsoft for creating formatted text files

**root directory** the directory at the highest level of a hierarchy

## S

**search engine** a software program used to search for keywords on the internet to find documents or the information that was searched

**shareware** software that allows a user to try all, or part of the program for free before buying it

**shortcut** an alternative way to do something that is shorter than the one usually taken

**simple mail transfer protocol (SMTP)** an internet standard for sending and receiving email messages

**site licence** a software licence that allows a user to install a software package in several computers at the same time

**SMTP server** an SMTP server is the machine that takes care of the whole email delivery process

**software** the set of instructions that a computer uses to complete any task

**solid-state drive (SSD)** a storage medium that uses non-volatile memory as a means of holding and accessing data

**spam** describes junk email on the internet

**subscriber identity module (SIM)** it consists of a small chip that is used in cell phones and other mobile devices to store subscriber information

**surround sound** a system of stereophony involving three or more speakers surrounding the listener so as to give a more realistic effect

**swiftkey** a keyboard application that uses various AI technologies that enable it to predict the next word the user intends to type

**switch** a hardware device that filters and forwards network packets

## T

**taskbar** the bar at the bottom of the screen that allows you to locate and launch programs through the *Start* button, or view any program that is currently open

**taxonomy** the science of naming things; in this case, email addresses

**tiles** a new feature consisting of icons on the Windows *START* screen introduced by Microsoft

**touch screen** a computer display screen that is sensitive to pressure; a user interacts with the computer by touching pictures or words on the screen

**touch typing** typing without looking at the keys

**Trojan horse** a program that appears to be safe, but is performing tasks, such as giving access to your computer or sending personal information to other computers

## U

**ultra-portable** very slim, lightweight and easy to carry around

**uniform resource locator (URL)** a standard naming convention for addressing documents that are accessible over the internet

**universal serial bus (USB)** the most common type of computer port used in today's computers

**uploading** when your computer or smart device sends a file or data to somewhere on the internet

**username** a word, phrase, number or combination of characters that uniquely identify a user on any computing device, or related service that requires user authentication

## V

**virulent** hostile or harmful

**virus** a program designed to cause damage, steal personal information, modify data, send emails, display messages, or a combination of these

**volatile memory** computer storage that only maintains its data while the device is powered

## W

**web** refers to the world wide web (WWW), which is a graphical interface for the internet

**web browser** a software program to present and explore content on the WWW

**web server** a computer or collection of computers used to deliver web pages and other content to multiple users

**webmail** a service provided by companies and an ISP to enable you to access your email over an internet page instead of an email client

**web page** a document commonly written in HTML that is accessible through the internet, or other network, using an internet browser

**website** a collection of web pages

**wide area network (WAN)** a collection of computers and network resources connected via a network over a geographic area

**Wi-Fi** a technology that uses radiowaves to provide network connectivity; established using a wireless adapter to create hotspots – areas in the vicinity of a wireless router that are connected to the network and allow users to access internet services

**Wi-Fi hotspot** a location that enables users to connect to a network or the internet with their wireless adapters

**window** an area on the screen that displays information for a specific program

**wireless** telecommunications in which electromagnetic waves (rather than some form of wire) carry the signal over part, or all of the communication path

**wireless access point** a wireless receiver that enables a user to connect wirelessly to a network or the internet

**wireless local area network (WLAN)** a type of local network that uses radiowaves to transmit data wireless technology a technology that uses radiowaves to send and receive data